



Institutional Catalog

Revision:

January - December 2022
Certification number 2021-040

WELCOME MESSAGE

Greetings!

Allow me the pleasure to introduce myself as the President of the Board of Directors of the Universidad Internacional Iberoamericana (UNINI) and present the University to you.

The University is the first in Puerto Rico to be completely online. We offer 17 post graduate programs as a variety of Doctorates, Masters and Certifications.


UNINI's mission is to offer a quality service to the people of Puerto Rico and the rest of the world, with students from 22 countries currently enrolled.

Our main objective is for no one to be denied the possibility of progressing academically due to mobility and economic reasons. Because of this, our online modality counts with a Virtual Campus designed with great care by a group of technical professionals that is versatile and easy to use. We also provide students with the print version of the entire material as found in the Virtual Campus.

We have the support and help of a great professional team, in the academic as well as in the administrative and technical areas. The methodologies of our programs is based on an entirely cooperative and constructive approach.

You may experience all of this for yourself by visiting UNINI.

WELCOME!



Dr. Jesús Arzamendi

INDEX

•• INSTITUTIONAL CATALOG January - December 2022

WELCOME MESSAGE

INTRODUCTION	1
UNIB AT THE SERVICE OF PUERTO RICO	2
ABOUT US	3
AUTHORIZATION OF UNIB	3
MISSION	3
VISION	3
INSTITUTIONAL OBJECTIVES	3
MAIN UNIVERSITY OFFICIALS	5
ACADEMIC DEPARTMENTS	5
OTHER DEPARTMENTS	6
CONTACT INFORMATION	6
FACULTY AVAILABILITY	6
ONLINE COMMUNICATION PLATFORMS	6
ACADEMIC CALENDAR	7
Masters	7
Doctorates	8
ADMINISTRATORS AND LEGAL CONTROL	9
I. Governing Body Positions	9
I.1. Governing Body Organizational Chart	9
I.2. Description of Governing Body Positions	9
I.2.1. Board of Directors	9
I.2.2. Rector	10
I.2.3. Vicerector of International Student Affairs and International Relations	10
I.2.4. Academic Dean	10
I.2.5. Dean of Administration and Finances	10
I.2.6. Dean of Student Affairs	11

I.2.7. Technology Director	11
I.2.8. Head of Virtual Campus	11
I.2.9. Registrar	11
I.2.10. Admissions Officers	11
I.2.11. Department Director	11
I.2.12. Professional Counselor	12
I.2.13. Librarian	12
II. Staff Members	12
II.1. Essential Data on the Staff	12
III. Administrative, Economic and Academic Governing Bodies	14
III.1. Board of Directors	15
III.2. Executive Committee	15
III.3. Academic Senate - Faculty	16
III.4. The Planning, Management and Academic and Administrative Development Committee	16
III.5. Academic Board	17
III.5.1. About the Departments	17
IV. Advisory Council	18
PHYSICAL DESCRIPTION OF THE MAIN STRUCTURES WHERE THE INSTITUTION CARRIES OUT ITS SERVICES	19
PHYSICAL INFRASTRUCTURE	19
DESCRIPTION OF ADMINISTRATIVE AND ACADEMIC FOLLOW-UP SERVICES THAT GUARANTEE QUALITY SERVICE TO STUDENTS AND APPLICANTS	20
ADMINISTRATIVE SERVICES	20
ACADEMIC FOLLOW-UP	20
ACADEMIC PROGRAMS	21
ACADEMIC OFFERINGS AND ITS COMPETENCES	21
Academic Offering Credits and Hours	22
Curriculums	29
PROGRAMS OUTCOMES	84
Department of Language and Communication Science	84
Department Department of Innovation, Business and New Technologies	91
Department of Projects	93
ADMISSIONS REQUIREMENTS	99
ADMISSION POLICY	99
DOCUMENTS TO SUBMIT	99
ADMISSION REQUIREMENTS BY PROGRAM	100
TECHNOLOGICAL REQUIREMENTS	103

Necessary technical skills and knowledge to successfully access and complete your studies	103
Description of the necessary technical and programming equipment for the distance subject	103
ADMISSION TO THE UNIVERSITY	104
PROCESS REVIEW	104
ENROLLMENT AGREEMENT	104
CREDIT ACCEPTANCE AND TRANSFER	105
ACCEPTANCE OF CREDIT TRANSFER STATEMENT	105
FINANCIAL INFORMATION	106
COSTS AND COST POLICIES	106
CANCELLATION AND REFUND POLICY	107
REIMBURSEMENT POLICY	107
FINANCIAL AID	108
SCHOLARSHIP	108
Scholarship Application	108
ON ACADEMIC LIFE	108
HOUR-CREDIT POLICIES OF THE INSTITUTION	111
ACADEMIC GRADING POLICIES	112
GRADING SYSTEM	113
SUBJECT RETAKE	113
TEMPORARY LEAVE OF STUDIES	114
GRADUATION REQUIREMENTS	114
SUPERVISED EXAMS (PROCTORING)	115
Online Evaluation Systems	115
Verification Procedure for Student Identification	115
STUDENT SERVICES	117
REGISTRAR SERVICES	117
COUNSELING PROGRAM DESCRIPTION	118
Counseling Services	118
Reasonable accommodation	118
TECHNICAL SUPPORT	118
LIBRARY SERVICES	119
About the Library	119
UNIB Library Philosophy	119
Objectives	120

Librarian	120
Basic Library Areas and Services	121
INSTITUTIONAL REGULATIONS	124
THE STANDARD OF SATISFACTORY ACADEMIC PROGRESS	124
STANDARD FOR COMPLETING THE DEGREE	125
STANDARD FOR ISSUING POSTHUMOUS DIPLOMAS	125
STANDARDS OF BEHAVIOR	126
STANDARDS OF ONLINE PERFORMANCE	126
STANDARD ON CLASS ATTENDANCE AND INTERACTION	126
STANDARD RELATED TO ACADEMIC HONESTY	126
STANDARD FOR ACADEMIC CONTROL AND DISCIPLINE	127
STANDARDS OF BEHAVIOR	129
MUTUAL RIGHTS AND OBLIGATIONS OF THE INSTITUTION AND STUDENTS	130
RIGHTS AND OBLIGATIONS OF THE INSTITUTION WITH STUDENTS	130
RIGHTS AND OBLIGATIONS OF STUDENTS WITH THE INSTITUTION	131
RIGHTS AND OBLIGATIONS OF THE FACULTY WITH THE STUDENTS	132
POLICIES	132
PRIVACY POLICY TO PROTECT THE INFORMATION CONTAINED IN THE ACADEMIC RECORDS (FERPA LAW)	132
PROCEDURES AND MEASURES TO LIMIT ACCESS TO STUDENT ACADEMIC RECORDS	132
PROTECTION MEASURES AND CONFIDENTIALITY OF CREDIT OR CREDIT	133
PROCEDURES AND MEASURES TO PROTECT ACADEMIC RECORDS FROM FIRE, FLOOD AND OTHER DISASTERS	133
POLICY ON UNAUTHORIZED SERVER ACCESS	133
USE AND DIVULGENCE OF THE SOCIAL SECURITY NUMBER	134
PLAN TO FACILITATE ACCESS FOR STUDENTS WITH DISABILITIES TO THE FACILITY AND INSTITUTIONAL ACTIVITIES (ADA LAW)	134
RIGHTS OF MILITARY STUDENTS	135
POLICY FOR MAINTAINING THE ACADEMIC OFFERING AND GUARANTEE OF STUDIES CONTINUITY IN THE CASE OF INSTITUTIONAL CLOSURE (TEACH-OUT)	135
Policy on Maintaining an Academic Offering	135
Guarantee of continuity of studies in case of institutional closure	135
POLICY ON BULLYING AND CYBERBULLYING	136
A. Objective	136
B. Justification	136
C. Definition and description of harassment and school and cyberbullying	136

D. Expectations and Institutional Policy	137
E. Responsibilities of the University Community members	137
F. Prevention Strategies	138
G. Procedure for disclosure of the protocol	139
H. Procedure for case documentation, confidentiality and record keeping	139
I. Case Complaint Procedure	139
J. Complaint Investigation Strategies	140
K. Intervention strategies and sanction for cases	140
L. Follow-Up Strategies	142
M. Referral guidelines for health professionals	142
ABOUT THE ETHICAL AND LEGAL USE OF INFORMATION TECHNOLOGIES	143
FACULTY	144
RECORD OF DEPARTMENT DIRECTORS	144
RECORD OF FACULTY MEMBERS	145
GLOSSARY	204

INSTITUTIONAL CATALOG

JANUARY - DECEMBER 2022

INTRODUCTION

The **Universidad Internacional Iberoamericana (UNIB)** is an institution of higher postgraduate education which goals and guidance guarantees equal study opportunities for everyone with a continuous enrichment of the study programs through two methods:

- improvement and adaptation of the study methodologies based on the type of program and the competencies to be obtained,
- development and update of the study programs appropriate for the social demands.

UNIB promotes a model in which the student is the axis of the training with a clear adequacy of theoretical study to work applied with methodologies linking theory with practice. In methodological terms, mechanisms which use the new technologies to enrich training and to provide a contribution to research in distance education are used. This emerges as a commitment to quality.

Nowadays, this enables us to offer academic, administrative and technological support and management that facilitates access to distance study in all its components:

- economic ease according to each person,
- technological infrastructure which enables access to educational systems from any point in the world,
- monitoring, security and confidentiality of people's information,
- continuous research in distance education and the modes related for offering a study program in accordance with its objectives,
- physical infrastructure which enables supporting students in person, and
- continuous academic and administrative support to facilitate the student's academic life.

In terms of academic work, UNIB is characterized by an institutional commitment and an academic experience in distance learning. An academic management approach to face to an instructional design subject to continuous update and improvement.

- A support system for students in the use of ICTs as an end and as a means of professional and personal implementation to face the new demands of globalization.
- The management of teaching resources and recognized training methodologies and processes to improve these resources and methodologies, and procedures related to quality services and equipment suitable for distance education.

This spirit will be more firmly embodied in:

- the commitment to complete the study programs offered by the Universidad Internacional Iberoamericana in case of closure by allowing active students to finish their studies.

In this sense, the Universidad Internacional Iberoamericana included, in its constitution project, services that have ensured and still ensure an online 24x7x365 service to the student, together with procedures, models and methods of distance learning and consolidated university management that provide the basis of operation of the University itself. In this way, the Universidad Internacional Iberoamericana is for Puerto Rico a medium that projects its formative vocation and its educational model to society in a serious, rigorous and effective manner as of the first day of its operation.

UNIB AT THE SERVICE OF PUERTO RICO

Before Puerto Rico, the Universidad Internacional Iberoamericana is formed as a mean to:

- To seek the complete education of the student in the desired training and to prepare them as a global citizen in the use and through the Information and Communication Technologies and the Internet.
- Promote and disseminate the values of the people of Puerto Rico through the means provided by new technologies.
- To develop an academy and research in distance studies with an international scope through the integration with culture, society and business, expanding all technological, social and business relationship transfers that support the country's development.

The presence of the Universidad Internacional Iberoamericana in Puerto Rico is already seen as a contribution to the country through the trust shown by entities of the country with their support to the university project, and support in providing resources and infrastructure.

The Universidad Internacional Iberoamericana has taken up the mission of being an international reference point for distance education.

The Universidad Internacional Iberoamericana will contribute human and knowledge capital in a responsible manner and will transfer it to society through accessible study programs and with a direct impact on the country's economy.

ABOUT US

Postal Address: PO Box 3385 Arecibo, PR 00613-3385

Physical Address: Bo. Arenalejos Sector Palache, Carr. 658, Km 1.3 Arecibo, PR. 00612

Telephone Numbers: 787-878-2126 /787-878-2123

<http://www.unib.org>

AUTHORIZATION OF UNIB

The Universidad Internacional Iberoamericana is authorized by the Board of Postsecondary Institutions (Junta de Instituciones Postsecundarias - JIP) <http://www.ce.pr.gov> under Certification number 2021-040.

The entirety of this catalog's documentation is made public and available to the Community through the digital means of the University, and may be requested to the Dean of Administration and Finances.

MISSION

The Universidad Internacional Iberoamericana is an institution of higher education committed to safeguarding equal opportunities and respect for diversity. It educates competent, autonomous professionals with the purpose of contributing to social, cultural and economic development in an intercultural context under the principles of education for all and the universalization of knowledge, through a quality distance model.

VISION

To be a University of excellence, sustainable, adapted to the characteristics of its students, recognized for its academic programs with an applied and practical approach. It commits its actions to the service of society in a borderless framework, expanding opportunities through networking, internationalization, diversity and interculturality.

INSTITUTIONAL OBJECTIVES

General Objective 1:

- To consolidate an international educational community, based on respect, diversity of origin within a setting of multicultural experiences in favor of the integrity and well-being of its participants as well as the environment.

Goal 01:

- Implement institutional policies for the creation of linkages, knowledge transfer, creation, and well-being of people.

- Broaden the current student orientation and support system that favors persistence in the academic program.
- Improve elements of institutional management, enabling effective communication towards a prompt resolution and attention to the members of the community.

General Objective 2:

- Provide high quality academic programs aimed at people without distinction of geographic, cultural and socioeconomic origin, through a competency-based training model, with a cooperative and collaborative methodology.

Goal 02:

- Design high quality curricula, aligned with the institutional, professional, academic and scientific context, with a flexible teaching-learning model, adjusted to the student's profile, in response to the changes present in society.
- Establish educational methodologies adapted to the context, the student profile and the distance learning modality.
- Develop educational technologies that favor the quality of the teaching-learning processes consistent with the study methodology.
- Implement permanent self-evaluation processes for continuous improvement and high quality.

General Objective 3:

- Foster the creation and transfer of knowledge by promoting research projects and national and international collaboration networks.

Goal 03:

- Broaden strategic links for national and foreign collaboration with educational institutions, business and social contribution entities.
- Establish actions according to strategic axes in favor of exchange, inter-institutional mobility of faculty, administrative personnel and students.
- Promote collaborative and participative work of an intra- and inter-university nature aimed at the creation and transfer of knowledge.

General Objective 4:

- Consolidate an efficient and organized institutional management model based on the fulfillment of the stated mission and objectives.

Goal 04:

- Implement an internal quality assurance system oriented to self-assessment and continuous improvement in accordance with international standards.

- Organize actions of governance, administration and finance planned towards the efficiency and sustainability of the University.
- Consolidate a management model that facilitates access to the programs offered to students according to their social and cultural context.
- Broaden current strategies to achieve growth in enrollment and academic offerings in accordance with academic, professional and contextual requirements.

General Objective 5:

- Strengthen the institutional educational project, in accordance with the model that aims to develop a flexible teaching-learning curricular framework, articulated through the use of advanced educational technologies that favor the quality of the processes.

Goal 05:

- Coordinate academic-administrative actions to optimize the institution's strategic decision making based on evidence, from the application of data mining and educational process mining techniques.
- Promote networks, action frameworks, research and practical application projects, based on the diversity of experiences and contexts from which students and faculty come from.
- Strengthen the digital environment, according to the new challenges of education and society, providing resources according to the training requirements of teachers and students.

MAIN UNIVERSITY OFFICIALS

- Dr. Jesús Arzamendi Sáez de Ibarra, President.
- Dr. Ana Rodríguez, Rector.
- Mrs. Gigliola Insuasty, Vice-rector of International Student Affairs and International Relations.
- Dr. Carolina Rodríguez, Academic Dean.
- Mrs. Lillian Díaz Figueroa, Dean of Student Affairs.
- Prof. Carol Morales Miranda, Dean of Administration and Finances.

ACADEMIC DEPARTMENTS

- Dr. Eduardo García Villena - Department of Environment and Sustainability.
- Dr. Manuel Masías, Innovation, Business and New Technologies Department Director.
- Dr. Silvia Pueyo, Language, Education and Communication Sciences Department Director.
- Dr. Irma Domínguez, Director of the Health Sciences Department.
- Dr. Roberto Álvarez, Director of the Projects Department.
- Dr. Carolina Rodríguez, Academic Dean.

OTHER DEPARTMENTS

- Dr. Kilian Tutusaus, Responsible for the Virtual Campus.
- Dr. Mayra González, Professional Counselor.
- Mr. Ramón Güilamo, Registrar.
- Ms. Yara L. Cruz, Librarian.

CONTACT INFORMATION

- **Office Hours:** Monday through Friday, 8:00am - 5:00pm
Bo. Arenalejos, Sector Palache, Carr. 658, Km 1.3 Arecibo, PR. 00612
- **Technical Support for Students:** 24-7 through the Virtual Campus
Access button available in the student's PANAL, top menu, "Contact" button
- **Faculty Availability:** 24-7 through the Virtual Campus
Access button available in the Virtual Campus, within the Faculty icon found within each subject area.

FACULTY AVAILABILITY

Though the faculty members are available through the Virtual Campus 24 hours 7 days a week, there are periods during the year where they have an academic recess. The professor will notify the students about the recess or vacation period through the Virtual Campus and email.

ONLINE COMMUNICATION PLATFORMS

The PANAL is the communication channel between the student and UNIB. The following tools are found within it:

Profile: Refers to student's personal and contact information. It is the student's responsibility to maintain his/her information updated, which can be individually managed by clicking "Edit profile".

- **Admissions Department.** Here the student will consult/request:
 - Request information about new programs, presentations or conferences.
- **Deanship of Student Affairs.** Here the student will consult/request:
 - Certificates and titles.
 - Withdrawal (delay of studies) and reincorporation.
 - Extensions (extension of academic time).
 - Printed material shipment (textbooks).
- **Technological Support Department.** Here the student will consult/request:
 - Errors accessing the virtual campus.
 - Suggestions regarding the campus and PANAL.

- **Deanship of Administration and Finances.** Here the student will consult/request:
 - Changes or modifications in financial information (Credit or debit card details, bank account numbers).
 - Request of invoice/receipt.

Likewise, UNIB is currently searching to better position itself on the web and social networks that promotes communication with/between students and alumni.

The current platforms may be found at:

Webpage: <https://www.unib.org/> [available in Spanish | Portuguese | English]

Blog: <https://blogs.unib.org/> [available in Spanish | Portuguese]

Facebook: <https://www.facebook.com/UNIBpr>

Twitter: <https://twitter.com/unibpr>

Linked-In: <https://www.linkedin.com/school/universidad-internacional-iberoamericana/>

ACADEMIC CALENDAR

Masters

Time	Action
February of each year.	Beginning of the modules for Master in Teaching Spanish as a Foreign Language, Master in Teaching English as a Foreign Language, Master in Education With a Specialty in Higher Education, Master in Education With a Specialty in Teacher's Training and Master in Education With a Specialty in ICTs in Education.
March of each year.	Beginning of the modules for the Master in Project Design, Administration and Management.
June of each year.	Beginning of the modules for Master in Teaching Spanish as a Foreign Language, Master in Teaching English as a Foreign Language, Master in Education With a Specialty in Higher Education, Master in Education With a Specialty in Teacher's Training and Master in Education With a Specialty in ICTs in Education.
September of each year.	Beginning of the modules for the Master in Project Design, Administration and Management.
October of each year.	Beginning of the modules for Master in Teaching Spanish as a Foreign Language, Master in Teaching English as a Foreign Language, Master in Education With a Specialty in Higher Education, Master in Education With a Specialty in Teacher's Training and Master in Education With a Specialty in ICTs in Education.
Upon completion of 66% of the master's program.	The student may begin their master's thesis. The Master's Thesis may not be defended before completing and passing all the subjects.

Doctorates

Doctorate in Projects with a Specialty in Research

Duration	Action	
5 months	Phase I Module I: General courses and doctoral worksheet	The module has 5 subjects which may be started at any time; must have passed the “Collaborative Work in Virtual Environments” subject and two others to continue onto the next module.
8 months	Phase II Module II: Modular courses	This module is offered four times in a year. The module is begun every three months: February, May, August and November
12 months	Phase III TI1 and TI2 Doctoral Thesis Proposal	This phase begins at the start of each month. Two months for TI1 and two months for TI2. (They are carried out with a tutor) After passing said subjects, the Doctoral Thesis Proposal can be started (a thesis director is assigned within two months) with 8 months of planning.
13 months	Phase IV Thesis development (Progress 1 and Progress 2) and the scientific article	Progress 1 includes chapters 2, 3 and 4 of the thesis and Progress 2 includes chapters 1, 5 and 6 of the thesis. A scientific article must also be approved for publication in a prestigious journal that is, at least, indexed and registered in two databases.
3 months	Final Report and Dissertation	When the report is delivered, an outside expert has one month and a half to approve the article, with a minimum of two months due to observations, and another month to print the thesis, deliver it and assign a board for its defense.

Doctorate in Education with a Specialty in Research

Duration	Action	
5 months	Phase I Doctoral Worksheet	May be started at any time. It consists of the “Methodology of Scientific Research” subject and a research seminar to prepare the doctoral worksheet.
12 months	Phase II Teaching	Only study those subjects that have been selected in the doctoral worksheet should be studied. The subject closest to the date in which the teaching phase commences should be the first to be studied for the academic period. The subjects’ academic periods begin on the first work day of the month. The student can only begin the subject’s tutoring until the tenth of each month.
12 months	Phase III TI1 and TI2 Doctoral Thesis Proposal	This phase begins at each month. Two months for TI1 and two months for TI2. After passing the subjects, the Doctoral Thesis Proposal begins, (approx. 8 month duration)
13 months	Phase IV Thesis development (Progress 1 and 2) Scientific article	Progress 1 includes chapters 2, 3 and 4 of the thesis and Progress 2 includes chapters 1, 5 and 6 of the thesis. A scientific article must also be approved for publication in a prestigious journal that is, at least, indexed and registered in two databases.
3 months	Final Report and Dissertation	When the report is delivered, an outside expert has one month and a half to approve the article, with a minimum of two months due to observations, and another month to print the thesis, deliver it and assign a board for its defense.

ADMINISTRATORS AND LEGAL CONTROL

I. GOVERNING BODY POSITIONS

I.1. Governing Body Organizational Chart

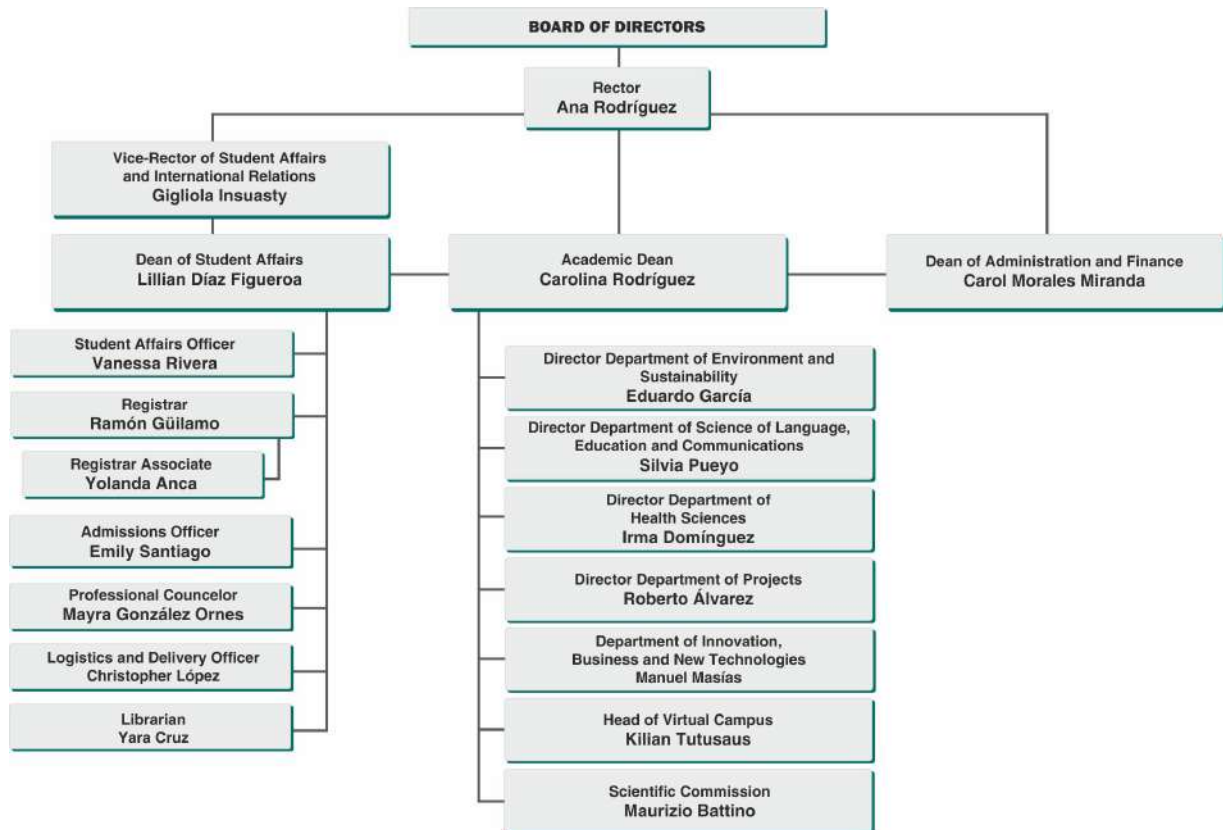


Figura 1: Organizational Chart.

I.2. Description of Governing Body Positions

I.2.1. Board of Directors

- It is the top decision-making body of the University, responsible for establishing institutional policies on the basis of strategic guidelines laid down by the University in response to society. It is regulated through the sections of this document and by the other regulations that are appropriate for its operation.
- It is the board that protects under the law and the spirit of the University the policies and decisions made, and can revise them when the nature, vision and principles of the University are affected.

I.2.2. Rector

- The Rector is the highest executive and administrative authority of the University and is the legal representative. They are responsible for the general management and administration of the University, with administrative and academic institutional responsibility. Is ultimately responsible for the University management in all its orders and levels in function with the philosophy, mission, and vision of the University.

I.2.3. Vicerector of International Student Affairs and International Relations

- Responsible for planning, developing and evaluating the areas concerning Admissions, Registration, Student Affairs, Logistics and Shipping.
- In charge of being in contact with those universities that have agreements with UNIB.
- Will promote the establishment of agreements as appropriate for the improvement of the University.

I.2.4. Academic Dean

- Leads the administrative unit: Academic Deanship.
- They are the executive authority working under the direct authority of the Rector.
- Leads the faculty of the different educational programs and their development.
- Is charged with the publishing activities of the University.
- Leads and manages the academic offerings in distance education environment.
- Leads the supervision of the professors, curriculum design and student performance expectations.
- Is responsible for promoting and/or managing the academic policies and strategies that will generate the research spirit among professionals, relating their education with innovative developments, and analysis, adaptation, and incorporation into the practice of the progress of a disciplinary field or of specific aspects of an area of knowledge through the use of information technologies and communication.
- Promotes and/or manages business-university educational transfer through the development of the departments in academic, scientific and research terms through programs of study and through the promotion of science and technology on related topics.
- Their concern focuses at all times on increasing the academic excellence of distance education.
- Must surveil and protect the academic record of the university.
- Is responsible for the strict confidentiality in the processes and management of the university documents.

I.2.5. Dean of Administration and Finances

- Leads the administrative unit: Deanship of Administration and Finances.
- Is are the executive authority with administrative and financial responsibilities working under the direct authority of the Rector.

- This department is responsible for the proper use and operation of the assets, administrative, financial and material resources of the University.
- Must monitor and protect the administrative, financial, material and service records of the University

I.2.6. Dean of Student Affairs

- Leads the administrative unit: Deanship of Student Affairs.
- Is the executive authority with the responsibility of student services who exercises their role under the direct authority of the Rector.
- This department is responsible for making good use of student services to increase their level of quality and excellence and provide resources for this same purpose.
- Must monitor and protect the University services.

I.2.7. Technology Director

- The technology Director guides all activities related to the design, use and diffusion of technologies in UNIB as part of its business model and as part of the model of society's relationship.

I.2.8. Head of Virtual Campus

- Position responsible for maintaining the entire virtual campus computer system and the associated university and institutional management systems.

I.2.9. Registrar

- Is responsible for issuing academic degrees and preparing Credit Transcripts, Notarial Certificates, Certifications, Study Programs and Study Plans.
- They are responsible for verifying and processing diplomas for the different University processes.
- Ensures strict confidentiality in the processes, transactions and document management in the university.

I.2.10. Admissions Officers

- Are responsible for carrying out the appropriate steps for student recruitment in the areas of interest.

I.2.11. Department Director

- These are the persons responsible for managing an academic department, projecting its research and development lines and coordinating the program managers' resources, efforts and obligations.

I.2.12. Professional Counselor

- Provide support and guidance to any student presenting any kind of worry that may interfere with their performance.
- Evaluate the student's needs and provide alternative actions.
- Carry out emergency referrals following a set protocol.

I.2.13. Librarian

The person responsible for managing the information services.

II. STAFF MEMBERS

II.1. Essential Data on the Staff

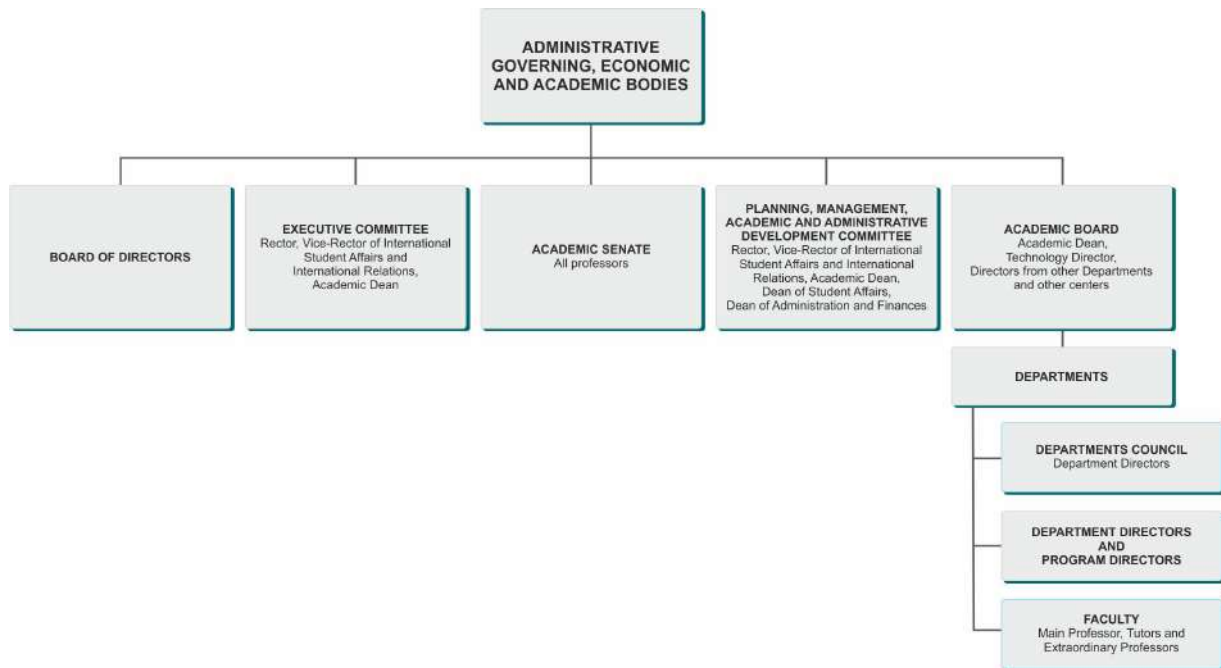
The following is the academic information on the main staff relating to their post, academic degree and the institution where they obtained their degree or diploma.

Staff	Position	Degrees	Institution
Ana Rodríguez Zubiaurre	Rector	Doctorate in Applied Economics	University of Las Palmas de Gran Canaria, Spain (2013).
		Diploma of Advanced Studies Applications to Finances and Insurance, Sectorial Economy, Environment, Infrastructure and Transportation.	University of Las Palmas de Gran Canaria, Spain (2010).
		Degree in Oceanography, Specializing in Coastline Management.	University of Las Palmas de Gran Canaria, Spain (2007).
Gigliola Insuasty	Vicerector of International Student Affairs and International Relations	Organizational Communication and Modern Language Professional	Business Administration School (EAN) (2015).
		Business Administration Professional	Central University, Bogota, Colombia (2000).
Carolina Rodríguez	Academic Dean	Doctorate in Human Motricity	Metropolitan University of Education Sciences. Ñuñoa, Santiago (2019)
		Master in Strategic Management, Administration	European University of the Atlantic. Santander, Spain. (2016)
		Bachelor in Education	Metropolitan University of Education Sciences. Ñuñoa, Santiago. (2005)
Carol Morales Miranda	Dean of Administration and Finances	Master in Business Administration with a specialty in Human Resources.	University of Phoenix in Guaynabo, Puerto Rico (2009).
		Bachelor in Business Administration and Management with a Major in Accounting	University of Puerto Rico, Utuado Campus (2005).
Lillian Díaz Figueroa	Dean of Student Affairs	Master in Business Administration with a specialty in Management.	University of Turabo, Gurabo, Puerto Rico (2010).
		Bachelor in Business Administration with a major in Management	University of Puerto Rico, Ponce Campus (1994).
Kilian Tutusaus Pifarré	Head of Virtual Campus	Doctor in Engineering Projects: Environment, Safety, Quality and Communication	Polytechnic University of Catalonia (UPC), Spain (2016).
		Master in Environmental Engineering	Chemical Institute of Sarrià (IQS), Spain, (2000).

Staff	Position	Degrees	Institution
Eduardo García Villena	Department Director of the Environment and Sustainability	Doctor in Engineering Projects: Environment, Quality, Safety and Communication	Polytechnic University of Catalonia. Spain (2011).
		Master in Environmental Technology and Engineering.	Polytechnic University of Catalonia. Spain (2006).
		Technical-Superior Industrial Engineering with specialization in Energetic Techniques.	Higher Technical School of Industrial Engineers. Polytechnic University of Catalonia. Spain (1996).
Manuel Masías Vergara	Department Director of Innovation, Business and New Technologies	Industrial and Systems Engineering	University of Piura, Peru (2001)
		Master's Degree in Strategic Management in Information Technology and Telecommunications	University of Leon, Spain (2009)
		Doctor in Engineering Projects	Universidad Internacional Iberoamericana (2018)
Silvia Pueyo	Silvia Pueyo, Department Director of the Language, Education and Communication Sciences	Doctorate in Education Sciences	University of Barcelona (2016).
		Master in Linguistics Applied to the Teaching of Spanish as a Foreign Language	University of Jaen and the Universidad Internacional Iberoamericana (2008-2009).
Irma Domínguez	Department Director of Health Sciences	Doctorate in Education	Universidad Internacional Iberoamericana (2021)
		Master in Physical Activity. Sports and Management	Universidad Internacional Iberoamericana (2012)
		Master in Vegetarian Nutrition with a Specialty in Dietetics	University of Santiago de Compostela (2007)
		Degree in Human Nutrition and Dietetics	University of Navarra (2000)
Roberto Álvarez	Department Director of Projects	Doctor in Engineering Projects	Polytechnic University of Catalonia
		Graduate in Strategic Planning	University of Buenos Aires - Argentina.
		Graduate in Investment Project Appraisal for Non-Specialists	University of Buenos Aires - Argentina.
		Specialist in Strategic Design Management	University of Buenos Aires - Argentina - Polytechnic University of Milan (2000).
		Project and Design Management	Faculty of Architecture, Design and Urbanism - Argentina (2000).
		Architecture	University of Buenos Aires - Argentina (1996).
Ramón Güilamo	Registrar	Bachelor in Communications with a specialty in Radio and Television	University of Puerto Rico, Arecibo Campus (2007).
Mayra González	Professional Counselor	Doctorate in Education with a Specialty in Counseling and Guidance	Interamerican University of Puerto Rico, Metro Campus (2016).
		Masters Degree in Counseling and Guidance	Interamerican University of Puerto Rico, Arecibo Campus (2003).
Yara Cruz	Librarian	Master in Information Sciences	University of Puerto Rico, Rio Piedras Campus (2010).
		Bachelor in Political Science	University of Puerto Rico, Rio Piedras Campus (2004).

III. ADMINISTRATIVE, ECONOMIC AND ACADEMIC GOVERNING BODIES

The University, as an institution, has an organizational structure that responds to the existing standards, to its philosophy, mission, vision, objectives, comprised of five governing bodies:



1. Board of Directors.
2. Executive Committee:
 - Rector.
 - Vicerector of International Student Affairs and International Relations
 - Academic Dean.
3. Academic Senate (All professors).
4. Planning, Management and Academic and Administrative Development Committee:
 - Rector.
 - Vicerector of International Student Affairs and International Relations
 - Academic Dean.
 - Dean of Student Affairs.
 - Dean of Administration and Finances.
5. Academic Board:
 - Academic Dean.
 - Technology Director.
 - Directors from other Departments and other centers.

III.1. Board of Directors

Characteristics:

It is the highest institutional decision-making body, with legal control and guidance of the University's internal processes, in function with the philosophy, mission, vision, fines and institutional objectives, with faculties in:

- Develop and approve institutional policies and rules.
- Define the policies for academic, administrative and institutional planning; academic, administrative and financial organization; perspectives and strategies for institutional development.

Composition:

This Board is constituted by a President, Secretary, three members and Rector.

- Dr. Jesús Arzamendi - President.
- Dr. Santos Gracia - Secretary.
- Mrs. Luisa Fernanda Celis - Member.
- Dr. Luis Dzul - Member.
- Dr. Jorge Ayala - Member.
- Dr. Ana Rodríguez Zubiaurre - Rector.

III.2. Executive Committee

Characteristics:

Is responsible for:

- Establishing the general institutional regulations and policies;
- Managing the internal processes of the University;
- Implementing the policies, institutional regulations and guidelines issued by the Board of Directors;
- Lead all the University activities in accordance with the General Private University Regulations, the regulations in force, statutes and regulations particular to the University.
- It has the permanent task of promoting, guiding and directing the fulfillment of the Board decisions and the policies also adopted by the Board of Directors as the top governing body for institutional decisions in addition to any amendments made.

Composition:

This Board is comprised of:

- Rector.

- Vicerector of International Student Affairs and International Relations
- Academic Dean.

III.3. Academic Senate - Faculty

- Advisory Team, consultative and/or proponent to the Rectory for any subject related to the proper functioning of the University, and who points out the improvement and maintenance of its essential pillars
- The Faculty is the set of all professors at the University.
- The senate is the representative body of all of the University's strata at a rate established by its internal regulations and chaired by the Rector and the Academic Dean.
- The staff looks after the fulfillment and development of the University's mission from the spirit of its vision and principles.

III.4. The Planning, Management and Academic and Administrative Development Committee

Characteristics:

It is the committee responsible for:

- Academically managing and developing the University with the aim of ensuring the integration and continuous improvement of teaching, learning and self-learning processes, through teaching tutorials and technological resources.
- Revising frequently the Strategic Plan and the institutional norms and policies.
- Preparing, revising and recommending the budget assignment to the Board Director of University.
- It is also responsible for the management of financial resources, as well as executing the decisions of the Board, in such issues as the academic, scientific and professional management, operation and development.

Composition:

This Board is comprised of:

- Rector.
- Vicerector of International Student Affairs and International Relations
- Academic Dean.
- Dean of Student Affairs.
- Dean of Administration and Finances.

III.5. Academic Board

Characteristics:

- It is the advisory board for the Rector and the Board of Directors of the University, with authority to make proposals to the same.
- This board is present in the academic environment with advisory bodies, through the Council Department and Academic and Research Guidance formed by academics and professionals from the University and people with a professional and academic trajectory.
- Legal Services and Internal Audit are also part of the board as necessary.

Composition:

This Board is comprised of:

- Academic Dean.
- Directors from other Departments and other centers.

III.5.1. About the Departments

The Departments are the units responsible for providing the study programs. The Administrative and Academic Management functions and responsibilities are as follows:

1. **Department Director.** Is the person responsible for managing an academic department, projecting its research and development lines and coordinating the program managers' resources, efforts and obligations. May be a Program Director.
2. **Program Director.** Position responsible for managing the proper execution of an studies program.
3. **Main professor.** Role charged with leading the studies programs and their subjects with excellence and quality, offering studies program capable of competing at the international level, of carrying out research on distance education related with their area of study and participating in program study academic commissions.
4. **Tutor.** Performs the role of a professor that supports, assists and facilitates the student's academic progress in fulfilling their duties and their academic performance within the program and subjects.
5. **Extraordinary professor: visiting, collaborating, or associate professor.** May provide temporary support, and in some cases, assume leadership tasks in determined disciplines or areas.
6. **Department Council.** The Department Council, is comprised of the Department directors. Informs the Rector of cross-departmental issues, of its state and of its solution or resolution of problems affecting the University. It focuses on operational or daily issues related to the proper functioning of the Departments and their programs, as well as to facilitate the transfer of experience and knowledge, and enhance the cooperative and collaborative character and synergies of the University.

Any action by the University will be based on the central points of quality distance learning.

IV. ADVISORY COUNCIL

They verify that the curriculums are up-to-date in accordance with the required competencies in the different programs and with the professional laws that govern the profession's practice, and they emit recommendations that are evaluated by the deans and the rector. They are also involved in the revision of the mission, vision and goals.

The members of the Advisory Council are:

- Ana Saldanha.
- Carlos Díaz Llorca.
- Joaquín Azcue.
- Lázaro Cremades Oliver.
- Elvira Carles Brescolí.
- Joanna Acevedo.
- Carlos J. Bosques Cardona.
- Miguel Pérez Ferra.
- Beatriz Berrios Aguayo.
- Diana Amber Montes.
- Dr. Araceli Alonso.
- Dr. Rubén Pérez.
- Dr. Antonio Bueno.
- Dr. Jesús López-Peláez.
- Dr. Laura García.
- Dr. Luis Francisco EcheGARAY.
- Edgardo Ramírez.
- José Barreiro.
- Irene Salamanca.
- Raúl González.
- Samuel Báez.

PHYSICAL DESCRIPTION OF THE MAIN STRUCTURES WHERE THE INSTITUTION CARRIES OUT ITS SERVICES

PHYSICAL INFRASTRUCTURE

The location of the facilities are as follows: the south part of the building and the main entrance which faces Km 1.3 1.3 on highway 658 in the municipality of Arecibo. On the north side of the building is the boundary at Km 69 of highway 22, Palache sector of the Arenalejos neighborhood in Arecibo. The building has parking space in the front and back with an average total of 3,930.623 meters.



DESCRIPTION OF ADMINISTRATIVE AND ACADEMIC FOLLOW-UP SERVICES THAT GUARANTEE QUALITY SERVICE TO STUDENTS AND APPLICANTS

ADMINISTRATIVE SERVICES

The experience and knowledge acquired by the members of the deanships is transferred to the services offered to students. The emphasis of the university is to achieve quality and excellence services that contribute to student retention and that the student achieves their educational goals and competences

The different areas that offer quality and excellence services are:

Student Affairs Deanship

- Admissions.
- Registrar.
- Student Affairs.
- Professional and Personal Counseling.

Deanship of Administration and Finances

- Economic Assistance.
- Treasury.

Academic Deanship.

- Academic Counseling.
- Library.

ACADEMIC FOLLOW-UP

The University has an online computer system for the academic monitoring of students. This system has risen from acquired experienced and the technology transferred to the University. A computer system has been developed that allows the management of the academic data of a person throughout their academic life, and which the University now possesses.

Access to this information is regulated by profiles, with one of them being the personal and unique profile that each student will have in order to access their records.

ACADEMIC PROGRAMS

ACADEMIC OFFERINGS AND ITS COMPETENCES

The Universidad Internacional Iberoamericana offers the following programs through its various departments:

Department of Language and Communication Science

- Doctorate in Education with a Specialty in Research (DODE).
- Master in Teaching Spanish as a Foreign Language (FPMELE).
- Master in Teaching English as a Foreign Language (FPMTFL).
- Master in Education with a Specialization in Higher Education (FPMME).
- Master in Organization and Management of Educational Centers (FPCOCE).
- Master in Education with a Specialization in Professor Training (FPMMEFP).
- Master in Education with a Specialization in ICT in Education (FPMMETE).

Department of Innovation, Business and New Technologies

- Master in Strategic Management with a Specialty in Management (MDE).
- Master in Strategic Management with a Specialty in Information Technology (MDETI).
- Master in Strategic Management with a Specialty in Telecommunications (MDETEL).

Department of Projects

- Doctorate in Projects with a Specialty in Research (DODP).
- Master in Project Design, Administration and Management (MDGDP).
- Master in Project Design, Administration and Management with a Specialty in Architecture and Urban Planning (MPAU).
- Master in Project Design, Administration and Management with a Specialty in Innovation and Product (MDPIP).

Department of Environment and Sustainability

- Master in Environmental Management and Auditing (MAMGA).

Department of Health Sciences

- Master in Physical Activity: Sports Training and Management (SNMAFEGD).
- Master in Naturopathic Sciences (SNMCN).

Academic Offering Credits and Hours

Department of Language and Communication Science					
Name	Code	Degree Offered	General Competencies	Duration (Months)	Credits
Doctorate in Education with a Specialty in Research	DODE	Doctorate in Education with a Specialty in Research	<ol style="list-style-type: none"> 1. Providing the students with the fundamental concepts and research methodologies used in the field of Education, as well as training them to design, develop and assess, both individually and in a team, research projects in the different lines offered so they can work as the driving force of improvements in educational processes in different levels and settings. 2. To teach in new or unfamiliar environments within broad educational contexts so that the student may apply the knowledge acquired, making judgments, making decisions and solving problems, thus contributing to the different approaches related to educational research. 3. To provide scientific research tools that will allow the student to manage pedagogical projects and conduct research or produce creative work, thus showing mastery of the content in an ethical manner. 	60	75 credits
Master in Teaching Spanish as a Foreign Language	FPMELE	Master in Teaching Spanish as a Foreign Language	<ol style="list-style-type: none"> 1. Offering wide and up-to-date training for Spanish as a Foreign Language teachers in elementary, middle or high school in public and private institutions, and Spanish as a Foreign Language teachers in adult education, as well as graduates in related specialties who have the intention of working as Spanish as a Foreign Language teachers, providing the basis for the development of the academical and professional skills needed for teaching Spanish as a Foreign Language in any of the teaching-learning contexts with fluency, coherence and in an adequate way for the educational context in which they develop their professional activity. 2. Teaching in new or little known settings in wide contexts related to teaching Spanish as a Foreign Language so the student can apply the acquired knowledge, formulating opinions, making decisions and solving problems, reflecting on their own education and professional development. 3. Providing the scientific research tools that allow the student to use the methodological processes for pedagogical research of the language and applied linguistics applied to the Spanish language training. 	24	66 credits

Department of Language and Communication Science					
Name	Code	Degree Offered	General Competencies	Duration (Months)	Credits
Master in Teaching English as a Foreign Language	FPMFL	Master in Teaching English as a Foreign Language	<ol style="list-style-type: none"> 1. Leading, in an informed and well-supported manner, the situations and professional needs related to the working environment, encouraging autonomy without losing sight on elements of constant, but flexible, interaction adjusted to the specific necessities of the master in professional development; facilitating training for English masters in elementary, middle and high school in public and private institutions; English as a Foreign Language masters in adult education, and graduates. 2. Teaching in new or little known settings in wide contexts related to teaching English FL so the student can apply the acquired knowledge, formulating opinions, making decisions and solving problems, reflecting on their own education and professional development. 3. Providing the scientific research tools that allow the student to use the methodological processes for pedagogical research of the language and applied linguistics applied to the English language training. 	24	66 credits
Master in Education with a Specialization in Higher Education	FPMME	Master in Education with a Specialization in Higher Education	<ol style="list-style-type: none"> 1. To provide a comprehensive and up-to-date training, as well as to provide the basis for the development of the academic and vocational skills required for teaching in any of the different teaching-learning contexts that may arise. 2. To ground professional practice on current knowledge, in new or unfamiliar educational settings; to provide insights into the nature of teaching and learning in general; and to develop the competencies, knowledge, skills and practical resources necessary to complete that theoretical basis. 3. To encourage critical thinking for a good theoretical formation and its necessary practical application, essential field of action; to develop good judgment, good decision making and problem solving; and to provide scientific research tools for the referenced contribution in innovative or current topics of higher education. 	24	60 credits
Master in Organization and Management of Educational Centers	FPCOCE	Master in Organization and Management of Educational Centers	<ol style="list-style-type: none"> 1. To provide the tools related to the study, planning, consulting and advisory services for the organization and management of educational institutions, so that knowledge and skills are developed to plan, organize, direct, control, propose and drive innovation for the improvement of educational institutions. 2. To stimulate critical reflection, the development of good judgment, good decision making and problem solving, and to provide scientific research tools for contributions in innovative or current educational issues. 	24	60 credits

Department of Language and Communication Science					
Name	Code	Degree Offered	General Competencies	Duration (Months)	Credits
Master in Education with a Specialty in Professor Training	FPMMEFP	Master in Education with a Specialty in Professor Training	<ol style="list-style-type: none"> 1. To provide a comprehensive and up-to-date training, as well as to provide the basis for the development of the academic and vocational skills required for teaching in any of the different teaching-learning contexts that may arise. 2. To ground professional practice on current knowledge, in new or unfamiliar educational settings; to provide insights into the nature of teaching and learning in general; and to develop the competencies, knowledge, skills and practical resources necessary to complete that theoretical basis. 3. To encourage critical thinking for a good theoretical formation and its necessary practical application, essential field of action; to develop good judgment, good decision making and problem solving; and to provide scientific research tools for the referenced contribution in innovative or current topics of Professor Training. 	24	60 credits
Master in Education with specialization in ICT in Education	FPMMETE	Master in Education with specialization in ICT in Education	<ol style="list-style-type: none"> 1. To provide a comprehensive and up-to-date training, as well as to provide the basis for the development of the academic and vocational skills required for teaching in any of the different teaching-learning contexts that may arise. 2. To ground professional practice on current knowledge, in new or unfamiliar educational settings; to provide insights into the nature of teaching and learning in general; and to develop the competencies, knowledge, skills and practical resources necessary to complete that theoretical basis. 3. To encourage critical thinking for a good theoretical formation and its necessary practical application, essential field of action; to develop good judgment, good decision making and problem solving; and to provide scientific research tools for the referenced contribution in innovative or current topics of ICT. 	24	60 credits

Department Department of Innovation, Business and New Technologies					
Name	Code	Degree Offered	General Competencies	Duration (Months)	Credits
Master in Strategic Management with a Specialty in Management	MDE	Master in Strategic Management with a Specialty in Management	<ol style="list-style-type: none"> 1. To offer education to train professionals (especially from the engineering, social sciences, management sciences and economics fields) in the area and practice of Strategic Management, by providing executive thinking to allow the student to assume their current and/or desired managerial positions, or to develop their professional trajectory in the field of organizational consulting 2. To teach in new or unfamiliar environments within the broad contexts related to their area of study. Thus, the student can apply the knowledge acquired (making judgments and decisions and solving problems). All this will help the student to understand the strategic process of organizational management, to assume roles within the strategic management process and to create proposals that integrated globalized and local processes to run a business. 3. To provide scientific research tools that will allow the student to conduct research or produce creative work in an ethical manner, thus showing mastery of the content 	24	66 credits

Department Department of Innovation, Business and New Technologies					
Name	Code	Degree Offered	General Competencies	Duration (Months)	Credits
Master in Strategic Management with a Specialty in Information Technology	MDETI	Master in Strategic Management with a Specialty in Information Technology	<ol style="list-style-type: none"> 1. To provide knowledge to professionals of different degrees, as well as the skills and abilities necessary to run a managerial position of Systems and ICT, to direct an organizational change project using ICT or to advise companies that need to respond to the competitiveness of new businesses 2. To provide the foundations of business innovation that ensure that strategies and NICT strategies are aligned and are coherent with business development, from strategic management to personnel management, with an emphasis on continuous and permanent changes. 3. To teach in new or unfamiliar environments within the broad contexts related to their area of study. Thus, the student can apply the knowledge acquired (making judgments and decisions and solving problems). In addition, the student will receive scientific research tools that will allow them to conduct research or produce creative work in an ethical manner, thus showing mastery of the content. 	24	66 credits
Master in Strategic Management with a Specialty in Telecommunications	MDETEL	Master in Strategic Management with a Specialty in Telecommunications	<ol style="list-style-type: none"> 1. To provide an understanding of the Telecommunication networks and services for those individuals that wish to understand the concept from the organizational and global society point of view, with a strategic perspective integrated into the social dynamic and current economics, while acquiring an overall knowledge of the different technological possibilities for current and future networks. 2. Teaching about new or relatively unknown environments within broad contexts that are related to their area of study, so that the student may propose and implement organizational strategies based on Telecommunications and/or integrate Telecommunications in a business, formulating judgments, making decisions and solving problems. 3. Provide special attention to the different services provided by networks and telecommunications, and the new business opportunities that companies offer. To also provide the basis for business innovation seated in strategic management and aligned to the organizational strategies with those of Telecommunication strategies and to provide the tools for scientific research that will enable the student to conduct research or produce creative work, and so demonstrating a mastery of the material in an ethical manner. 	24	66 credits

Department of Projects					
Name	Code	Degree Offered	General Competencies	Duration (Months)	Credits
Doctorate in Projects with a Specialty in Research	DODP	Doctorate in Projects with a Specialty in Research	<ol style="list-style-type: none"> 1. To provide students with a solid scientific training, providing a specialization profile in research and emerging in a field in the area of project design. 2. To teach in new or little known environments within broad contexts related to their area of study so that students can apply the knowledge acquired, making judgments, taking decisions and solving problems in the conception, design and practice of projects. 3. To provide scientific research tools that allow the student to conduct and develop original research, demonstrating mastery of the material in an ethical manner. 	63	81 credits
Master in Project Design, Administration and Management	MDGDP	Master in Project Design, Administration and Management	<ol style="list-style-type: none"> 1. Providing high level study discipline for professionals with college training in any knowledge field who have the inquisitiveness to get involved in the world of projects in a responsible manner, allowing to manage in the field of project teaching and research and/or the professional field. 2. Teaching in new or little known settings in wide contexts related to project design, operation and management, from its formulation to its subsequent analysis, regardless of its origin and purpose, so the student can apply the acquired knowledge, formulate opinions, make decisions and solve problems. 3. Providing training in the use of up-to-date computerized tools in the professional field and in the pedagogical expression of theoretical fundamentals and practical cases, the application of the technological tools for project programming and management and scientific research tools that allow the student to lead researches or produce creative work in an ethic manner, proving mastery of the material. 	24	66 credits
Master in Project Design, Administration and Management with a Specialty in Architecture and Urban Planning	MPAU	Master in Project Design, Administration and Management with a Specialty in Architecture and Urban Planning	<ol style="list-style-type: none"> 1. Offering knowledge on organized urban growth and the physical modification of the city by means of all interventions, based in urban-architectonic project methodology from a comprehensive perspective of project design, operation and management with the goal of training professionals with high social and ethic compromise and a global vision on what the involvement of a city implies. 2. Teaching in new or little known settings in wide contexts related to their field of study so the student can apply the acquired knowledge, formulating opinions, making decisions and using methodologies to solve urban and architectonic problems which can lead to redesign the physical spaces occupied by humans nowadays. 3. To provide scientific research tools that will allow the student to produce creative work in an ethical manner, thus showing mastery of the content 	24	67 credits

Department of Projects					
Name	Code	Degree Offered	General Competencies	Duration (Months)	Credits
Master in Project Design, Administration and Management with a Specialty in Innovation and Product	MDPIP	Master in Project Design, Administration and Management with a Specialty in Innovation and Product	<ol style="list-style-type: none"> 1. To provide professionals with knowledge in the fields of innovative product design. In other words, any tangible or intangible element that is produced by a project, with a strong presence of the "design" characteristic in its development phases. 2. To teach in new or unfamiliar environments within the broad contexts related to their area of study. Thus, the student can apply the knowledge acquired (making judgments and decisions and solving problems) in all phases of innovative product design, from the development phase to the subsequent analysis. 3. To provide scientific research tools that will allow the student to conduct research or produce creative work in an ethical manner. Thus, showing mastery of the content and validating the training of professionals with high social and commitment and with an open vision to incorporate new development processes (design) of innovative projects. 	24	66 credits

Department of Environment and Sustainability					
Name	Code	Degree Offered	General Competencies	Duration (Months)	Credits
Master in Environmental Management and Auditing	MAMGA	Master in Environmental Management and Auditing	<ol style="list-style-type: none"> 1. To provide university graduates who have an intermediate or higher degree with environmental training in management and environmental audits in order to improve their skills in the professional contexts in which they work, or to guide work expectations. 2. To teach advanced specialized and multidisciplinary education in new or unfamiliar environments within the broad contexts. Thus, the student can apply the knowledge acquired (making judgments and decisions and solving problems). This will allow the student to work in the fields of consulting and research. In addition, it will lead to the training of multidisciplinary environmental professionals who contribute to the growth of new companies or, who wish to update and improve their understanding of the new business opportunities that the environmental variable represents, should the case arise. 3. To provide scientific research tools and to facilitate the necessary integration of the environmental variable in the cultural and technological policies of the organization, so that the student can conduct research or produce creative work; thus, showing mastery of the content in an ethical manner. 	24	66 credits

Department of Health Sciences					
Name	Code	Degree Offered	General Competencies	Duration (Months)	Credits
Master in Physical Activity: Sports Training and Management	SNMAFEGD	Master in Physical Activity: Sports Training and Management	<ol style="list-style-type: none"> 1. To offer training in physical activity, sports design and planning, and the management of sports centers, aimed at professionals with diplomas and/or degrees in physical education, teachers, health and sports science professionals and all those who wish to improve their professional careers with subjects related to sports management 2. To teach in new or unfamiliar environments within the broad contexts by providing the knowledge and resources that the student will use to make judgments and decisions, and solve problems. 3. To provide scientific research tools that will allow the student to conduct research or produce creative work, thus showing mastery of the content in an ethical manner. 	24	66 credits
Master in Naturopathic Sciences	SNMCN	Master in Naturopathic Sciences	<ol style="list-style-type: none"> 1. To train professionals in the field of Naturopathy who will contribute in a relevant way to the scientific development of the arts and health sciences, and of a more productive and healthy society. They will be able to educate and guide on the different aspects and modalities of Naturopathy (techniques, lifestyles and natural therapies that are in harmony with this practice); and to practice therapeutic methods. 2. To teach in new or unfamiliar environments of the Naturopathic sciences and to interact and participate with doctors and other health professionals in the interdisciplinary management of the patient's health. They will reflect on their own teaching and professional development and thus, apply their knowledge to prescribe and recommend natural or integral food and other natural products that do not require a doctor's prescription by exercising good judgment, making decisions and solving problems. 3. To provide scientific research tools that will allow the student to use methodological processes for applied research in the field of Naturopathic sciences. 	48	94 credits

Curriculums

Department of Language and Communication Science

Doctorate in Education with a Specialty in Research

UNIVERSIDAD INTERNACIONAL IBEROAMERICANA (UNIB) Doctorate in Education with a Specialty in Research (75 CREDITS - 1,125 HOURS) - 5 YEARS			
Phase I: Introductory courses			
Code	Subject name	Academic Term	Credits
D0005	Research Methodology 1. Fundamentals.	3 months	6
D00014	Research Methodology II. Paradigms and Methods	1.5 month	3
D0011	Research Seminar (Doctoral Worksheet)	1.5 month	3
Total		6 months	12
Phase II: Modular courses			
Code	Subject name (The student should indicate the subjects they wish to study for this phase. The total number of credits of the chosen subjects should be a minimum of 24 and a maximum of 30)	Academic Term	Credits
FP117	Learning Theories and the Methodological Approaches in Education	2 months	4
FP118	Curricular Design and Programming	2 months	4
FP119	Learning Factors	3 months	6
FP120	Creation, Adaptation and Evaluation of Materials	2.5 months	5
FP121	Skills Development	2 months	4
FP122	Fundamentals of Special Education: Processes of Attention to Diversity	2 months	4
FP123	Educational Guidance in Mentoring	3 months	6
FP124	Applied Didactics	3 months	6
FP125	Physical Activity Applied to Education, Health and Performance	3 months	6
FP126	ICT in Education and Learning Theories	1.5 months	3
FP127	Organization and Management of Educational Centers	3 months	6
Total		1 year^a	24
Phase III: Research			
Code	Subject name	Academic Term	Credits
D0006	Research Work I	2 months	5
D0007	Research Work II	2 months	5
D0008	Thesis Proposal	8 months	4
Total		1 year	14
Phase IV: Thesis Development			
Code	Subject name	Academic Term	Credits
D0009	Thesis Development	30 months	15
D0010	Thesis Dissertation		10
Total		2.5 years	25

a) One year represents the sum of the months corresponding to those courses that the student has selected and not the sum for the column.

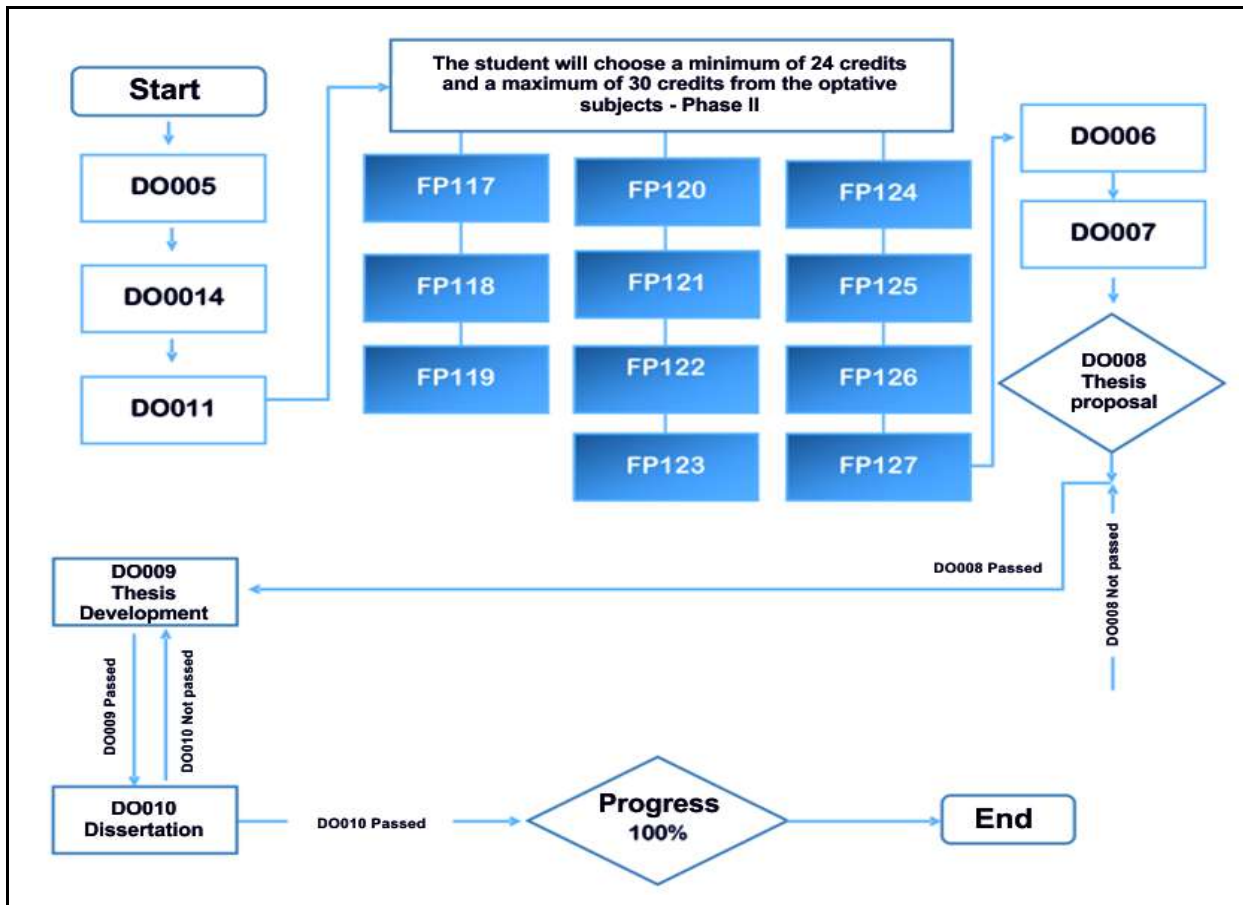


Figura 2: Flow Chart for the Doctorate in Education with a Specialty in Research.

Master in Teaching Spanish as a Foreign Language

Core subjects: **15 credits**

Requirements: **51 credits**

Electives: **0 credits**

The student will take a minimum of 66 credits.

	Code	Subject	Pre-requisites	Credits
Core subjects	FP017	Classroom Management.	N/A	3
	FP018	Observation and Research in the Classroom	N/A	3
	FP019	Second Language Acquisition	N/A	3
	FP020	Individual Factors in Learning	N/A	3
	FP021	Learning Strategies	N/A	3
Requirements	FP022	Communication and Pragmalinguistic Proficiency	N/A	3
	FP023	Language, Culture and Bilingualism	N/A	3
	FP038	Spanish Grammar for Spanish as Foreign Language Teachers	N/A	3
	FP025	Spanish and its Varieties	N/A	3
	FP026	Teaching Vocabulary	N/A	3
	FP027	Methodological Bases	N/A	3
	FP028	Developing Skills in the Classroom	N/A	3
	FP029	Creation, Adaptation and Evaluation of Materials and Resources	N/A	3
	FP030	Educational Technology in Language Learning	N/A	3
	FP031	Projects and Tasks	N/A	3
	FP032	Evaluation of the Learning Language Process	N/A	3
	FP033	Curriculum Design and Programming: Theory and Practice	N/A	3
	FP034	Practicum	N/A	5
	Thesis			
		Master Thesis	N/A	10
TOTAL				66

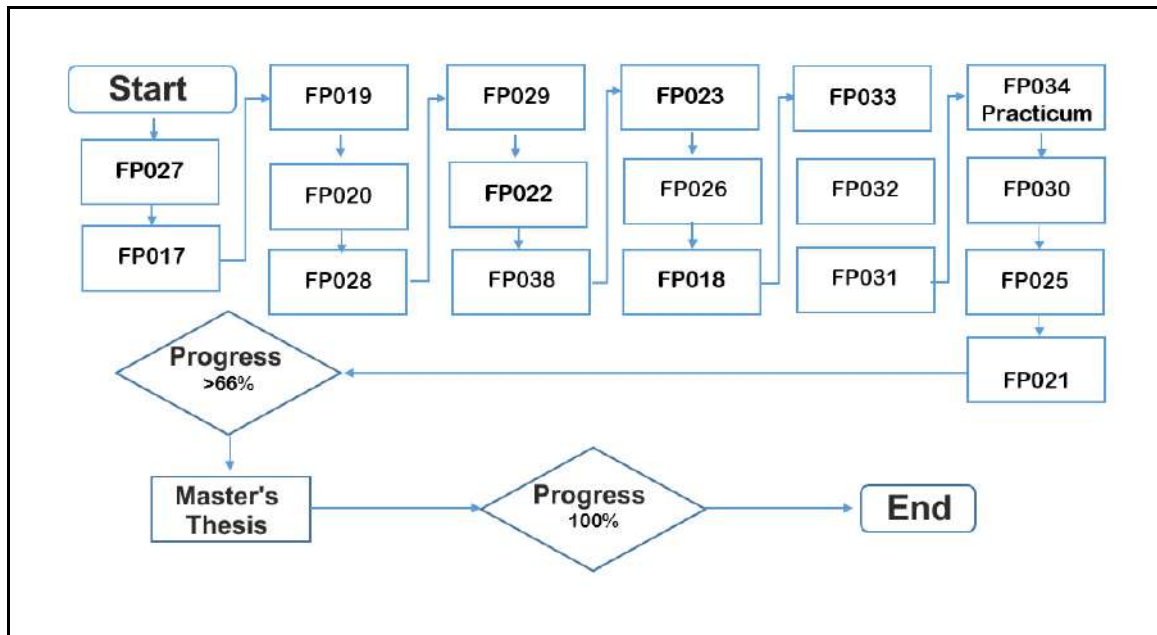


Figura 3: Flow Chart for the Master in Teaching Spanish as a Foreign Language.

Master in Teaching English as a Foreign Language

Core subjects: **18 credits**

Requirements: **48 credits**

Electives: **0 credits**

This program is only offered in English.

The student will take a minimum of 66 credits.

	Code	Subject	Pre-requisites	Credits	
Core subjects	FP003	Second Language Acquisition	N/A	3	
	FP005	Teaching Pronunciation	N/A	3	
	FP004	Individual Factors in the Learner's Development.	N/A	3	
	FP002	Observation and Research in the Language Classroom	N/A	3	
	FP001	Approaches to Language in the Classroom Context	N/A	3	
	FP037	Content & Language Integrated Learning	N/A	3	
Requirements	FP006	Methodological Approaches	N/A	3	
	FP008	Developing Language Skills in the Classroom	N/A	3	
	FP009	Materials and Resources in EFL - Design, Creation, Adaptation and Evaluation	N/A	3	
	FP007	Classroom Management - Techniques and Reflections on Practice	N/A	3	
	FP010	Computer Assisted Language Learning	N/A	3	
	FP036	Teaching English through Translation	N/A	3	
	FP011	Tasks and Projects	N/A	3	
	FP014	Learning Strategies	N/A	3	
	FP013	English in the Community	N/A	3	
	FP012	Assessment and Testing in the Classroom	N/A	3	
	FP015	Curriculum and Course Design - principles and practice	N/A	3	
	FP034	Practicum	N/A	5	
	Thesis				
		Master Thesis		N/A	10
	TOTAL				66

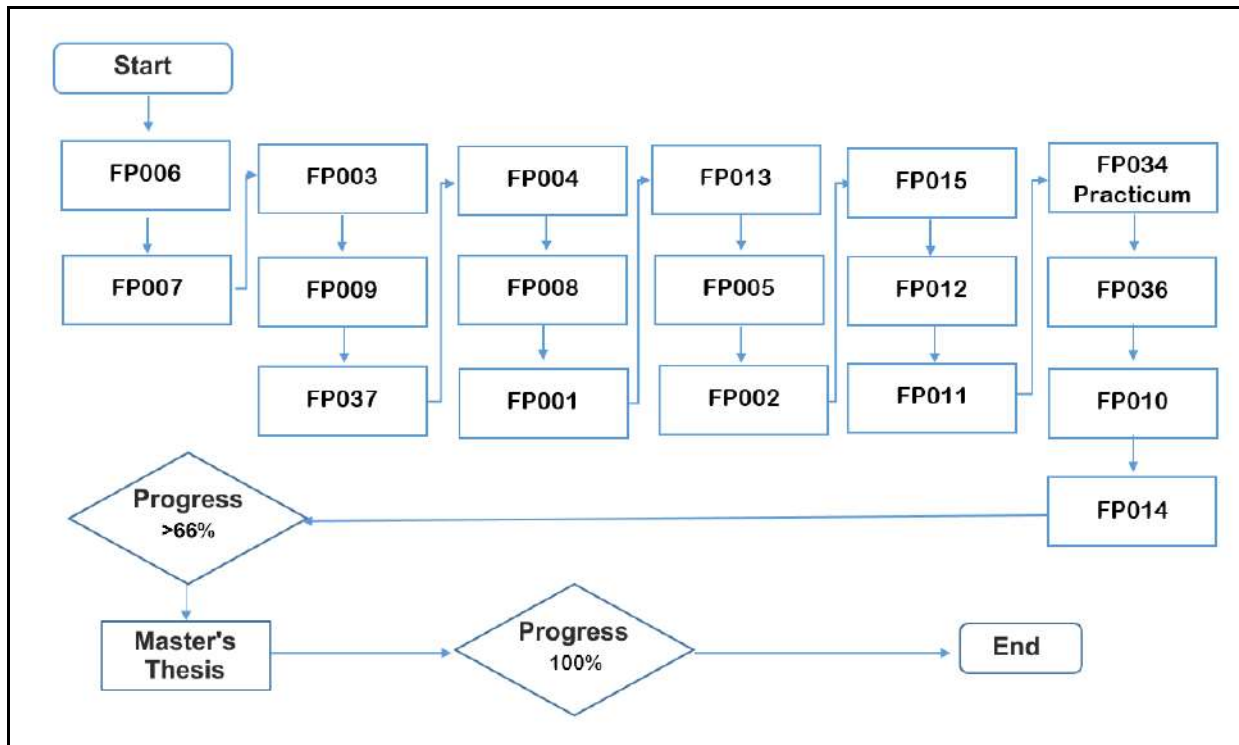


Figura 4: Flow Chart for the Master in Teaching English as a Foreign Language.

Master in Education with a Specialization in Higher Education

Core subjects: **34 credits**

Requirements: **13 credits**

Electives: **13 credits**

The student will take a minimum of 60 credits.

	Code	Subject	Pre-requisites	Credits
Core subjects	FP101	Learning Theories and the Methodological Approaches in Education	N/A	3
	FP102	Strategic Learning and Professional Development	N/A	3
	FP087	Learning Factors	N/A	3
	FP079	Mentoring within the Education System	N/A	3
	FP077	ICT in the Classroom. Educational Applications and Use of Resources	N/A	3
	FP078	Interculturality and Education	N/A	3
	FP080	Conflict Transformation and Resolution in the School Setting	N/A	3
	FP084	Environmental Education in Formal Education	N/A	3
	FP103	Fundamentals of Special Education: Processes of Attention to Diversity	N/A	3
	FP104	Organization and Management of Educational Centers	N/A	3
	FP105	Portfolio I	N/A	1
	FP092	Methodology of Scientific Research	N/A	3
Electives	FP173	Educational Quality, Evaluation and Innovation in Higher Education	N/A	3
	FP171	Educational Modalities in the University Context: Face-to-face, Blended and Distance	N/A	3
	FP176	Professional Development and Reflective Practice of University Professors	N/A	3
	FP179	Teaching Methodologies and Strategies in the University Classroom	N/A	2
	FP180	Learning Assessment in the University Context	N/A	2
Requirements	Thesis			
	FP108	Portfolio II	N/A	1
	FP116	Portfolio III	N/A	2
	FPEE01	Master's Final Project	N/A	10
TOTAL				60

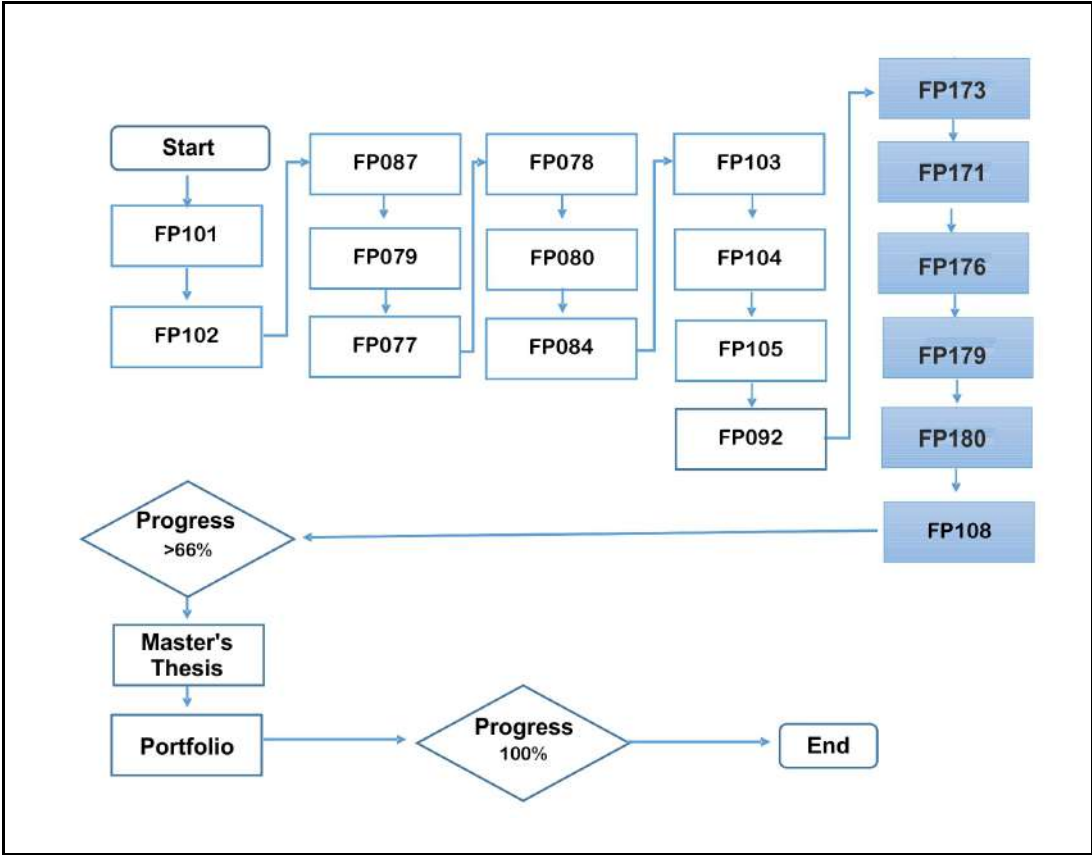


Figura 5: Flow Chart for the Master in Education with a Specialty in Higher Education.

Master in Education with a Specialty in the Organization and Management of Educational Centers

Core subjects: **34 credits**

Requirements: **13 credits**

Electives: **13 credits**

The student will take a minimum of 60 credits.

	Code	Subject	Pre-requisites	Credits
Core subjects	FP101	Learning Theories and the Methodological Approaches in Education	N/A	3
	FP102	Strategic Learning and Professional Development	N/A	3
	FP087	Learning Factors	N/A	3
	FP077	ICT in the Classroom. Educational Applications and Use of Resources	N/A	3
	FP080	Conflict Transformation and Resolution in the School Setting	N/A	3
	FP079	Mentoring within the Education System	N/A	3
	FP078	Interculturality and Education	N/A	3
	FP084	Environmental Education in Formal Education	N/A	3
	FP103	Fundamentals of Special Education: Processes of Attention to Diversity	N/A	3
	FP104	Organization and Management of Educational Centers	N/A	3
	FP092	Methodology of Scientific Research	N/A	3
	FP105	Portfolio I	N/A	1
Electives	FP082	Project Planning and Management	N/A	3
	FP081	Strategic Planning and Management	N/A	3
	FP113	E-Business and its Integrations in Corporative Systems for Educational Management	N/A	3
	FP114	Educational Quality, Evaluation and Innovation	N/A	2
	FP115	Management Techniques for Work Teams	N/A	2
Requirements	FP108	Portfolio II	N/A	1
	FP116	Portfolio III	N/A	2
	FPEE01	Master's Final Project	N/A	10
TOTAL				60

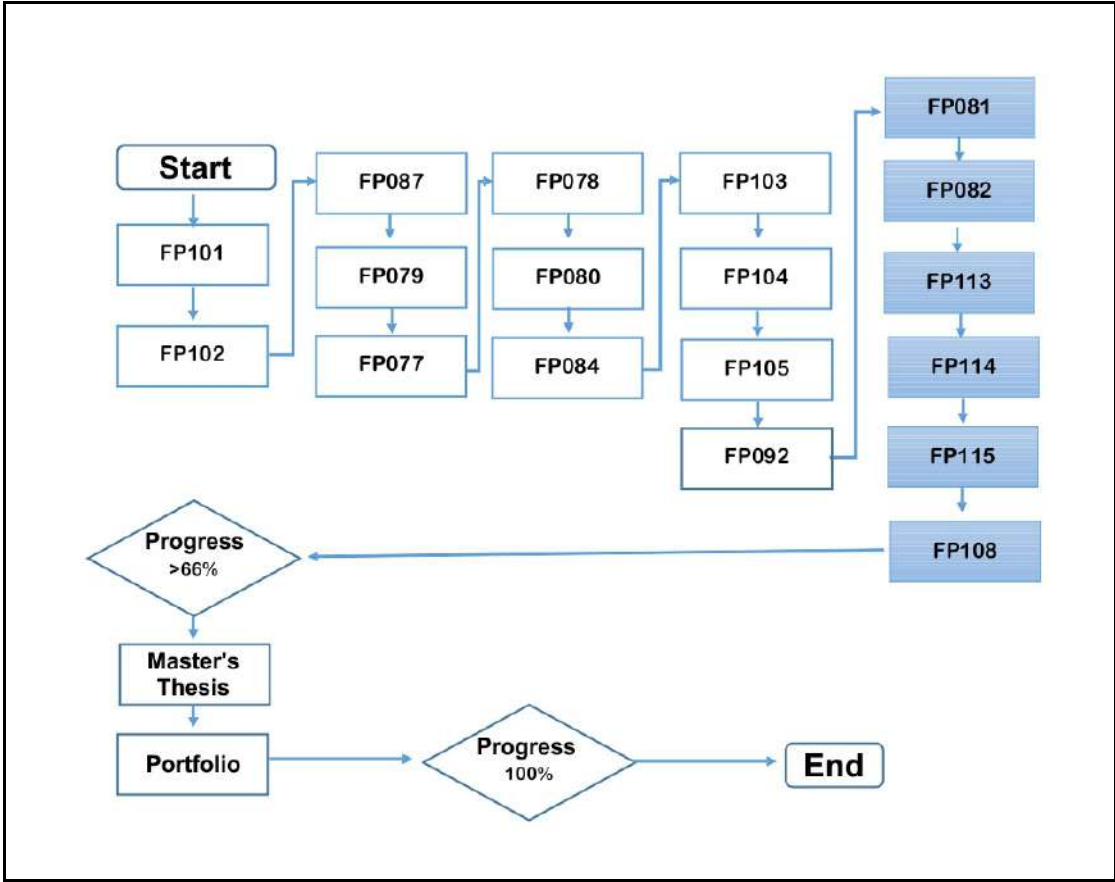


Figura 6: Flow Chart for the Master in Education with a Specialty in Organization and Management of Educational Centers.

Master in Education with a Specialty in Professor Training

Core subjects: **34 credits**

Requirements: **13 credits**

Electives: **13 credits**

The student will take a minimum of 60 credits.

	Code	Subject	Pre-requisites	Credits
Core subjects	FP101	Learning Theories and the Methodological Approaches in Education	N/A	3
	FP102	Strategic Learning and Professional Development	N/A	3
	FP087	Learning Factors	N/A	3
	FP077	ICT in the Classroom. Educational Applications and Use of Resources	N/A	3
	FP080	Conflict Transformation and Resolution in the School Setting	N/A	3
	FP079	Mentoring within the Education System	N/A	3
	FP078	Interculturality and Education	N/A	3
	FP084	Environmental Education in Formal Education	N/A	3
	FP103	Fundamentals of Special Education: Processes of Attention to Diversity	N/A	3
	FP104	Organization and Management of Educational Centers	N/A	3
	FP092	Methodology of Scientific Research	N/A	3
Electives	FP105	Portfolio I	N/A	1
	FP106	Curricular Design, Programming and Development of Competencies	N/A	3
	FP090	Learning Evaluation	N/A	3
	FP107	Learning Methodologies in the Classroom	N/A	3
	FP088	Creation, Adaptation and Evaluation of Materials	N/A	2
	FP091	Content and Language Integrated Learning	N/A	2
Requirements	Thesis			
	FP108	Portfolio II	N/A	1
	FP116	Portfolio III	N/A	2
	FPEE01	Master's Final Project	N/A	10
TOTAL				60

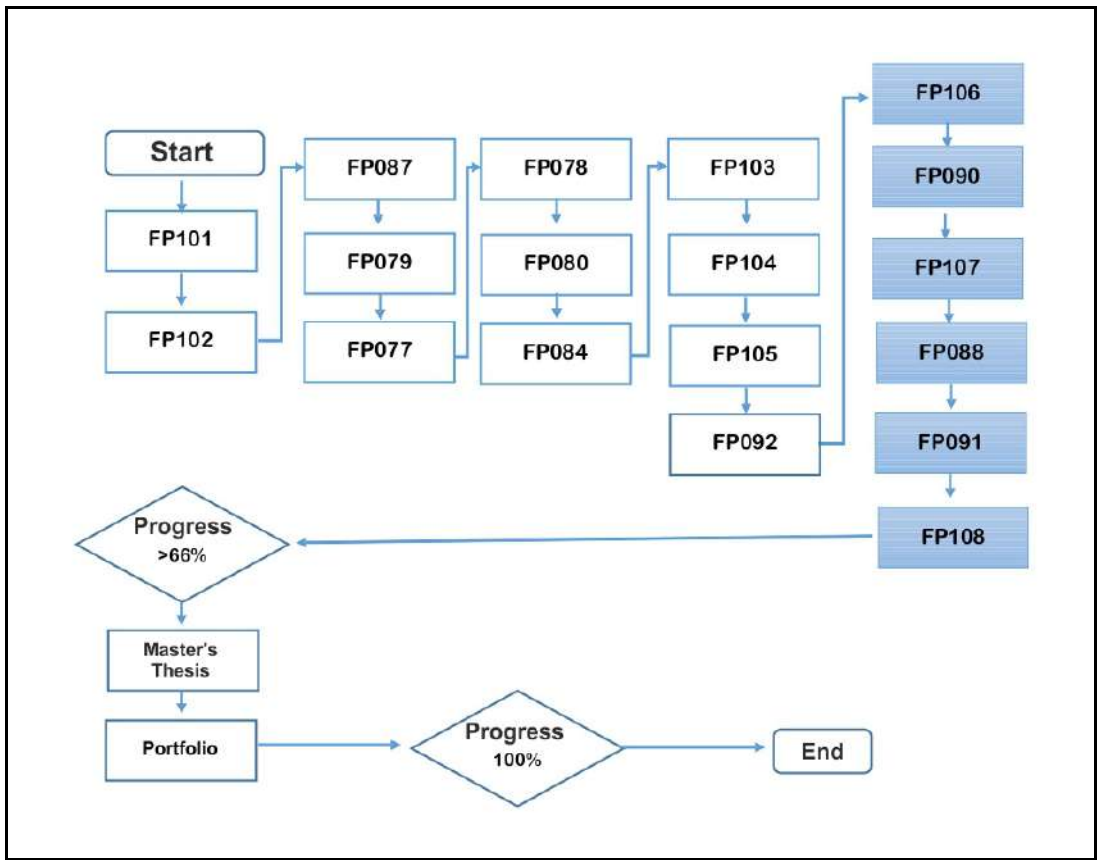


Figura 7: Flow Chart for the Master in Education with a Specialty in Professor Training.

Master in Education with a Specialty in ICT in Education

Core subjects: **34 credits**

Electives: **13 credits**

Requirements: **13 credits**

The student will take a minimum of 60 credits.

	Code	Subject	Pre-requisites	Credits
Core subjects	FP101	Learning Theories and the Methodological Approaches in Education	N/A	3
	FP102	Strategic Learning and Professional Development	N/A	3
	FP087	Learning Factors	N/A	3
	FP079	Mentoring within the Education System	N/A	3
	FP077	ICT in the Classroom. Educational Applications and Use of Resources	N/A	3
	FP078	Interculturality and Education	N/A	3
	FP080	Conflict Transformation and Resolution in the School Setting	N/A	3
	FP084	Environmental Education in Formal Education	N/A	3
	FP103	Fundamentals of Special Education: Processes of Attention to Diversity	N/A	3
	FP104	Organization and Management of Educational Centers	N/A	3
	FP092	Methodology of Scientific Research	N/A	3
	FP105	Portfolio I	N/A	1
Electives	FP109	ICT in Education and Learning Theories	N/A	3
	FP111	Analysis of Technological Resources and Design of Creative Activities	N/A	3
	FP110	Training in Virtual Learning Environments	N/A	3
	FP076	Collaborative Work in Virtual Environments	N/A	2
	FP112	Design and Evaluation of Training Proposals Based on ICT	N/A	2
Requirements	FP108	Portfolio II	N/A	1
	FP116	Portfolio III	N/A	2
	FPEE01	Master's Final Project	N/A	10
TOTAL				60

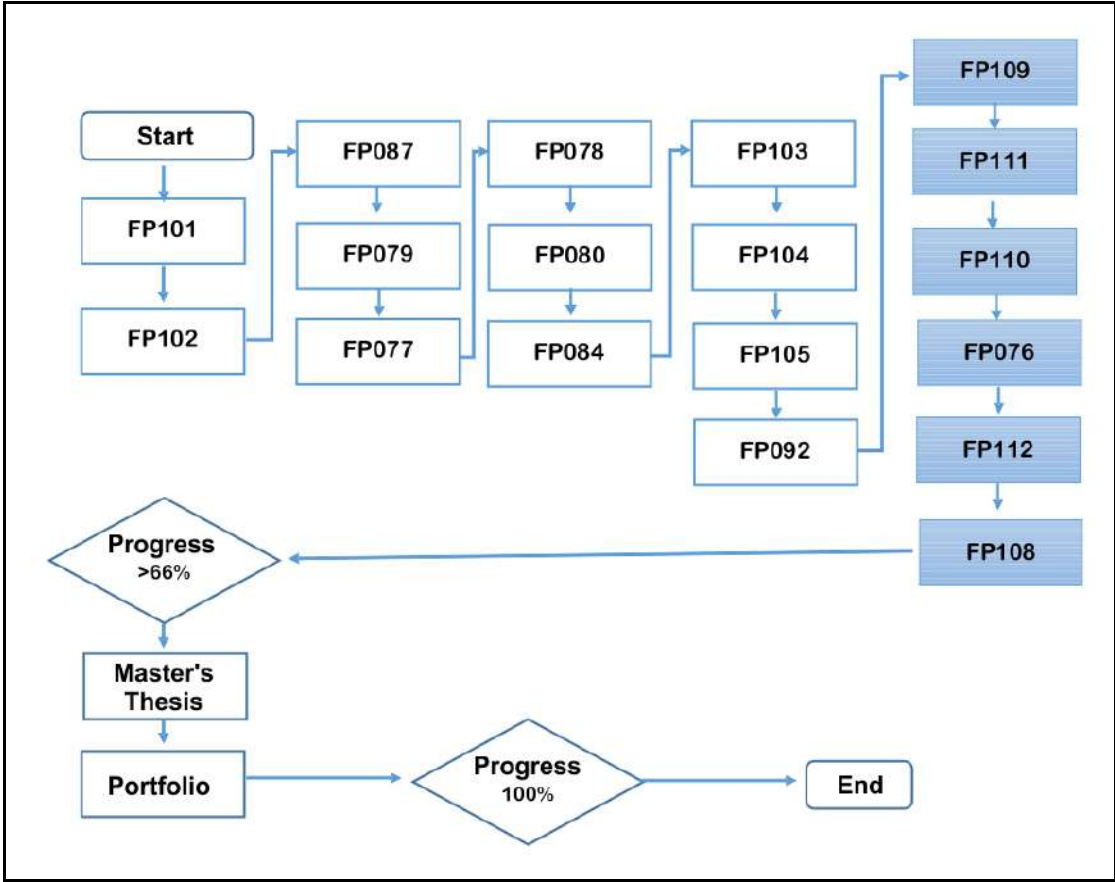


Figura 8: Flow Chart for the Master in Education with a Specialty in ICT in Education.

Department Department of Innovation, Business and New Technologies

Master in Strategic Management with a Specialty in Management

Core subjects: **9 minimum credits**

Requirements: **13 credits**

Electives: **19 minimum credits**

The student will take a minimum of 66 credits.

	Code	Subject	Pre-requisites	Credits
Core subjects	TR026	Business Administration and Management	N/A	3
	DD002	Management and Cost Control	N/A	2
	TR047	Financial Management	N/A	3
	DD004	Marketing	N/A	3
	DD152	Economy	N/A	2
	DD118	Basic Statistics	N/A	2
	DD120	Financial Mathematics	N/A	1
	DD124	Management Accounting	N/A	2
	TR046	Strategic Management of Human Resources	N/A	2
	DD040	Conflict Resolution and Negotiation Techniques	N/A	2
	DD032	Performance Evaluation and Management by Competencies	N/A	2
	TR024	Management Techniques and Organizational Leadership	N/A	2
	DD090	Business Ethics and Corporate Social Responsibilities	N/A	3
	DD041	Management Techniques for Teams	N/A	2
	DD076	Management without Distances	N/A	1
	DD026	Collaborative Work in Virtual Environments	N/A	1
	DD042	Time Management and Conducting Meetings	N/A	2
	DD043	Stress and Burnout	N/A	2
	DD044	Public Speaking Techniques	N/A	1
	IP082	Quality Management: ISO 9001	N/A	3
	IP092	ISO 45001	N/A	2
	MA098	Business Environmental Management ISO 14001	N/A	3
	DD012	Management and Operational Direction	N/A	2
	DD013	Logistics	N/A	2
	DD014	Strategic Management and Planning	N/A	3
	TR038	Project Planning and Management	N/A	3
	TI013	Reengineering, Strategy and Management of ITC Systems	N/A	3
	TI025	E-Business and its Integration with Corporate Management Systems	N/A	3
	TI017	Integration of Business Management Systems	N/A	5
	DD162	Marketing Strategy Development	N/A	2
	TI030	Network Security and Management	N/A	3
	TI011	Society of Change and Information	N/A	3
	DD068	Knowledge Management and Organizational Learning	N/A	2
TI004/ DD163	International Marketing and Commerce	N/A	4	
TI014	E-commerce and Marketing	N/A	4	
TI023	Study and Case Resolution (I, II and III)	N/A	10	

	Code	Subject	Pre-requisites	Credits
Core subjects	DD2867	Globalization and International Business	N/A	4
	DD372	Organizational Leadership and Coaching	N/A	5
Electives	Optative Module: Marketing			
	DD159	Introduction to the New Marketing	N/A	2
	DD160	Market Research	N/A	2
	DD161	Consumer-Buyer Behavior	N/A	2
	DD164	Relational Marketing	N/A	2
	DD165	Marketing Audits	N/A	1
	DD166	Product and Brand Policy Management	N/A	3
	DD167	Price Management Policy	N/A	3
	DD168	Distribution Management Policies	N/A	3
	DD169	Communication Management Policies	N/A	3
	DD170	Marketing Services	N/A	2
	DD171	Control and Marketing Plan	N/A	2
	Optative Module: Auditing			
	DD153	Financial Valuation for IAS	N/A	2
	DD122	International Accounting Standards	N/A	4.5
	DD121	International Taxation and Financing	N/A	1.5
	DD123	Financial Statements Analysis	N/A	2
	DD128	Administration and Planning of Audits	N/A	1
	DD154	Internal Control	N/A	2
	DD155	Documentation, Tests and Risks	N/A	2
	DD130	Auditing Procedures by Area	N/A	5
	DD131	Audit Reports	N/A	1
	DD119	Statistical Sample	N/A	2
	DD125	Total Quality Costs	N/A	2
	DD126	Budget and Public Accounting	N/A	3
	Optative Module: Tourism Consulting			
	TR043	Tourism Foundations	N/A	3
	TR037	IT in the Tourism Industry	N/A	4
	TR022	Hotel Business Management	N/A	4.5
	TR023	Food and Drinks Management	N/A	4.5
	TR027	Cultural Heritage and Tourism	N/A	3
	TR008	The Territory as a Tourism Resource	N/A	3
	TR028	Environmental Impact on Tourism Activities	N/A	3
	TR030	Rural Tourism and Sustainable Development	N/A	3
	TR031	Alternative Tourism and Ecotourism	N/A	3
	TR036	Strategy and Tourism Businesses on the Internet	N/A	3
	TR049	Quantitative analysis of tourism	N/A	4
	Optative Module: Family Business			
	DD108	Family Business Concepts and Characteristics	N/A	2
	DD109	Succession and Continuity in Family Business	N/A	2
	DD110	Systematic Approach Applied to Conflict in Family Businesses	N/A	2
	DD111	Professionalization of Family Business	N/A	2
	DD112	Government Structures and Bodies	N/A	2
DD113	The Family Protocol	N/A	2	

	Code	Subject	Pre-requisites	Credits	
Electives	DD114	Property Management in Family Businesses	N/A	1	
	DD115	Key Factors for Success in the Family Business	N/A	1	
	DD116	Creation and Internationalization of Family Businesses	N/A	2	
	DD143	Basic Legal Aspects of the Family Business	N/A	3	
	Optative Module: Human Resources Management and Administration				
	DD022	Organizational Structure and Change	N/A	2	
	DD024	Organizational culture and climate	N/A	2	
	DD030	Position Analysis, Description and Value	N/A	2	
	DD031	Recruitment, Selection and Promotion	N/A	2	
	DD032	Performance Evaluation and Management by Competencies	N/A	2	
	DD033	Compensations and Incentives	N/A	2	
	DD034	Training and Career Plans	N/A	2	
	DD036	Human Resources Auditing	N/A	1	
	DD039	Interpersonal Communication Techniques	N/A	1	
	Optative Module: Integrated Management for the Environment, Quality and Occupational Risk Prevention				
	IP059	Fundamentals in Occupational Risk Prevention	N/A	2	
	IP060	Occupational Safety	N/A	4	
	IP003	Industrial Hygiene	N/A	5	
	IP062	Ergonomics	N/A	3	
	IP071	Applied Psychosociology	N/A	2	
	IP078	Background and Current Status of Integrated Management	N/A	3	
	IP9001	Introduction and fundamentals of integrated management systems	N/A	2	
	IP9002	Advantages and Difficulties of The Integration of Systems, Grades, Modes and Integration System Models	N/A	3	
	IP9003	Integration of Management Systems Based on Standards and Processes	N/A	2	
	IP9004	Implementation of the Integrated Management System	N/A	2	
	IP051	Water Management: Basic Principles	N/A	5	
	IP052	Basic Waste Management	N/A	3	
	IP053	Air Pollution Treatment	N/A	5	
	IP054	Treatment of Contaminated Soils	N/A	4	
	IP002	Workplace Safety	N/A	7	
	IP076	Workplace Hygiene	N/A	7	
	IP073	Ergonomics and Applied Psychology	N/A	7	
	IP064	Training and Communication	N/A	1	
	IP004	Occupational Health	N/A	2	
	Optative Module: Health Service Management				
	DD1004	Health Economics	N/A	5	
	DD1007	Health Planning	N/A	4	
	DD1008	Health Services Management	N/A	3	
	DD1009	Health Marketing	N/A	3	
	DD1010	Assistance Quality and Patient Security	N/A	4	
	DD1012	Health Systems	N/A	4	
	DD1013	Clinical Epidemiology	N/A	5	
DD1014	Biostatistics	N/A	5		
Optative Module: Human Resources And Knowledge Management					
DD022	Organizational Structure and Change	N/A	2		
DD024	Organizational culture and climate	N/A	2		

	Code	Subject	Pre-requisites	Credits	
Electives	DD030	Position Analysis, Description and Value	N/A	2	
	DD031	Recruitment, Selection and Promotion	N/A	2	
	DD034	Training and Career Plans	N/A	2	
	DD033	Compensations and Incentives	N/A	2	
	DD036	Human Resources Auditing	N/A	1	
	DD039	Interpersonal Communication Techniques	N/A	1	
	DD045	Emotional Intelligence	N/A	1	
	DD046	Personal Marketing	N/A	1	
	DD047	Intellectual Capitol	N/A	1	
	DD048	Quality as a Management Tool for Human Resources	N/A	1	
	DD049	Neurolinguistic Programming	N/A	1	
	Optative Module: Conflict Resolution and Mediation				
	DD091/ DD092	Conflict Theory	N/A	5	
	DD093/ DD094	Emotion, Communication and Conflict	N/A	4	
	DD138	DD138-Conflict Resolution/Transformation Principles and Processes	N/A	5	
	DD097/ DD098	Mediation	N/A	4	
	DD099	National and International Law on Mediation and other Conflict Resolution Procedures	N/A	3	
	DD100	Conflict Resolution/Transformation in Schools	N/A	2	
	DD101	Conflict Resolution/Transformation in the Family	N/A	2	
	DD102	Conflict Resolution/Transformation in the Community	N/A	2	
DD103	Conflict Resolution/Transformation in the Organizational Field	N/A	2		
DD104	Conflict Resolution/Transformation in the Criminal Field	N/A	2		
DD105	Conflict Resolution/Transformation in the Health Field	N/A	1		
DD106	International Conflict Resolution/Transformation	N/A	2		
DD107	Online Dispute Resolution (ODR)	N/A	1		
Requirements	Thesis				
	FP092	Methodology of Scientific Research	N/A	3	
		Master Thesis	N/A	10	
TOTAL				66	

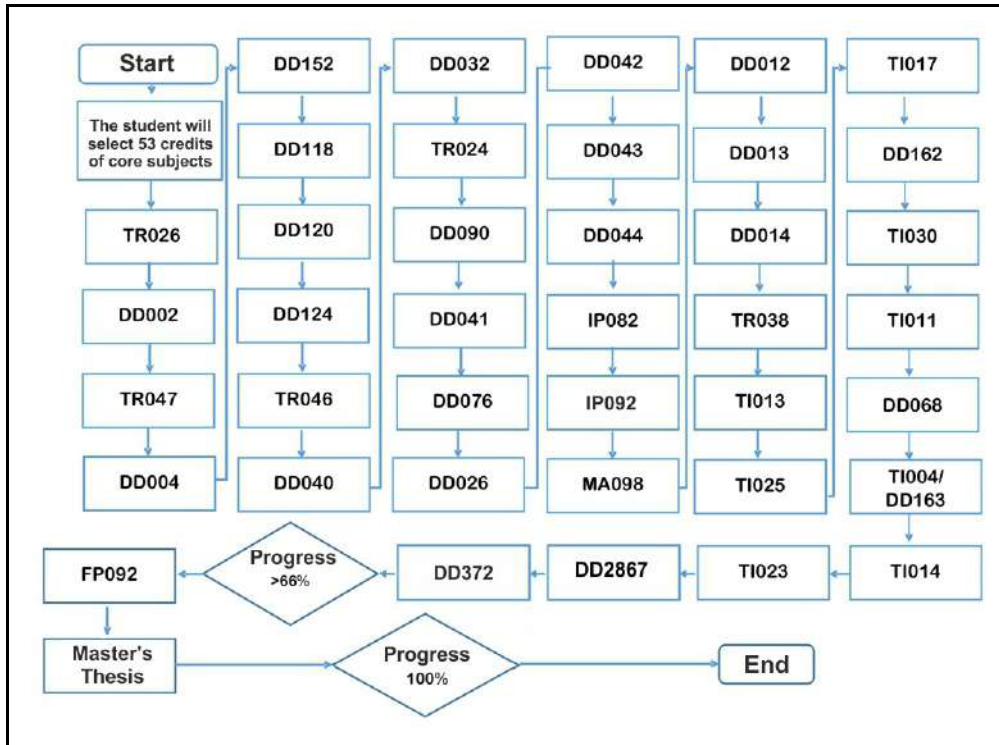


Figura 9: Flow Chart on the Master in Strategic Management with a Specialty in Management.

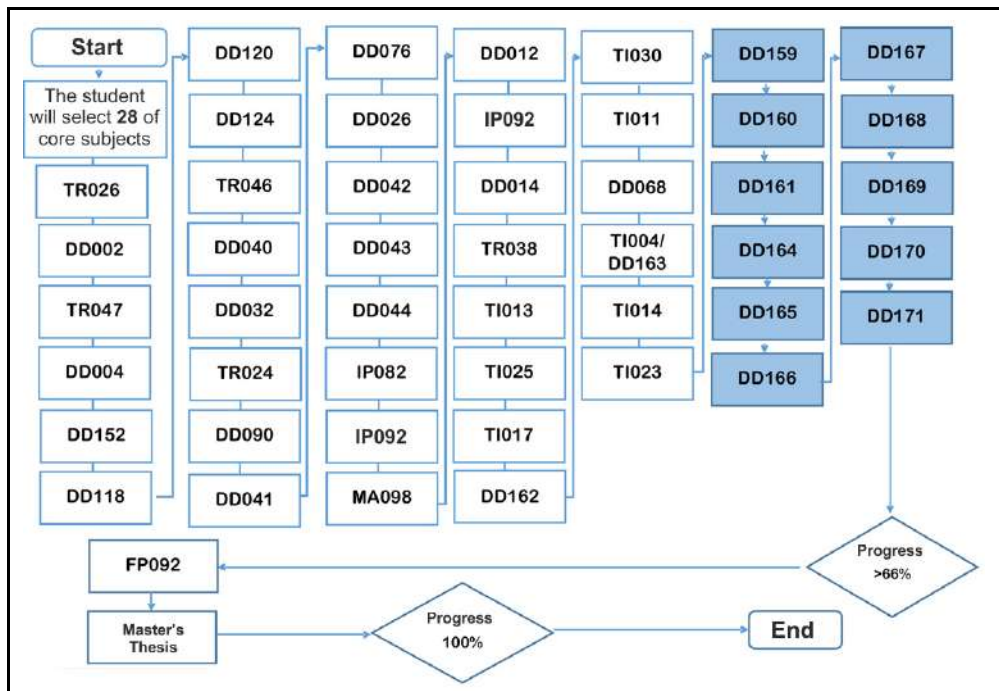


Figura 10: Flow Chart on the Master in Strategic Management with a Specialty in Management Optative Module: Marketing¹.

1. Subjects from the Optative Module are shown in blue.

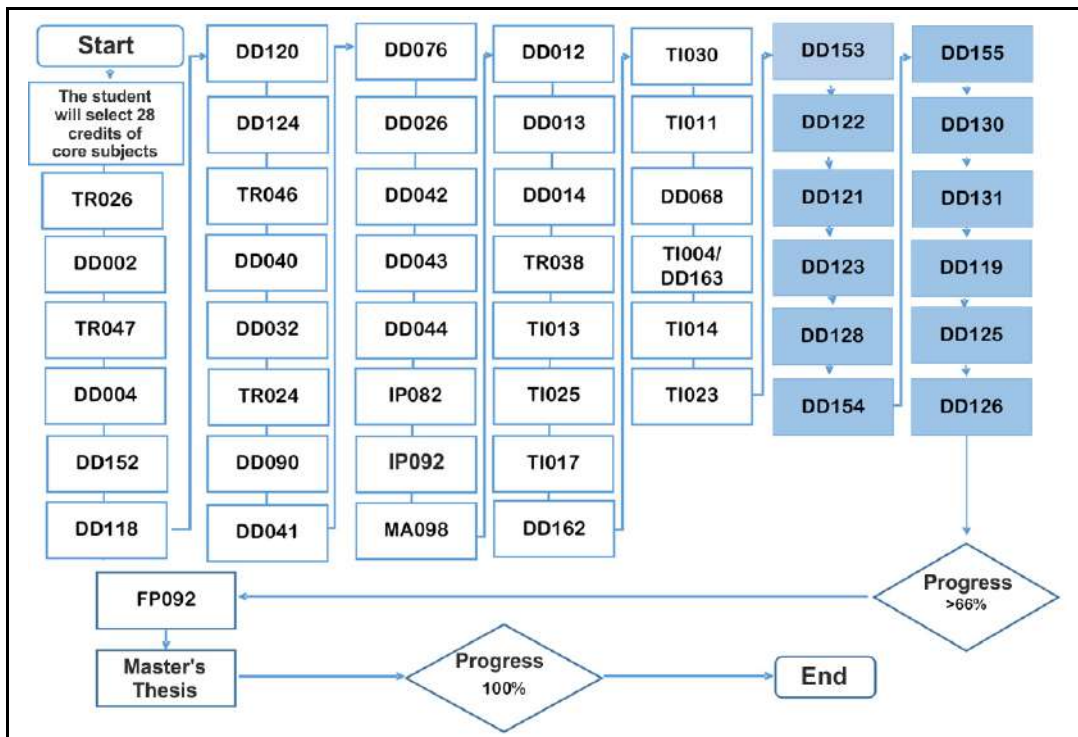


Figure 11: Flow Chart on the Master in Strategic Management with a Specialty in Management Optative Module: Auditing².

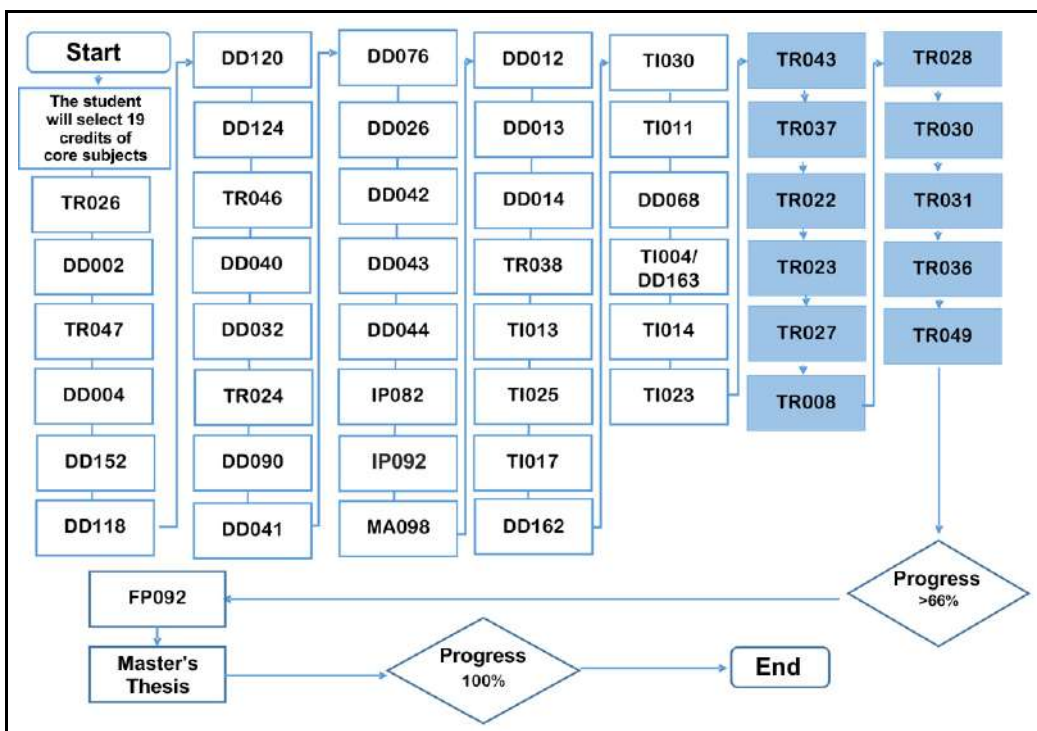


Figure 12: Flow Chart on the Master in Strategic Management with a Specialty in Management Optative Module: Tourism Consulting².

2. Subjects from the Optative Module are shown in blue.

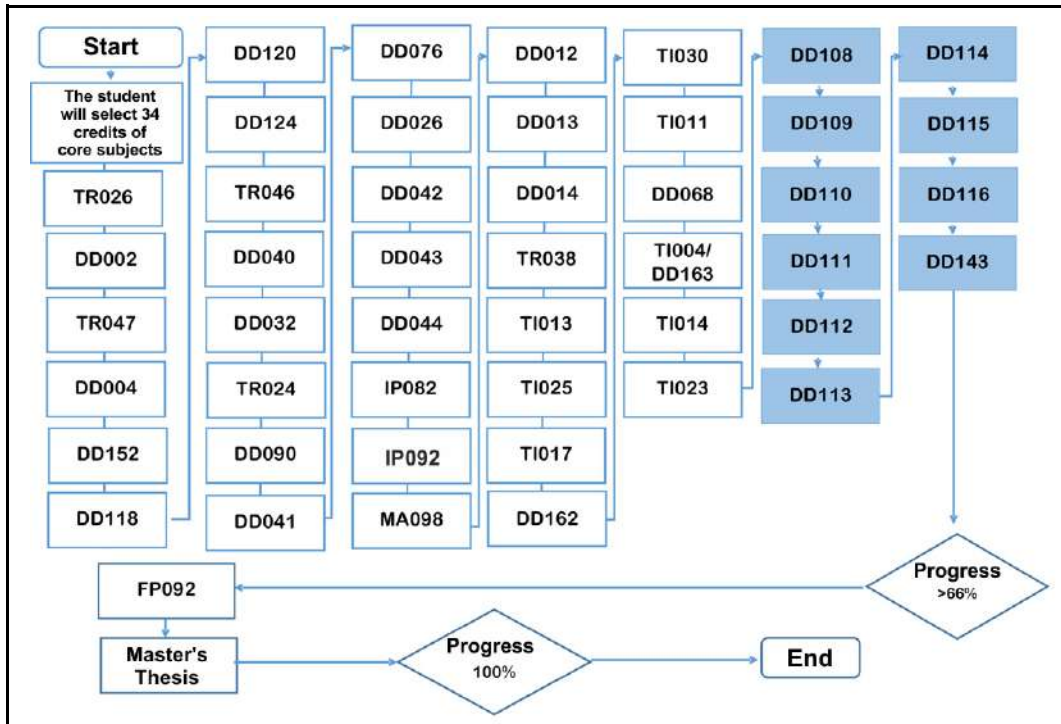


Figura 13: Flow Chart on the Master in Strategic Management with a Specialty in Management Optative Module: Family Business³.

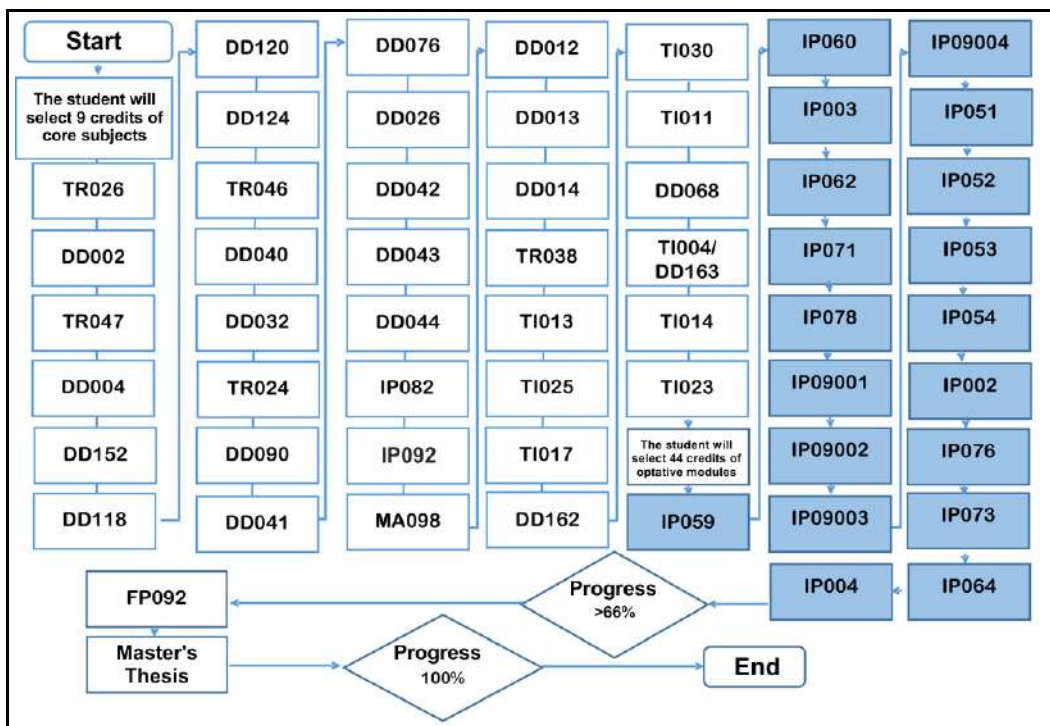


Figura 14: Flow Chart on the Master in Strategic Management with a Specialty in Management Optative Module: Integrated Management for the Environment, Quality and Occupational Risk Prevention³.

3. Subjects from the Optative Module are shown in blue.

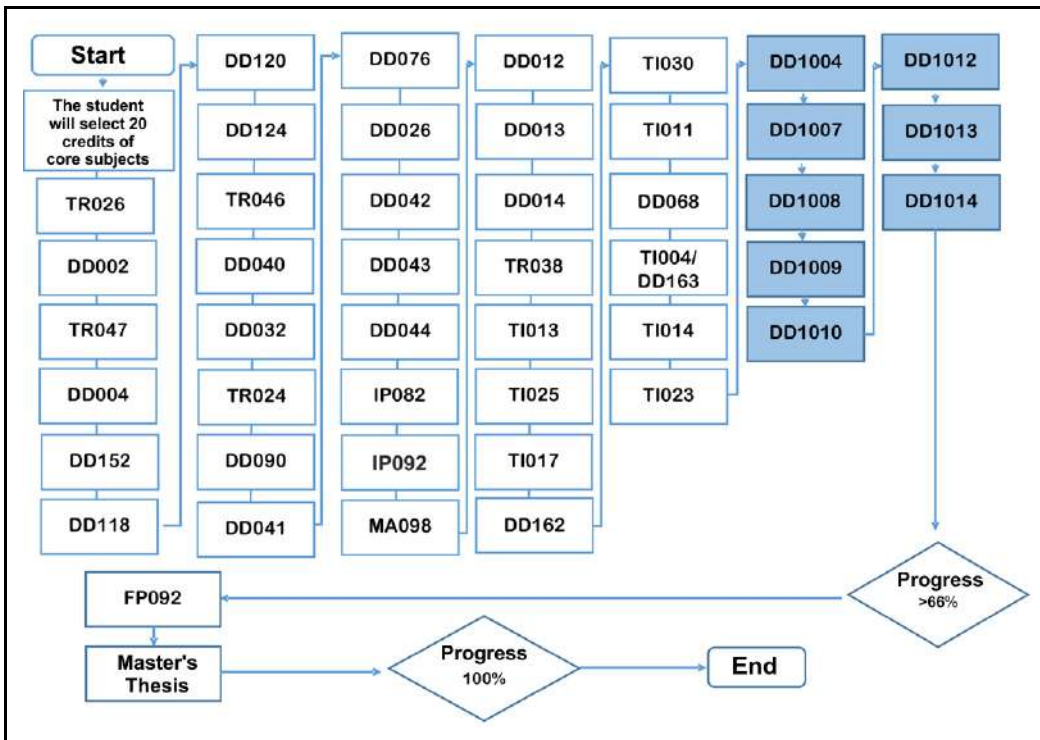


Figure 15: Flow Chart on the Master in Strategic Management with a Specialty in Management Optative Module: Health Organizations⁴.

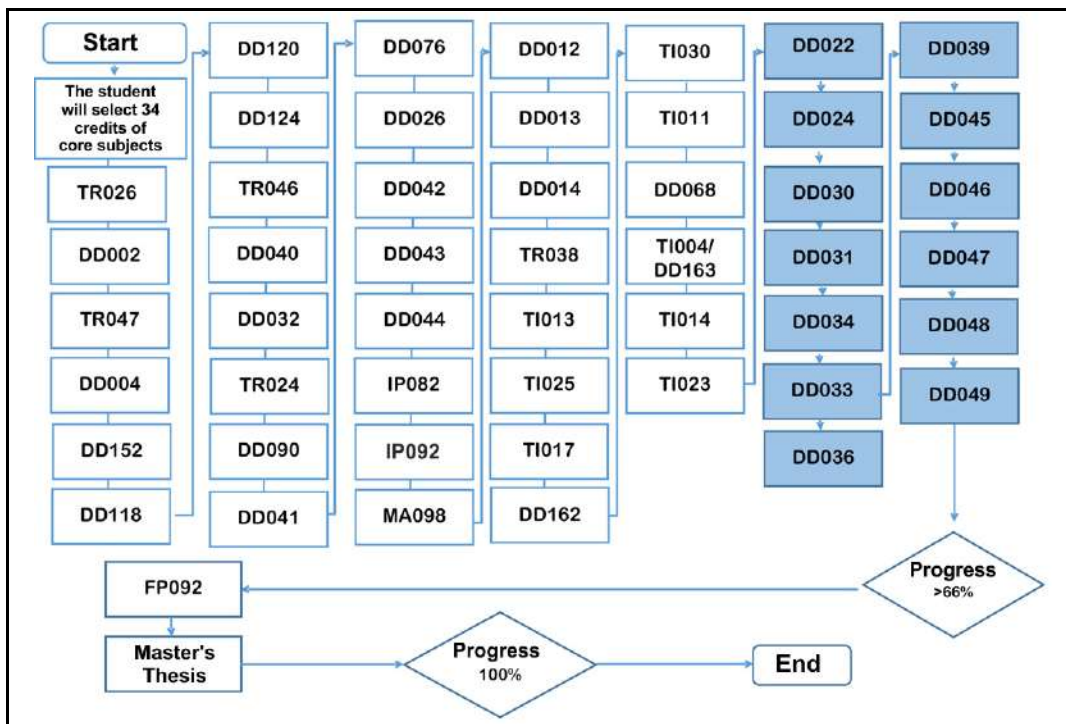


Figure 16: Flow Chart on the Master in Strategic Management with a Specialty in Management Optative Module: Human Resources Management and Knowledge Management⁴.

4. Subjects from the Optative Module are shown in blue.

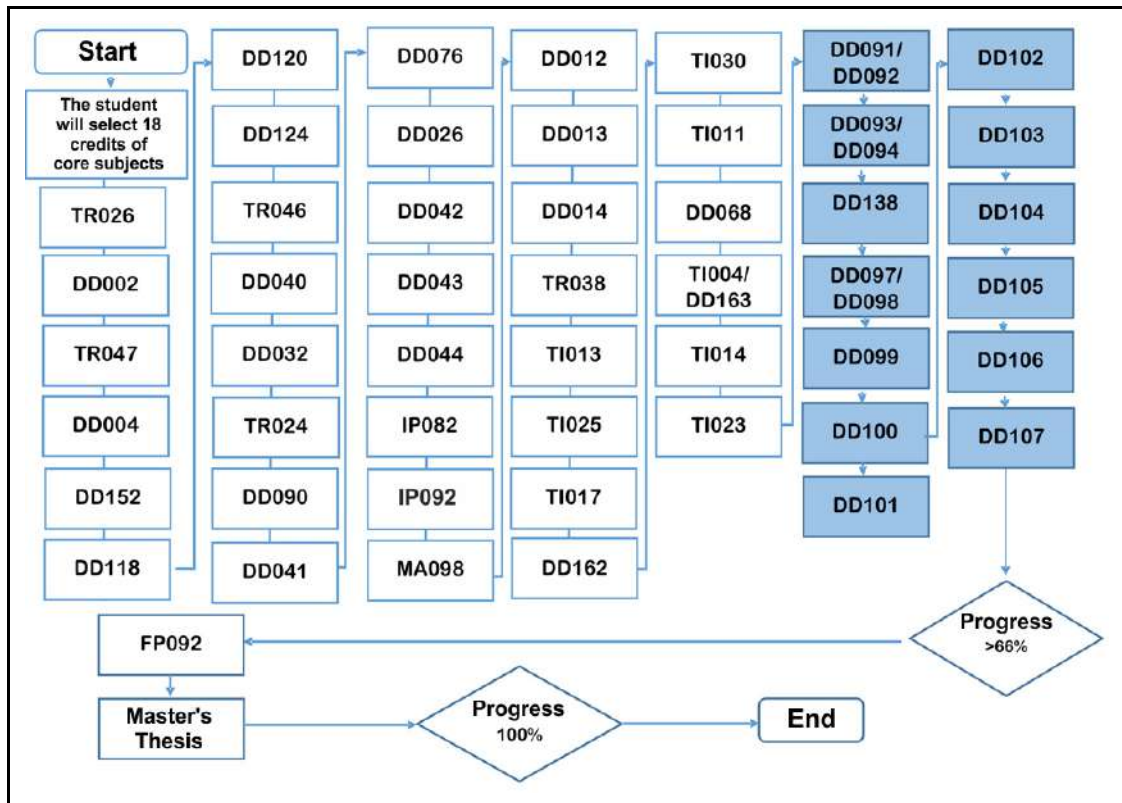


Figura 17: Flow Chart on the Master in Strategic Management with a Specialty in Management Optative Module: Conflict Resolution and Mediation⁵.

5. Subjects from the Optative Module are shown in blue.

Master in Strategic Management with a Specialty in Information Technology

Core subjects: **19 minimum credits**

Requirements: **27 credits**

Electives: **20 credits**

The student will take a minimum of 66 credits.

	Code	Subject	Pre-requisites	Credits
Core subjects	TR026	Business Administration and Management	N/A	3
	DD002	Management and Cost Control	N/A	2
	TR047	Financial Management	N/A	3
	DD004	Marketing	N/A	3
	DD152	Economy	N/A	2
	DD118	Basic Statistics	N/A	2
	DD120	Financial Mathematics	N/A	1
	DD124	Management Accounting	N/A	2
	TR046	Strategic Management of Human Resources	N/A	2
	DD040	Conflict Resolution and Negotiation Techniques	N/A	2
	DD032	Performance Evaluation and Management by Competencies	N/A	2
	TR024	Management Techniques and Organizational Leadership	N/A	2
	DD090	Business Ethics and Corporate Social Responsibilities	N/A	3
	DD041	Management Techniques for Teams	N/A	2
	DD076	Management without Distances	N/A	1
	DD026	Collaborative Work in Virtual Environments	N/A	1
	DD042	Time Management and Conducting Meetings	N/A	2
	DD043	Stress and Burnout	N/A	2
	DD044	Public Speaking Techniques	N/A	1
	IP082	Quality Management: ISO 9001	N/A	3
	IP092	ISO 45001	N/A	2
	MA098	Business Environmental Management ISO14001	N/A	3
	DD012	Management and Operational Direction	N/A	2
	DD013	Logistics	N/A	2
	DD014	Strategic Management and Planning	N/A	3
	TR038	Project Planning and Management	N/A	3
	TI013	Reengineering, Strategy and Management of ITC Systems	N/A	3
	TI025	E-Business and its Integration with Corporate Management Systems	N/A	3
	TI017	Integration of Business Management Systems	N/A	5
	DD162	Marketing Strategy Development	N/A	2
	TI030	Network Security and Management	N/A	3
	TI011	Society of Change and Information	N/A	3
	DD068	Knowledge Management and Organizational Learning	N/A	2
TI004/ DD163	International Marketing and Commerce	N/A	4	
TI014	E-commerce and Marketing	N/A	4	
TI023	Study and Case Resolution (I, II and III)	N/A	10	

	Code	Subject	Pre-requisites	Credits
Requirements	Specialty in Information Technology			
	TI015	Electronic security and legislation	N/A	4
	TI016	Business Intelligence	N/A	4
	TI018	Innovation, Culture and Work Management in the Communication Society	N/A	2
	TI043	Management and Administration of IT Projects	N/A	4
Electives	Optative Module: Software Businesses			
	TI034	Languages and Programming Paradigms	N/A	2
	TI035	Architectures, Networks and Distributive Systems	N/A	3
	TI036	Web Technology and Engineering	N/A	3
	TI037	Integral Design and Analysis of Systems and Requirements	N/A	3
	TI038	Data Model and Database Design	N/A	3
	TI040	Management of Databases and Information Resources	N/A	3
Requirements	Thesis			
	FP092	Methodology of Scientific Research	N/A	3
		Master Thesis	N/A	10
TOTAL				66

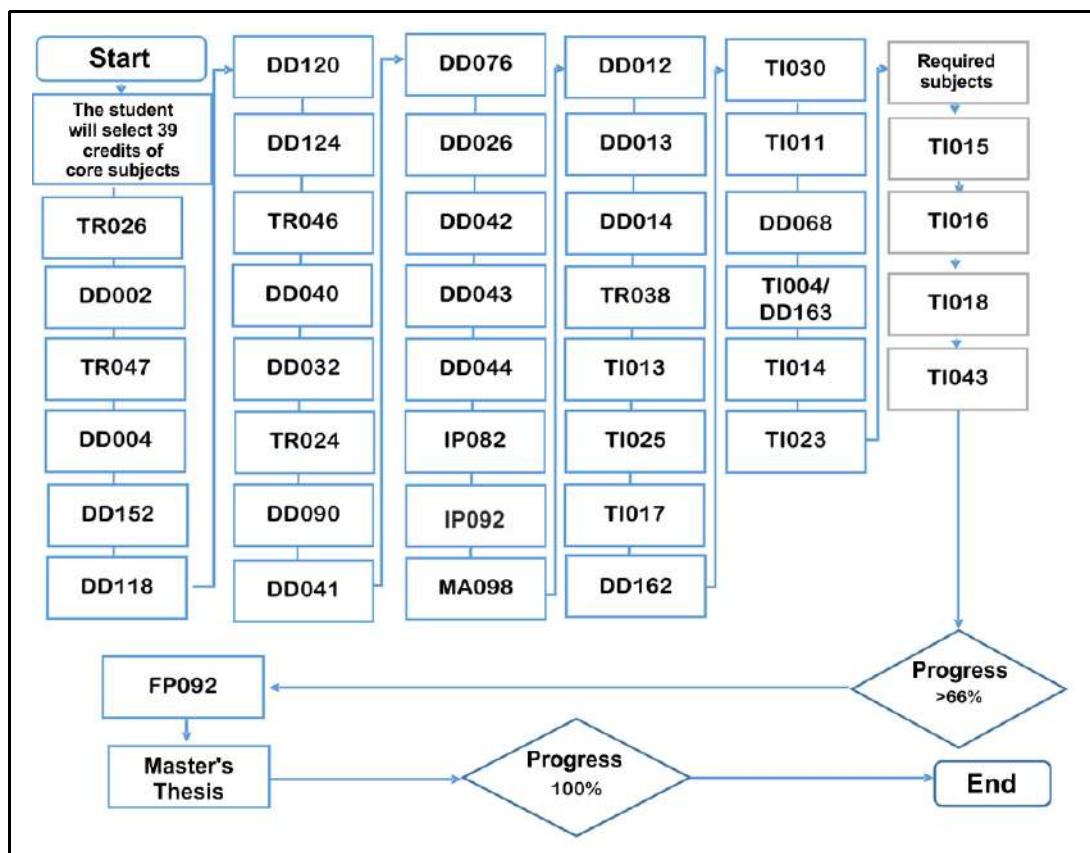


Figura 18: Flow Chart of the Master in Strategic Management With a Specialty in Information Technology Report.

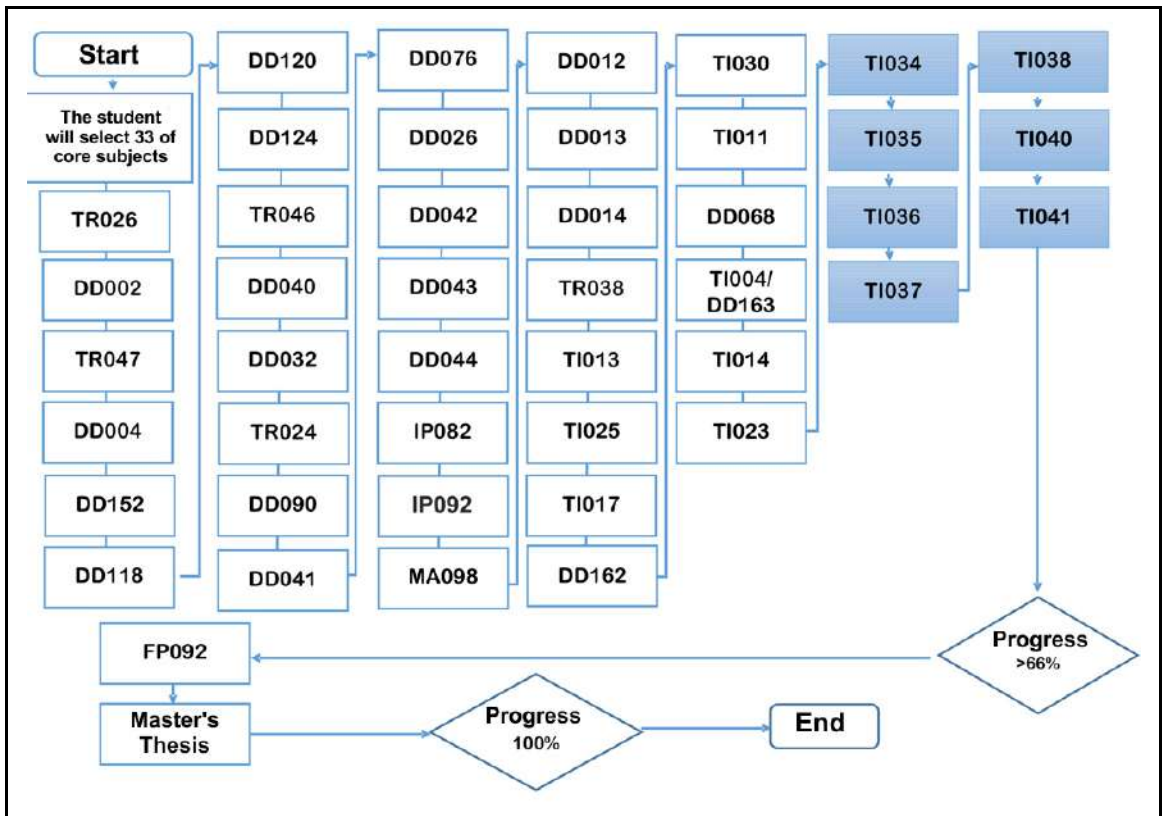


Figura 19: Flow Chart on the Master in Strategic Management with a Specialty in Information Technology Optative Module: Software Businesses⁶.

6. Subjects from the Optative Module are shown in blue.

Master in Strategic Management with a Specialty in Telecommunications

Core subjects: **32 minimum credits**

Requirements: **34 credits**

The student will take a minimum of 66 credits.

	Code	Subject	Pre-requisites	Credits
Core subjects	TR026	Business Administration and Management	N/A	3
	DD002	Management and Cost Control	N/A	2
	TR047	Financial Management	N/A	3
	DD004	Marketing	N/A	3
	DD152	Economy	N/A	2
	DD118	Basic Statistics	N/A	2
	DD120	Financial Mathematics	N/A	1
	DD124	Management Accounting	N/A	2
	TR046	Strategic Management of Human Resources	N/A	2
	DD040	Conflict Resolution and Negotiation Techniques	N/A	2
	DD032	Performance Evaluation and Management by Competencies	N/A	2
	TR024	Management Techniques and Organizational Leadership	N/A	2
	DD090	Business Ethics and Corporate Social Responsibilities	N/A	3
	DD041	Management Techniques for Teams	N/A	2
	DD076	Management without Distances	N/A	1
	DD026	Collaborative Work in Virtual Environments	N/A	1
	DD042	Time Management and Conducting Meetings	N/A	2
	DD043	Stress and Burnout	N/A	2
	DD044	Public Speaking Techniques	N/A	1
	IP082	Quality Management: ISO 9001	N/A	3
	IP092	ISO 45001	N/A	2
	MA098	Business Environmental Management ISO14001	N/A	3
	DD012	Management and Operational Direction	N/A	2
	DD013	Logistics	N/A	2
	DD014	Strategic Management and Planning	N/A	3
	TR038	Project Planning and Management	N/A	3
	TI013	Reengineering, Strategy and Management of ITC Systems	N/A	3
	TI025	E-Business and its Integration with Corporate Management Systems	N/A	3
	TI017	Integration of Business Management Systems	N/A	5
	DD162	Marketing Strategy Development	N/A	2
	TI030	Network Security and Management	N/A	3
	TI011	Society of Change and Information	N/A	3
DD068	Knowledge Management and Organizational Learning	N/A	2	
TI004/ DD163	International Marketing and Commerce	N/A	4	
TI014	E-commerce and Marketing	N/A	4	

	Code	Subject	Pre-requisites	Credits
Requirements	Specialty in Telecommunications			
	TI026	Telecommunications Marketing	N/A	3
	TI027	Technical-Business Structure of Telecommunications	N/A	3
	TI028	Telecommunication Networks	N/A	3
	TI029	Telecommunications services	N/A	2
	TI031	Telecommunications Marketing Regulations	N/A	2
	TI016	Business Intelligence	N/A	4
	TI020	E-Business Project Management	N/A	4
	Thesis			
	FP092	Methodology of Scientific Research	N/A	3
	Master Thesis	N/A	10	
TOTAL				66

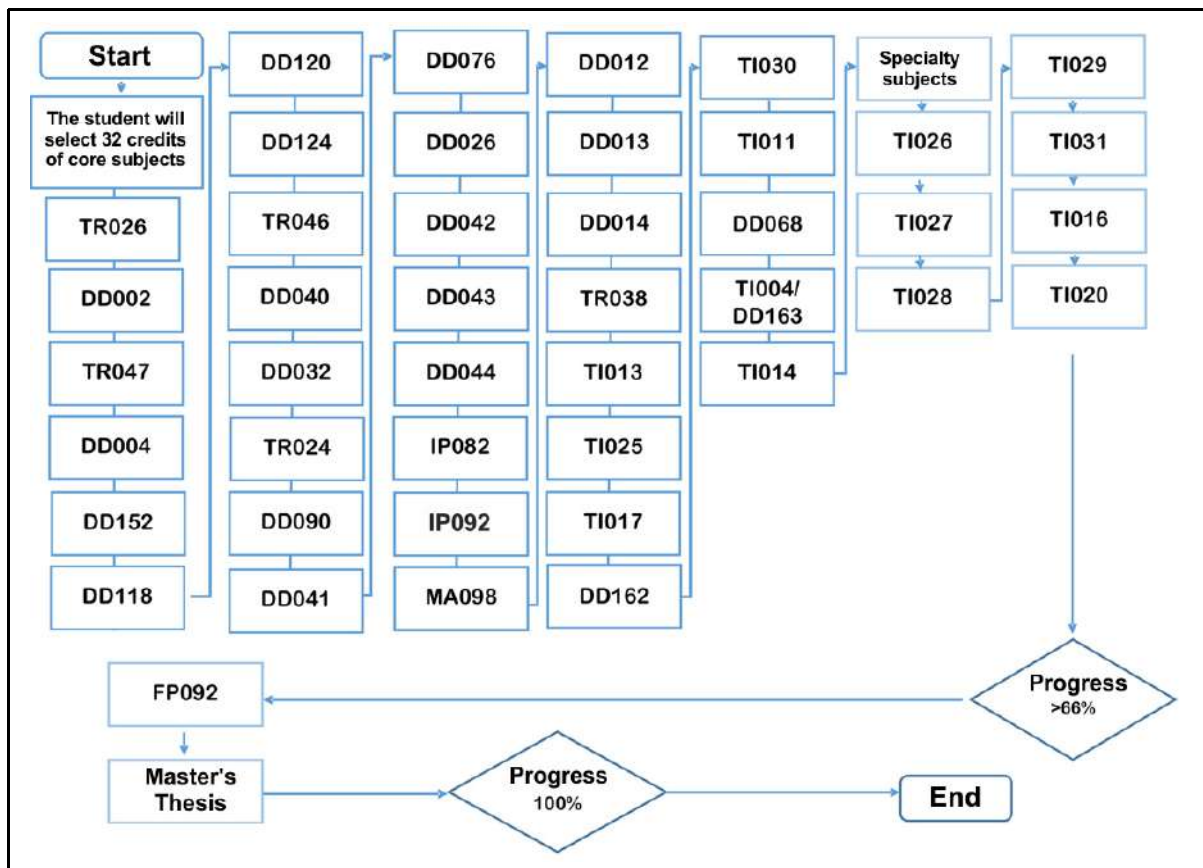


Figura 20: Flow Chart of the Master in Strategic Management Specialty in Telecommunications.

Department of Projects

Doctorate in Projects with a Specialty in Research

UNIVERSIDAD INTERNACIONAL IBEROAMERICANA (UNIB) Doctorate in Projects with a Specialty in Research. (81 CREDITS - 1,215 HOURS) - 5 YEARS AND 3 MONTHS			
Phase I: Introductory courses			
Code	Subject name	Academic Term	Credits
DD070	Introduction to Project Management.	1 month	2
TR038	Project Planning and Scheduling	1 month	2
DD073	Project Control	1 month	2
D0005	Research Methodology 1. Fundamentals.	3 months	6
D00014	Research Methodology II. Paradigms and Methods	1.5 month	3
D0011	Research Seminar (Doctoral Worksheet)	1.5 month	3
Total		9 months	18
Phase II: Modular courses			
Code	Subject name (The student should indicate the subjects they wish to study for this phase. The total number of credits of the chosen subjects should be a minimum of 24 and a maximum of 30)	Academic Term	Credits
DD026	Collaborative Work in Virtual Environments	.5 month	1
DD235	Introduction to the Project Design: from the conflict to the technical problem	1 month	2
DD236	Design of System-Solutions in Projects	1 month	2
DD237	Desired Service and Conditions for Provision	1 month	2
DD238	System Solution: Functional Analysis in the Project	1 month	2
D0012	Cross-Cutting Workshop I	1 month	2
DD239	Roles of People in the Project	1 month	2
DD240	Project Security and Reliability	1 month	2
DD241	Environmental Viability of the Project	1 month	2
D0013	Cross-Cutting Workshop II	1 month	2
DD242	The Project Proposal: Specifications	1 month	2
DD243	Project Draft Preparation	1.5 month	3
Total		1 year	24
Phase III: Research			
Code	Subject name	Academic Term	Credits
D0006	Research Work I	2 months	5
D0007	Research Work II	2 months	5
D000248	Thesis Proposal	8 months	4
Total		1 year	14
Phase IV: Thesis Development			
Code	Subject name	Academic Term	Credits
D0009	Thesis Development	30 months	15
D0010	Thesis Dissertation		10
Total		2.5 years	25

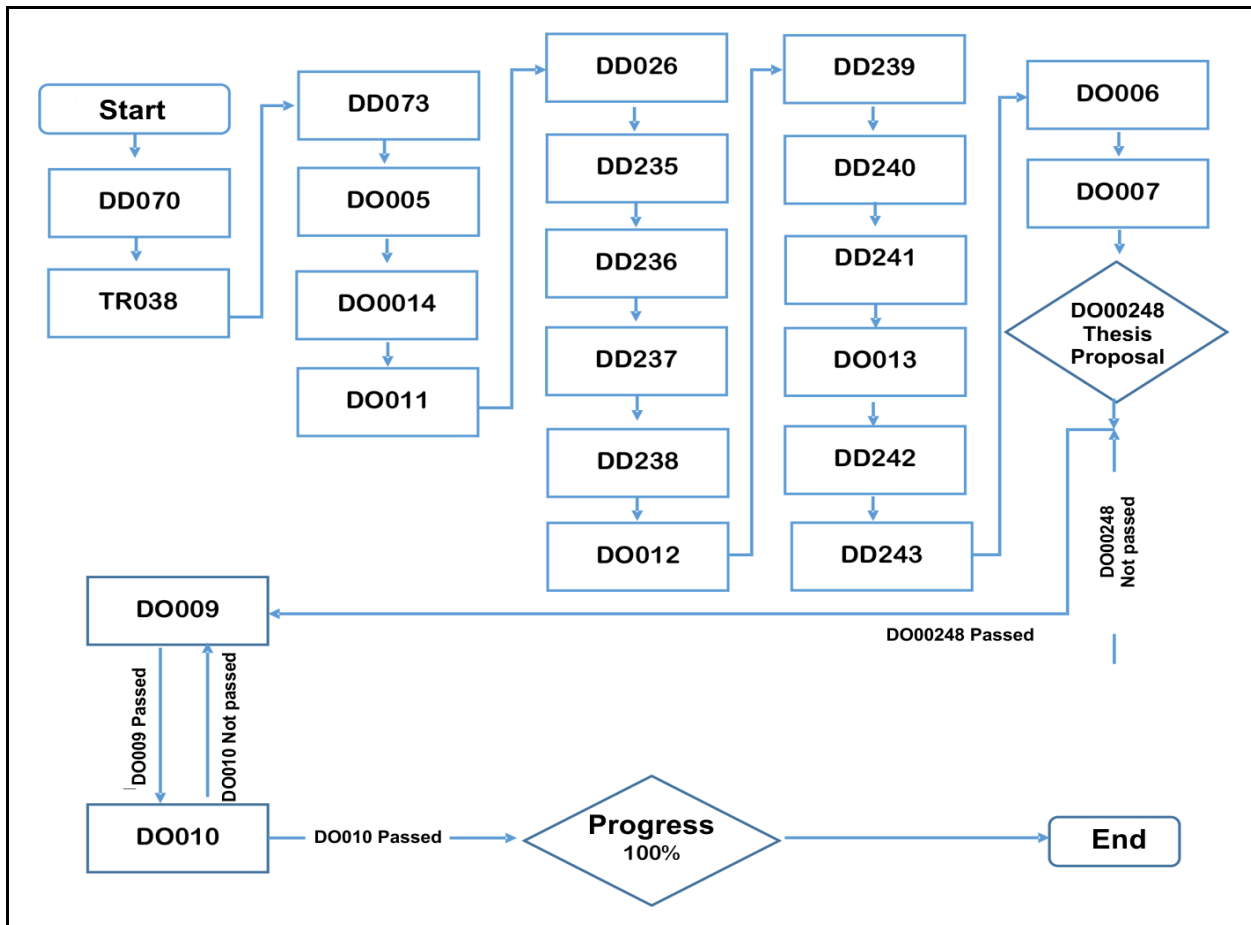


Figura 21: Flow Chart for the Doctorate in Projects with a Specialty in Research.

- All subjects from the doctorates are self-contained, and therefore do not have pre-requisites or co-requisites.
- The sequence of the subjects is determined by the student's work agenda.
- The subjects, following an asynchronous distance model, use the sequence of activities as the central points of the program, but allow the flexibility to move according to the progress of the student. Note that the subjects follow the sequence established in the previous tables, but without impeding the progress of the student.

The charts show the sequence in which the student studies the subjects.

Master in Project Design, Administration and Management

Core subjects: **53 Credits Maximum**

Requirements: **13 credits**

Electives: **14 Credits Maximum**

The student will take a minimum of 66 credits.

	Code	Subject	Pre-requisites	Credits
Core subjects	Project Design			
	DD050	Introduction to Projects	N/A	1
	DD051	Project System Design	N/A	2
	DD052	Analysis of Provision of Services	N/A	2
	DD053	Functional Analysis of the Project	N/A	2
	DD054	Project Ergonomics	N/A	2
	DD055	Project Security and Reliability	N/A	2
	DD056	Environment in a Project	N/A	2
	DD057	Project Specifications	N/A	2
	DD058	Project Draft Preparation	N/A	3
	Project Management			
	DD070	Introduction to Project Management	N/A	1
	TR038	Project Planning and Management	N/A	3
	DD072	Computing Tools for Project Management	N/A	2
	DD073	Project Monitoring and Control	N/A	2
	DD074	Project Evaluation	N/A	2
	DD075	Trust Management: Risk and Quality	N/A	2
	TR046	Strategic Management of Human Resources	N/A	2
	IP092	ISO 45001	N/A	2
	DD077	Project Communication	N/A	1
	Project Administration			
	DD026	Collaborative Work in Virtual Environments	N/A	1
	DD076	Management without Distances	N/A	1
	DD044	Public Speaking Techniques	N/A	1
	TR026	Business Administration and Management	N/A	3
	DD014	Strategic Management and Planning	N/A	3
	DD040	Conflict Resolution and Negotiation Techniques	N/A	2
	DD041	Management Techniques for Teams	N/A	2
	DD068	Knowledge Management and Organizational Learning	N/A	2
	TI025	E-Business and its Integration with Corporate Management Systems	N/A	3

	Code	Subject	Pre-requisites	Credits
Electives	Optative Module: International Cooperation: in the Area of Knowledge Applied to Project Design, Management and Direction			
	PC012	International Collaboration System	N/A	1
	PC013	Logic Framework	N/A	2
	DD090	Business Ethics and Corporate Social Responsibilities	N/A	3
	PC002	Collaboration and Development Theory	N/A	3
	TR047	Financial Management	N/A	3
	DD102	Resolution Transformation of Conflict in the Community	N/A	2
Requirements	Thesis			
	FP092	Methodology of Scientific Research	N/A	3
		Master Thesis/Practicum	N/A	10
TOTAL				66

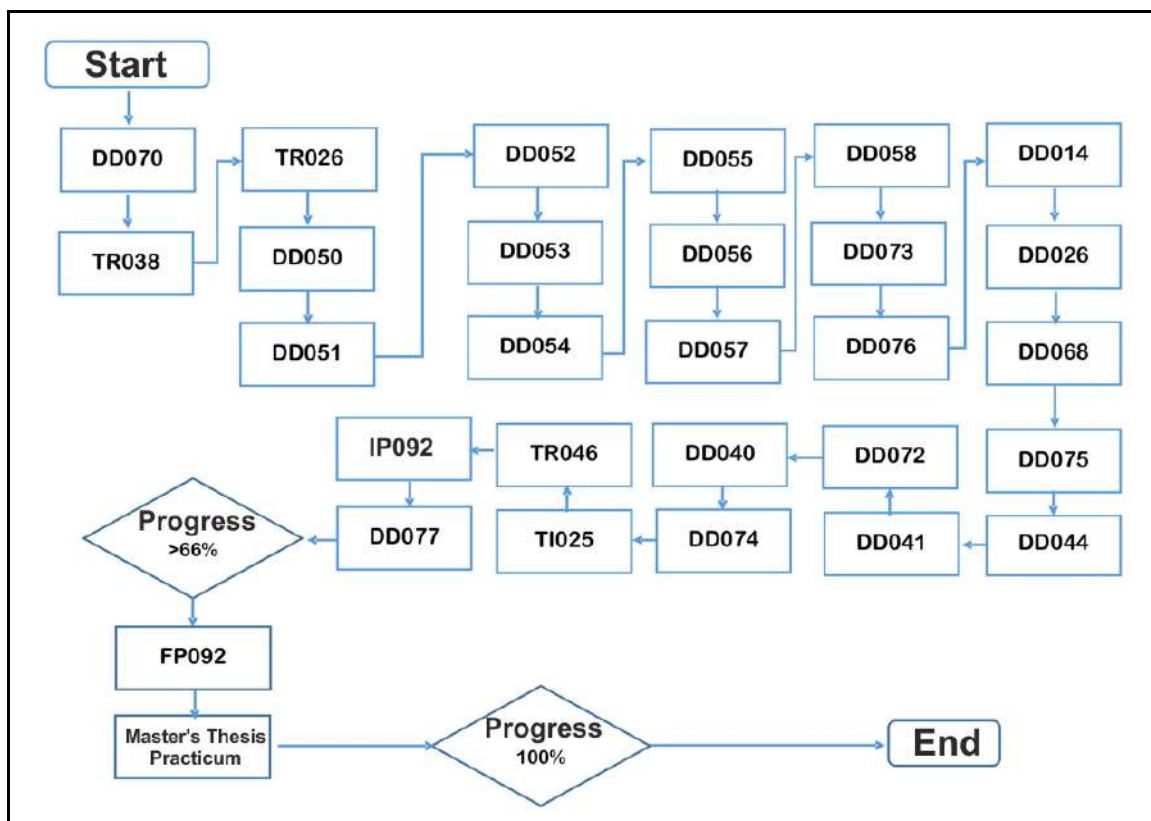


Figura 22: Flow Chart for the Master in Project Design, Administration and Management.

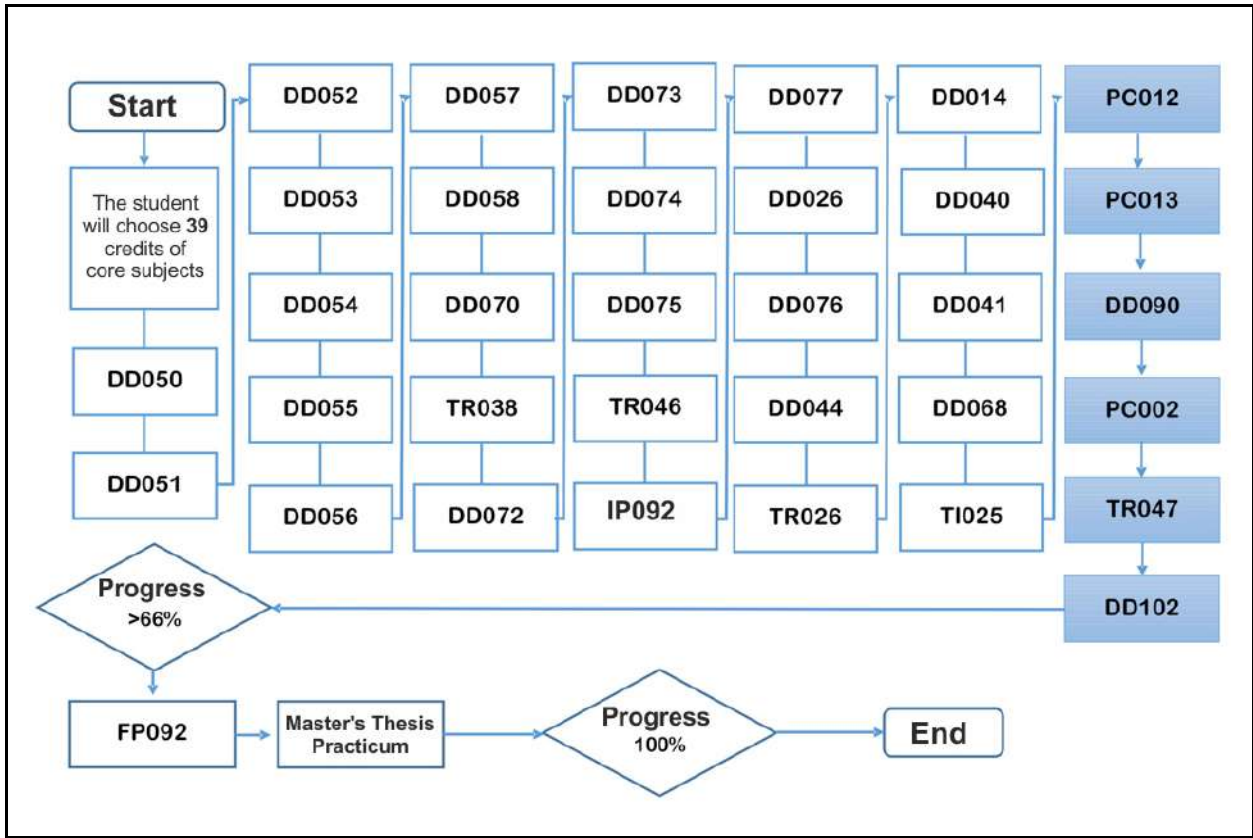


Figura 23: Flow Chart for a curricular schedule for the Master in Project Design, Administration and Management.

Optative Module: International cooperation in the area of applied knowledge to Project Design, Management and Direction⁷.

7. Subjects from the Optative Module are shown in blue.

Master in Project Design, Administration and Management with a Specialty in Architecture and Urban Planning

Core subjects: **18 credits**

Requirements: **49 credits**

The student will take a minimum of 67 credits.

	Code	Subject	Pre-requisites	Credits
Core subjects	Project Design			
	DD050	Introduction to Projects	N/A	1
	DD051	Project System Design	N/A	2
	DD052	Analysis of Provision of Services	N/A	2
	DD053	Functional Analysis of the Project	N/A	2
	DD054	Project Ergonomics	N/A	2
	DD055	Project Security and Reliability	N/A	2
	DD056	Environment in a Project	N/A	2
	DD057	Project Specifications	N/A	2
	DD058	Project Draft Preparation	N/A	3
Requirements	Project Management			
	DD070	Introduction to Project Management	N/A	1
	TR038	Project Planning and Management	N/A	3
	AU001	Architecture and Urbanism Interrelations	N/A	2
	DD073	Project Monitoring and Control	N/A	2
	AU002	The Environment in Urban Planning - Architectural Projects	N/A	2
	DD075	Trust Management: Risk and Quality	N/A	2
	AU003	Technology Impact on Urban Architectural Projects	N/A	2
	AU004	Contextual Components of the Project: Economic, Social, Institutional and Cultural	N/A	2
	AU005	City Marketing	N/A	2
	Project Administration			
	AU006	Architectural-Urban Project Theory	N/A	1
	DD076	Management without Distances	N/A	1
	DD044	Public Speaking Techniques	N/A	1
	TR026	Business Administration and Management	N/A	3
	DD014	Strategic Management and Planning	N/A	3
	AU007	Preservation of the Architectural Urban Heritage	N/A	2
	DD041	Management Techniques for Teams	N/A	2
DD068	Knowledge Management and Organizational Learning	N/A	2	
AU008	The Function of the State	N/A	3	
Requirements	Thesis			
	FP092	Methodology of Scientific Research	N/A	3
		Master Thesis/Practicum	N/A	10
TOTAL				67

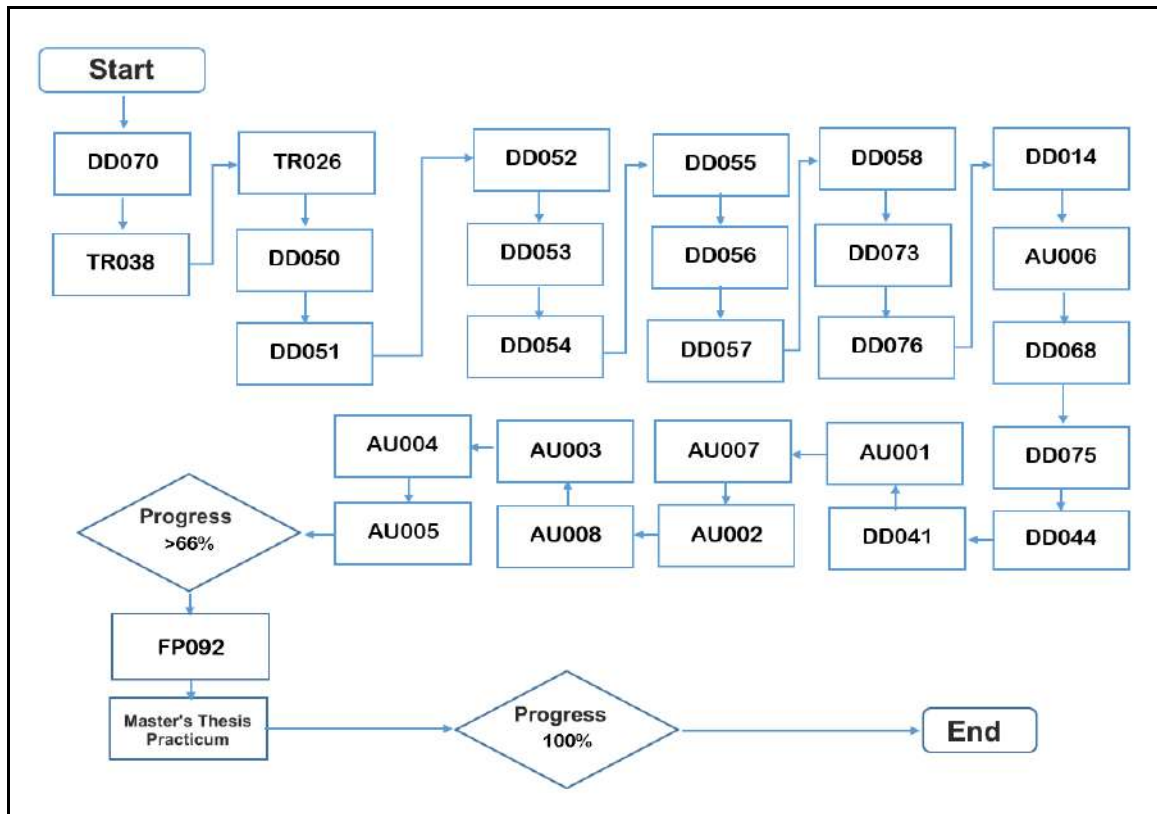


Figura 24: Flow Chart for the Master in Project Design, Administration and Management. with a Specialty in Architecture and Urban Planning.

Master in Project Design, Administration and Management with a Specialty in Innovation and Product

Core subjects: **18 credits**

Requirements: **48 credits**

The student will take a minimum of 66 credits.

	Code	Subject	Pre-requisites	Credits
Core subjects	Project Design			
	DD050	Introduction to Projects	N/A	1
	DD051	Project System Design	N/A	2
	DD052	Analysis of Provision of Services	N/A	2
	DD053	Functional Analysis of the Project	N/A	2
	DD054	Project Ergonomics	N/A	2
	DD055	Project Security and Reliability	N/A	2
	DD056	Environment in a Project	N/A	2
	DD057	Project Specifications	N/A	2
	DD058	Project Draft Preparation	N/A	3
Requirements	Project Management			
	DD070	Introduction to Project Management	N/A	1
	TR038	Project Planning and Management	N/A	3
	AU010	Integral Management of Design and Product	N/A	2
	DD073	Project Monitoring and Control	N/A	2
	AU011	Areas of Design Contextual Conditions and User Requirements	N/A	2
	DD075	Trust Management: Risk and Quality	N/A	2
	AU012	Innovation as a Tool for Improvement and Product Value Contribution	N/A	2
	AU013	Product and Environment	N/A	2
	DD077	Project Communication	N/A	1
	Project Administration			
	AU014	Object Theory	N/A	1
	DD076	Management without Distances	N/A	1
	DD044	Public Speaking Techniques	N/A	1
	TR026	Business Administration and Management	N/A	3
	DD014	Strategic Management and Planning	N/A	3
	AU015	Relations between Innovation, Creativity, Productivity, and Competitiveness	N/A	2
	AU016	Product Design and the Agents of Technology Innovation	N/A	2
	DD068	Knowledge Management and Organizational Learning	N/A	2
AU017	Profit and Strategic Design	N/A	3	
Requirements	Thesis			
	FP092	Methodology of Scientific Research	N/A	3
		Master Thesis/Practicum	N/A	10
TOTAL				66

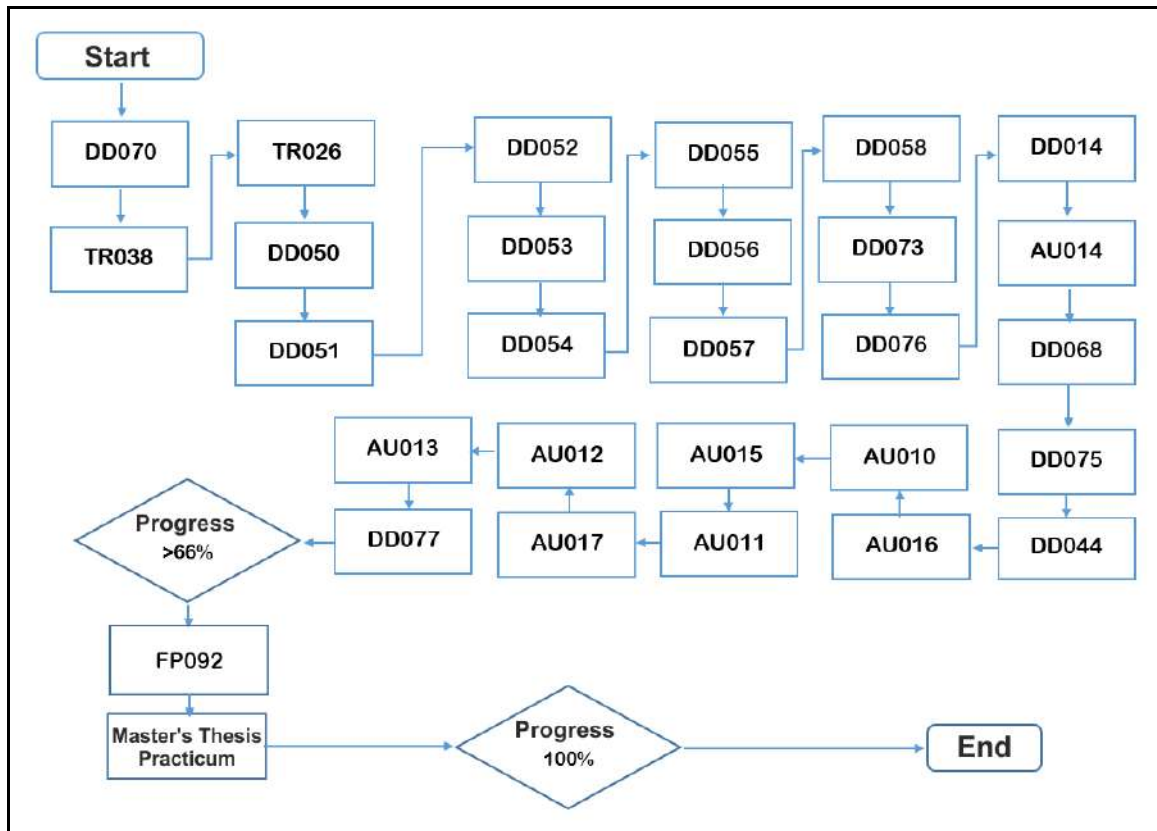


Figura 25: Flow Chart for the Master in Project Design, Administration and Management. with a Specialty in Innovation and Product.

Department of Environment and Sustainability

Master in Environmental Management and Auditing

Core subjects: **46 Credits Maximum**

Requirements: **13 credits**

Electives: **7 minimum credits**

The student will take a minimum of 66 credits.

	Code	Subject	Pre-requisites	Credits
Core subjects	MA001	Introduction to Sustainable Development	N/A	2
	MA002	Ecology	N/A	1
	MA003	Water Treatment	N/A	4
	MA004	Waste Management	N/A	4
	MA005	Air Pollution	N/A	3
	MA006	Climatology and the Environment	N/A	1
	MA007	Noise pollution	N/A	1
	MA008	Natural Resources	N/A	3
	MA009	Land Pollution	N/A	3
	MA010	Business Environmental Management	N/A	4
	MA011	Environmental Audits	N/A	2
	MA012	Environmental Impact Assessment	N/A	3
	MA013	Economy and the Environment	N/A	1
	MA014	Environmental Law	N/A	1
	MA092	Fundamentals of Environmental Engineering	N/A	7
	MA316	Dynamic Earth	N/A	2
	MA317	Coastline and Marine Erosion	N/A	2
	MA318	Marine Sediments and Glacial Influence of the Seas	N/A	2
	MA019	Facilities and Sewage Purification Treatments	N/A	7
	MA108	Fishery Exploitation	N/A	2
	MA109	Marine Cultures	N/A	2
	MA110	Navigation and Marine Transportation	N/A	2
	MA111	Mineral and Energy Resources	N/A	2
	MA102	Basic Marine Ecology	N/A	1
	MA103	Marine Organisms	N/A	2
	MA104	Marine Communities	N/A	3
	MA105	Sea Water	N/A	2
	MA106	Water Circulation	N/A	2
	MA107	Sea Water Chemistry	N/A	2
	MA098	Business Environmental Management ISO 14001	N/A	7

	Code	Subject	Pre-requisites	Credits
Electives	Optative Module: Comprehensive Water Management			
	MA015	Introduction to Project Management:	N/A	2
	MA016	The Water Cycle	N/A	2
	MA017	Water Management	N/A	3
	MA018	Water Analysis and Characterization	N/A	3
	MA021	Water and Environmental Education	N/A	0
	MA209	Facilities and Water Treatment	N/A	10
	Optative Module: Waste Management			
	MA081	MA081-Urban Solid Waste	N/A	7
	MA082	Industrial Waste	N/A	6
	MA083	Rural Waste	N/A	3
	MA084	Sanitary Waste	N/A	4
	MA085	Environment Education and the MSW	N/A	0
	Optative Module: Renewable Energy Application			
	MA057	Introduction to Renewable Energies	N/A	3
	MA059	Solar Thermal Energy	N/A	3
	MA060	Photovoltaic Solar Energy	N/A	3
	MA061	Hydraulic Energy	N/A	3
	MA062	Wind Energy	N/A	3
	MA063	Geothermal Energy	N/A	1
	MA064	Biomass Energy	N/A	2
	MA065	Sea Energy	N/A	2
	Optative Module: Management and Conservation of Natural Spaces			
	MA073	Natural Areas in the Context of Societies.	N/A	2
	MA074	Biodiversity	N/A	3
	MA075	Natural Spaces: Typology and Processes	N/A	3
	MA076	Uses of Natural Spaces	N/A	3
	MA077	The Conservation of Species and Natural Areas	N/A	3
	MA078	Management of Natural Spaces	N/A	4
	MA079	Ecological Restoration and Landscaping	N/A	2
	MA080	Case studies of Management and Conservation of Natural Spaces	N/A	0
	Optative Module: Environmental Education			
	MA087	Evolution of the Environment and Sustainable Development	N/A	2
	MA088	Historical Evolution of Environmental Education	N/A	2
	MA194	Basic General Concepts of Environmental Education	N/A	2
	MA195	Environmental Education in Formal Education	N/A	3
	MA090	Environmental Management and Sustainable Development	N/A	2
	MA091	Risk Management and Environmental Education	N/A	2
	Optative Module: Marine Sciences and Technologies			
	MA243	Management of Water Pollutants	N/A	4
	MA136	Marine Aquaculture Technology: Toward a Sustainable Aquaculture	N/A	3
	MA140	Fisheries Management	N/A	3
	MA139	Management of Natural Marine Protected Areas	N/A	3
MA137	Biological Pollution Management	N/A	4	
MA098	Business Environmental Management ISO 14001	N/A	7	

	Code	Subject	Pre-requisites	Credits
Electives	Optative Module: Marine Contamination.			
	MA028	Potentially Contaminated Marine Ecosystems	N/A	2
	MA029	Environmental Factors that Affect Pollutants	N/A	2
	MA030	Pollutants	N/A	2
	MA031	Toxicology	N/A	1
	Optative Module: Environmental Engineering: Treatment of Gaseous Effluents			
	MA095	Treatment of Gaseous Effluents	N/A	7
	Optative Module: Environmental Engineering: Energy Recovery			
	MA143	Energy Recovery	N/A	7
	Optative Module: Environmental Engineering: Industrial Wastewater Treatment			
	MA039	Industrial Wastewater Treatment	N/A	13
	Optative Module: Environmental Engineering: Solid Waste Treatment			
	MA093	Engineering Recovery and Treatment of Waste	N/A	13
	Optative Module: Recovery of Contaminated Soils			
	MA142	Recovery of Contaminated Soils	N/A	7
	Optative Module: Mining and the Environment			
	MA208	Mining and the Environment	N/A	13
	Optative Module: Climate Change			
	MA245	Agreements, Negotiations and Instruments for Climate Change	N/A	8
	MA246	Vulnerability and Adaptation to Climate Change	N/A	9
	MA248	Science and Politics of Climate Change	N/A	7
	MA249	Analysis of Product Lifecycle and Carbon Footprint	N/A	3
	MA282	Climate Change Mitigation	N/A	8
	Optative Module: Environmental Technology and Engineering			
	MA093	Engineering Recovery and Treatment of Waste	N/A	13
	MA039	Industrial Wastewater Treatment	N/A	13
MA095	Treatment of Gaseous Effluents	N/A	7	
MA143	Energy Recovery	N/A	7	
MA097	Recovery of Contaminated Soils	N/A	7	
Requirements	Master's Thesis			
	FP092	Methodology of Scientific Research	N/A	3
		Master Thesis	N/A	10
TOTAL				66

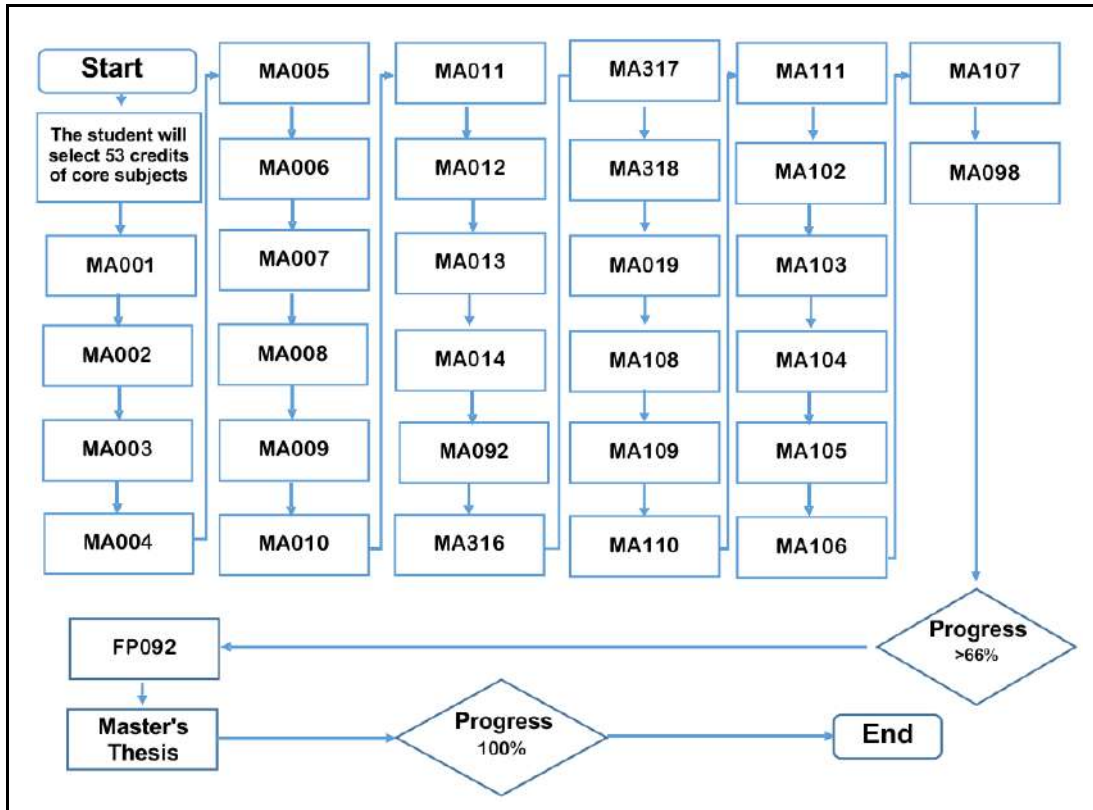


Figura 26: Flow Chart of the Master in Environmental Management and Auditing.

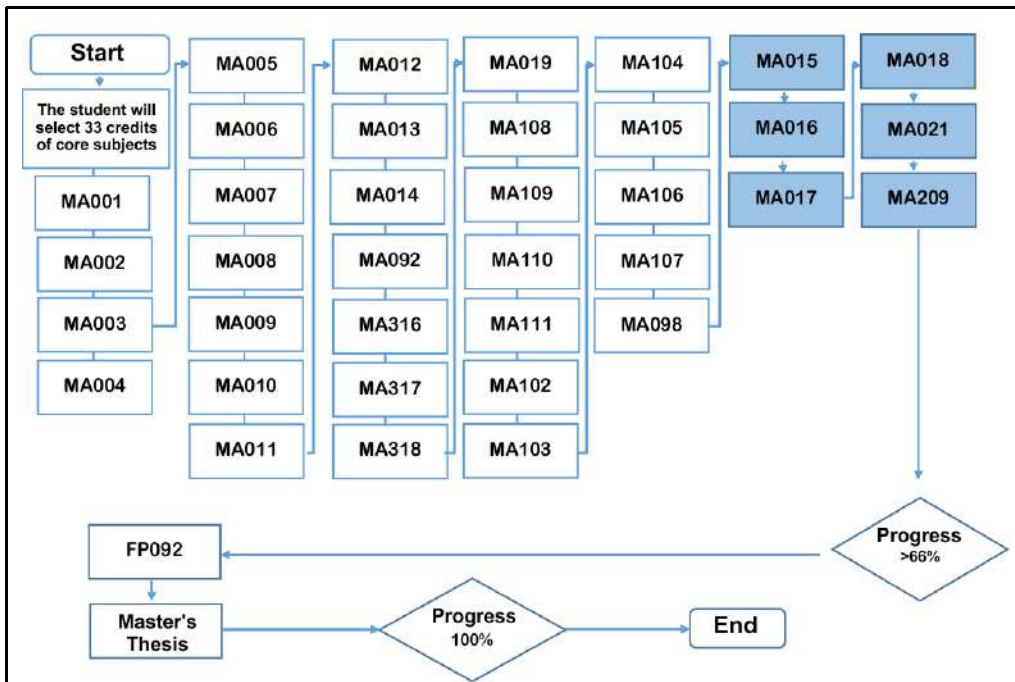


Figura 27: Flow Chart of the Master in Environmental Management and Auditing. Optative Module: Comprehensive Water Management⁸.

8. Subjects from the Optative Module are shown in blue.

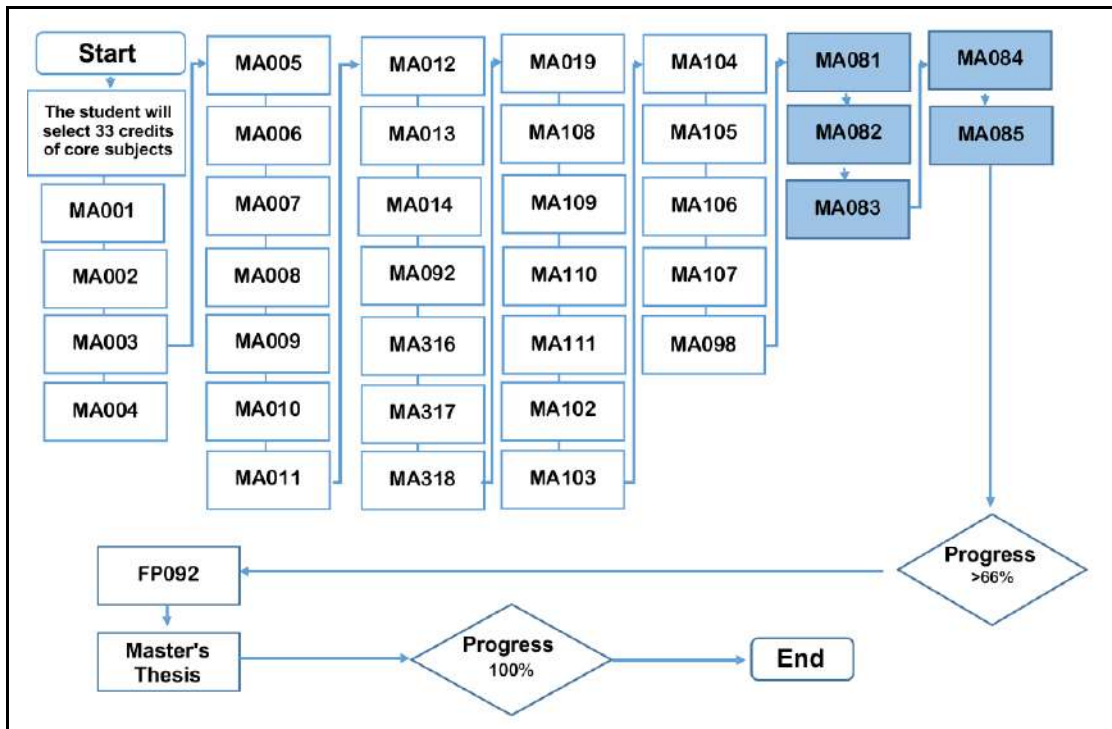


Figura 28: Flow Chart of the Master in Environmental Management and Auditing. Optative Module: Waste Management⁹.

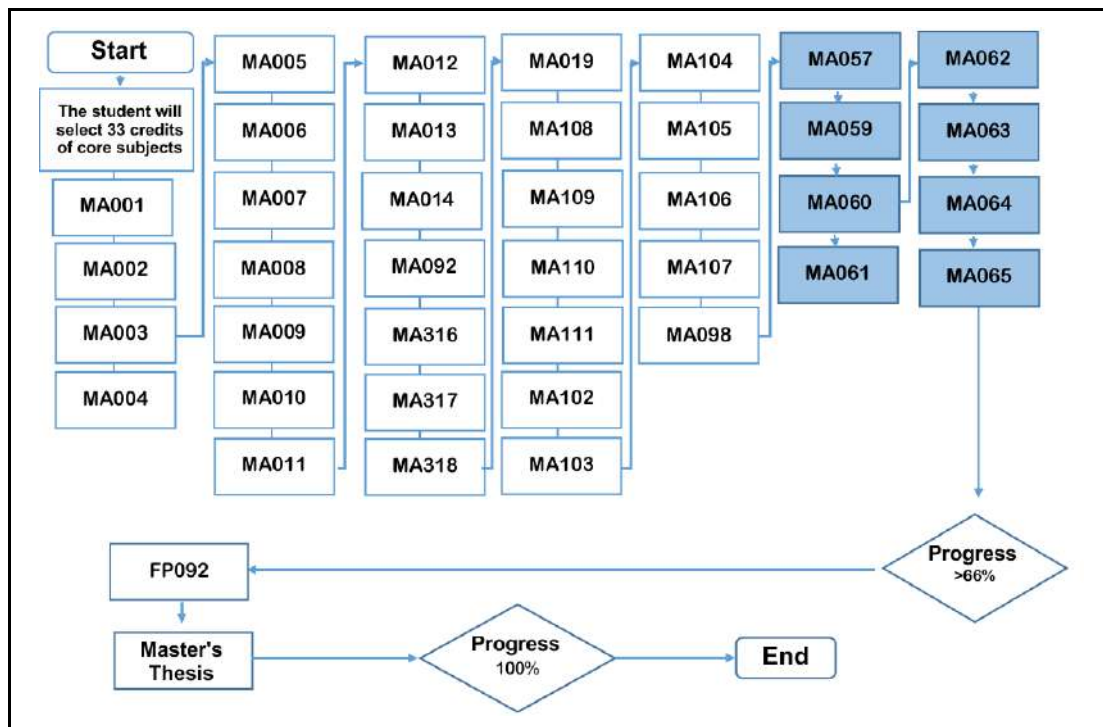


Figura 29: Flow Chart of the Master in Environmental Management and Auditing. Optative Module: Renewable Energy Application⁹.

9. Subjects from the Optative Module are shown in blue.

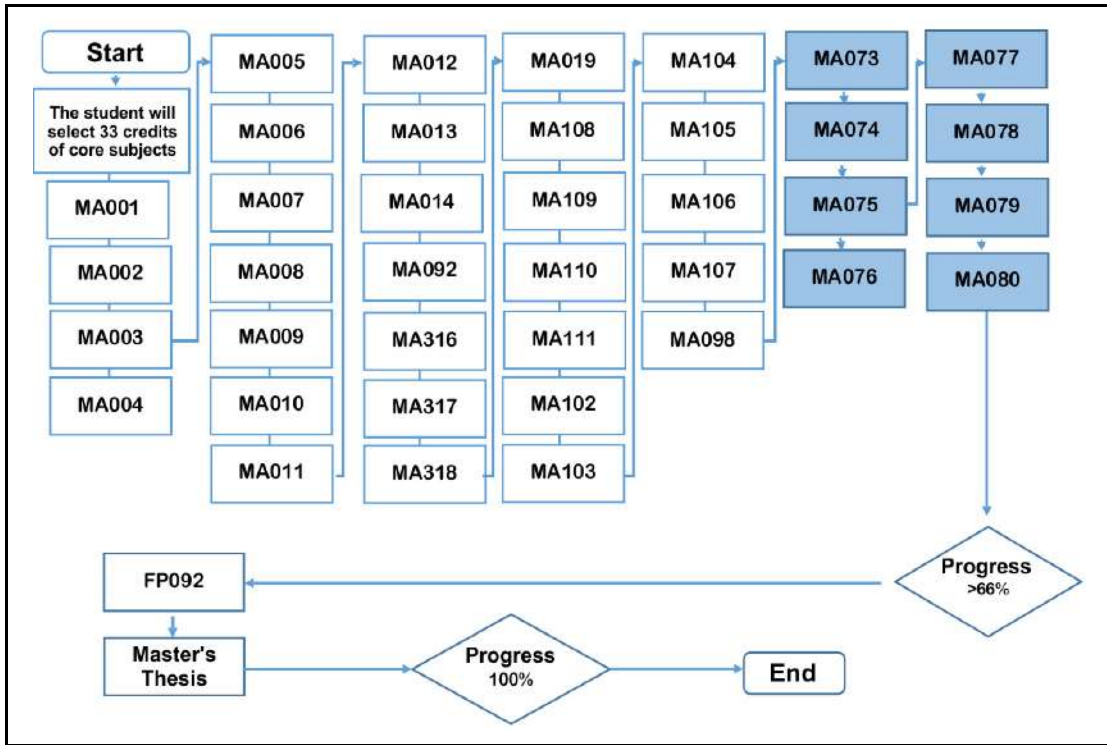


Figura 30: Flow Chart of the Master in Environmental Management and Auditing. Optative Module: Management and Conservation of Natural Spaces¹⁰.

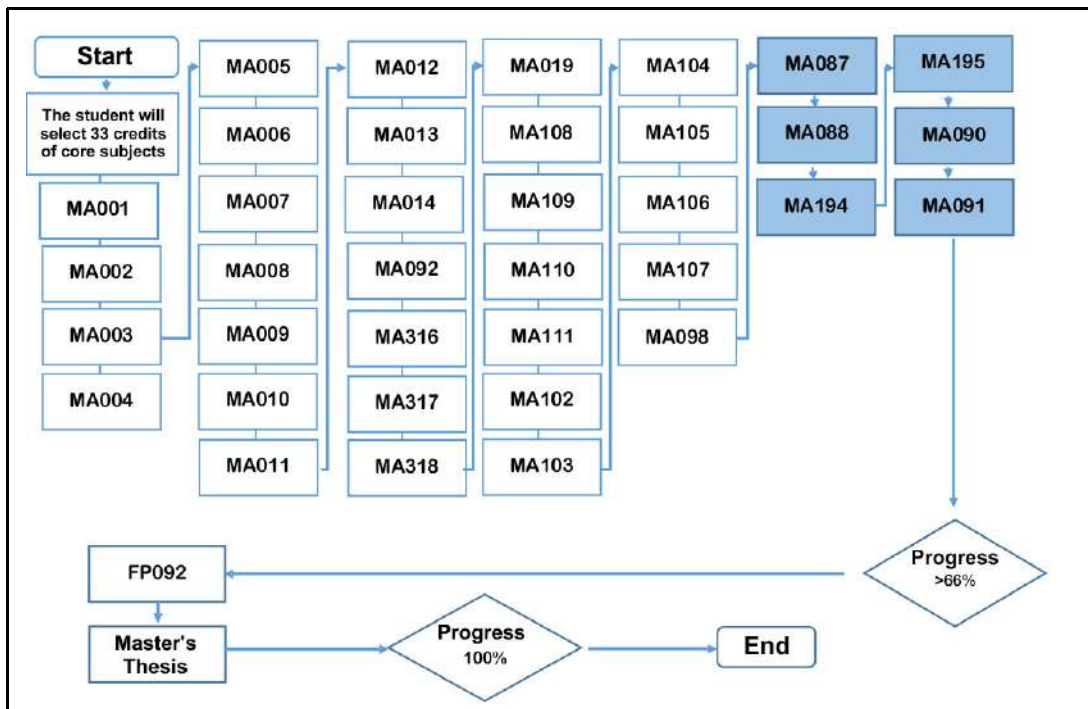


Figura 31: Flow Chart of the Master in Environmental Management and Auditing. Optative Module: Environmental Education¹⁰.

10. Subjects from the Optative Module are shown in blue.

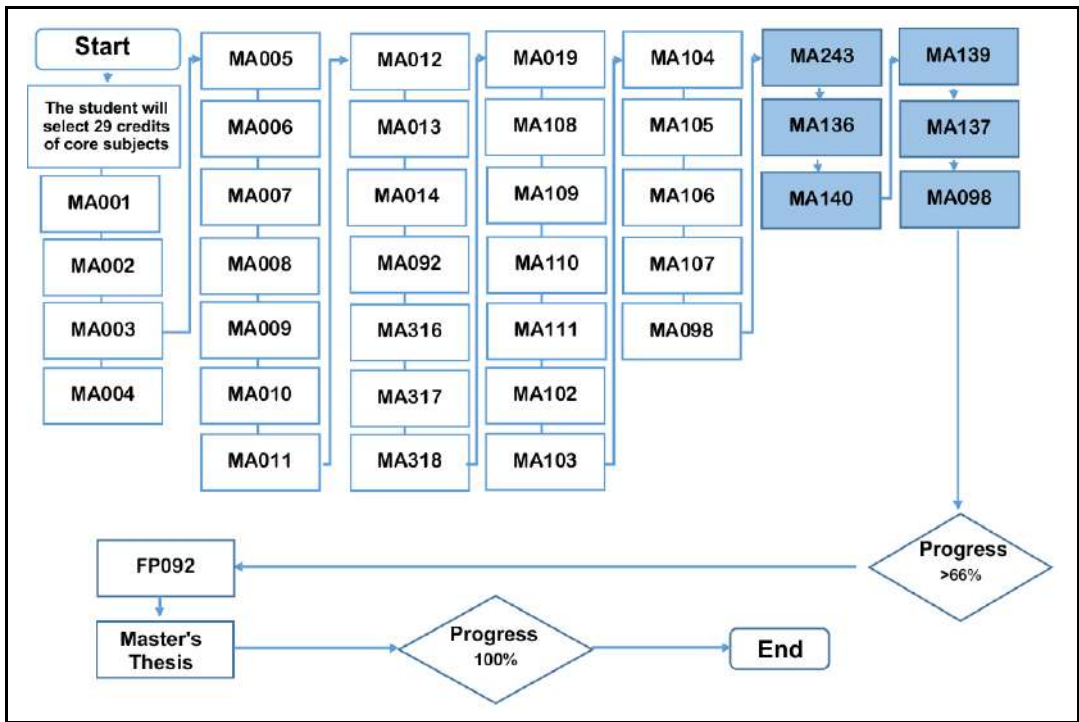


Figura 32: Flow Chart of the Master in Environmental Management and Auditing. Optative Module: Marine Sciences and Technologies¹¹.

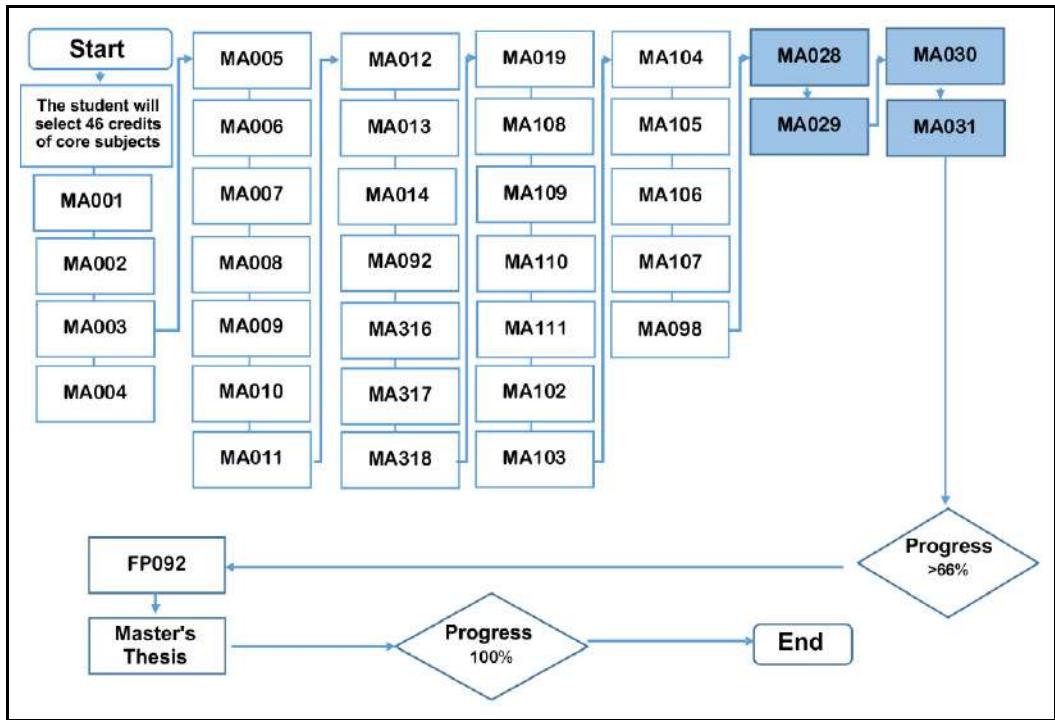


Figura 33: Flow Chart of the Master in Environmental Management and Auditing. Optative Module: Marine Contamination¹¹.

11. Subjects from the Optative Module are shown in blue.

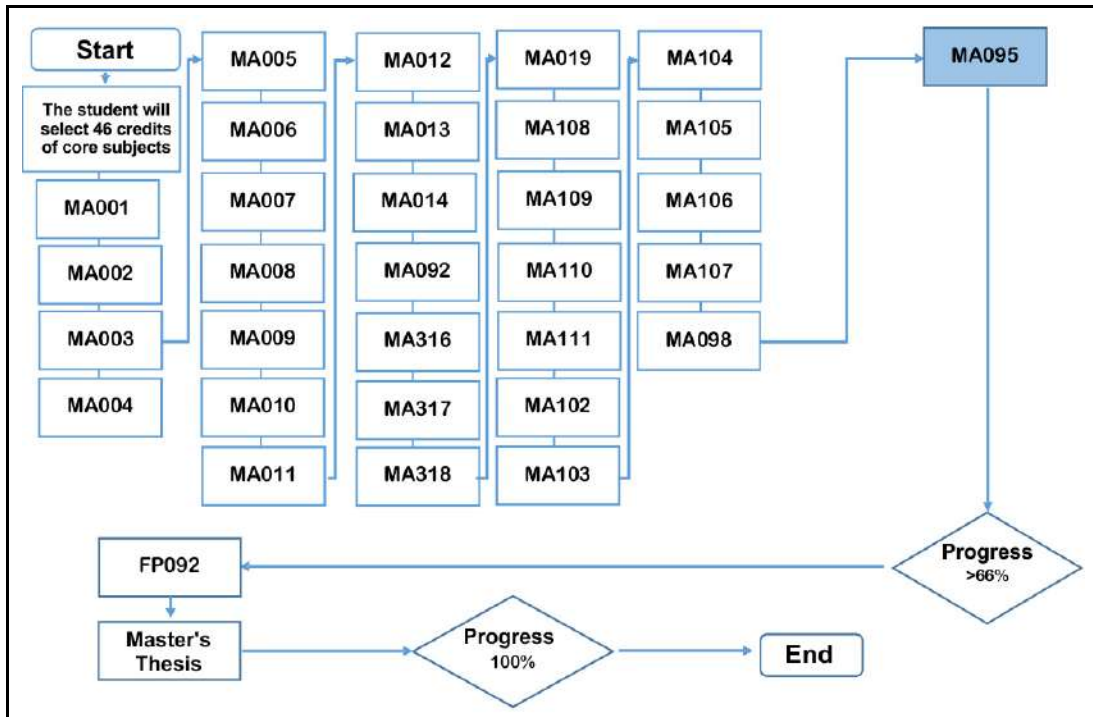


Figura 34: Flow Chart of the Master in Environmental Management and Auditing. Optative Module: Environmental Engineering: Treatment of Gaseous Effluents¹².

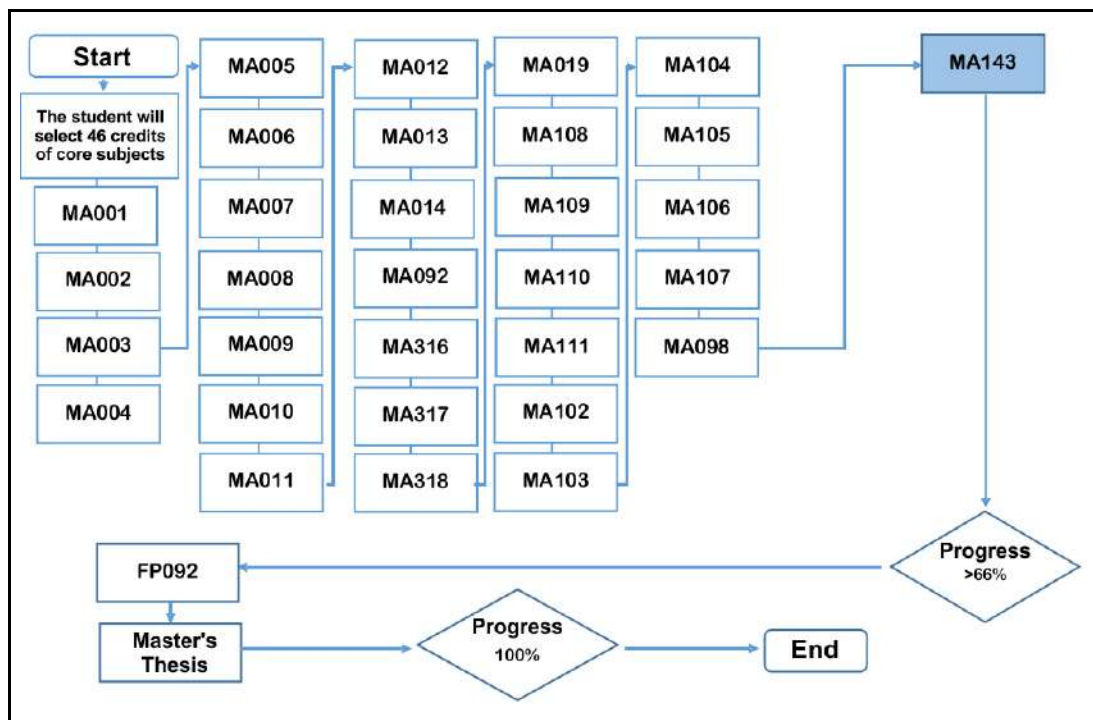


Figura 35: Flow Chart of the Master in Environmental Management and Auditing. Optative Module: Energy Recovery¹².

12. Subjects from the Optative Module are shown in blue.

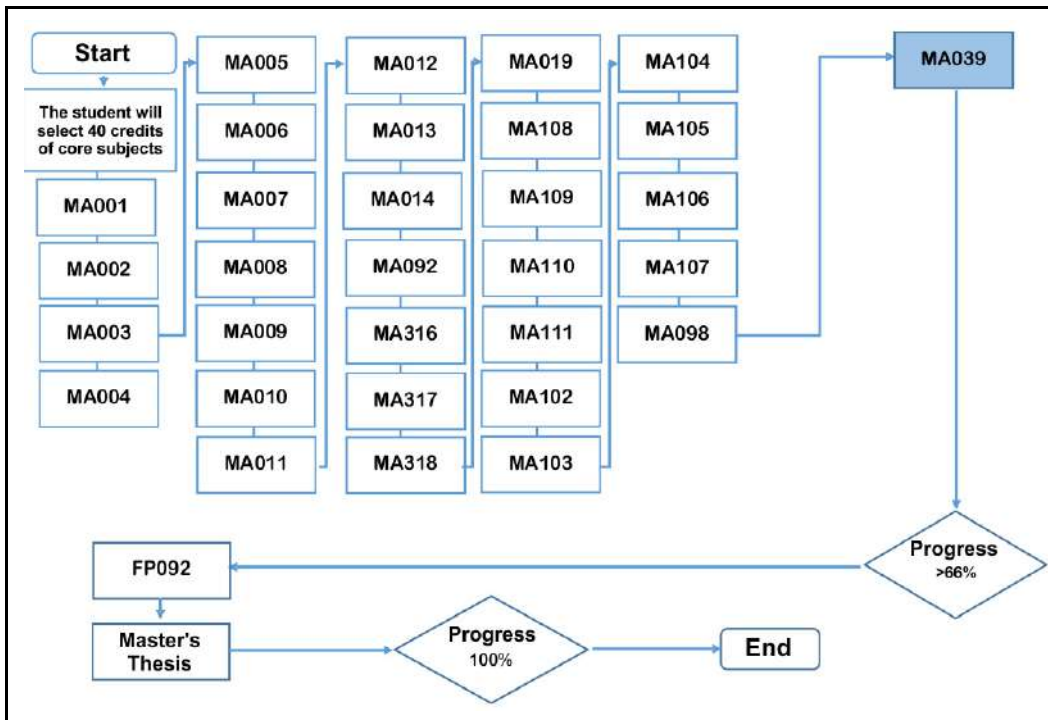


Figura 36: Flow Chart of the Master in Environmental Management and Auditing. Optative Module: Environmental Engineering: Industrial wastewater treatment¹³.

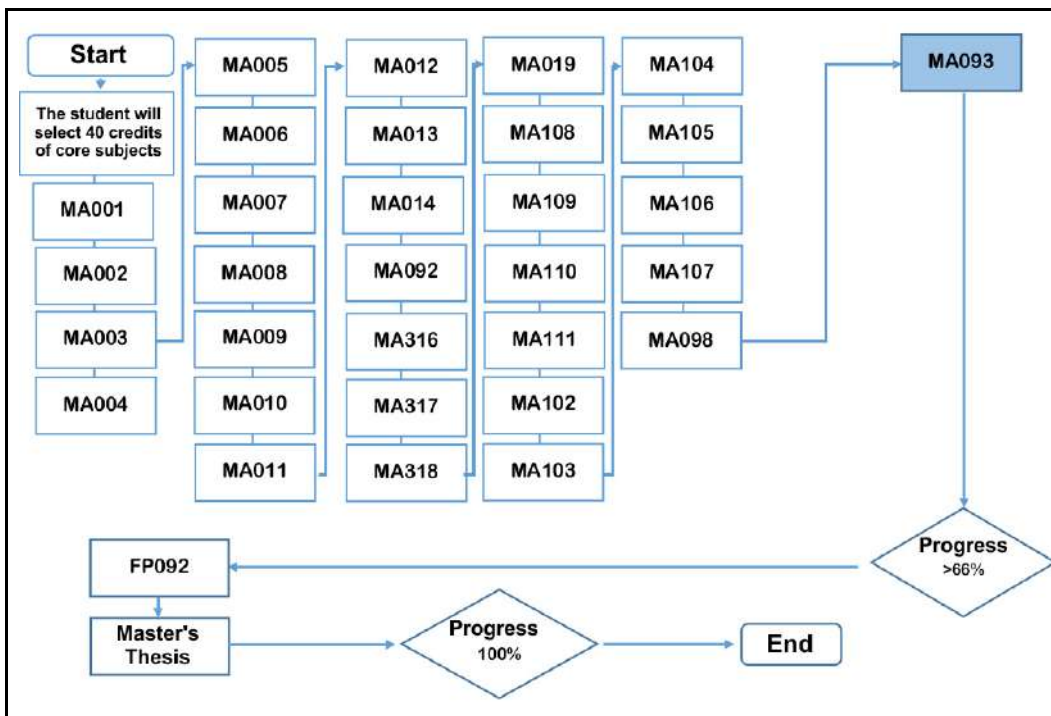


Figura 37: Flow Chart of the Master in Environmental Management and Auditing. Optative Module: Environmental Engineering: Solid Waste Treatment¹³.

13. Subjects from the Optative Module are shown in blue.

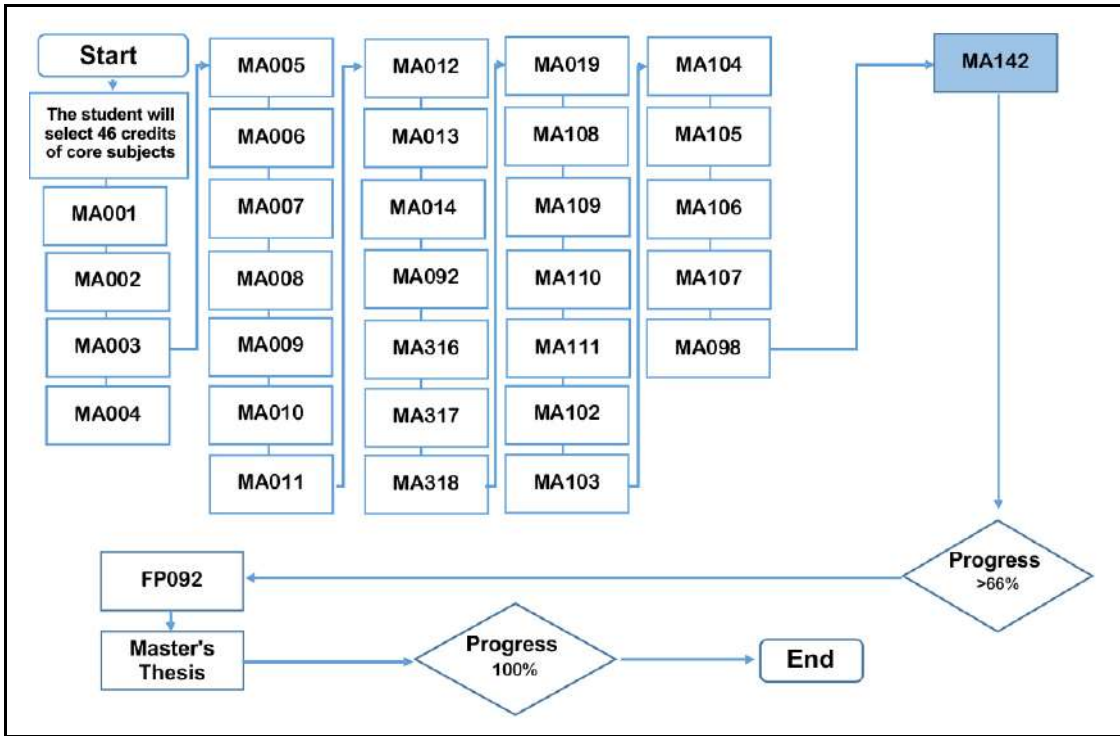


Figura 38: Flow Chart of the Master in Environmental Management and Auditing. Optative Module: Recovery of Contaminated Soils¹⁴.

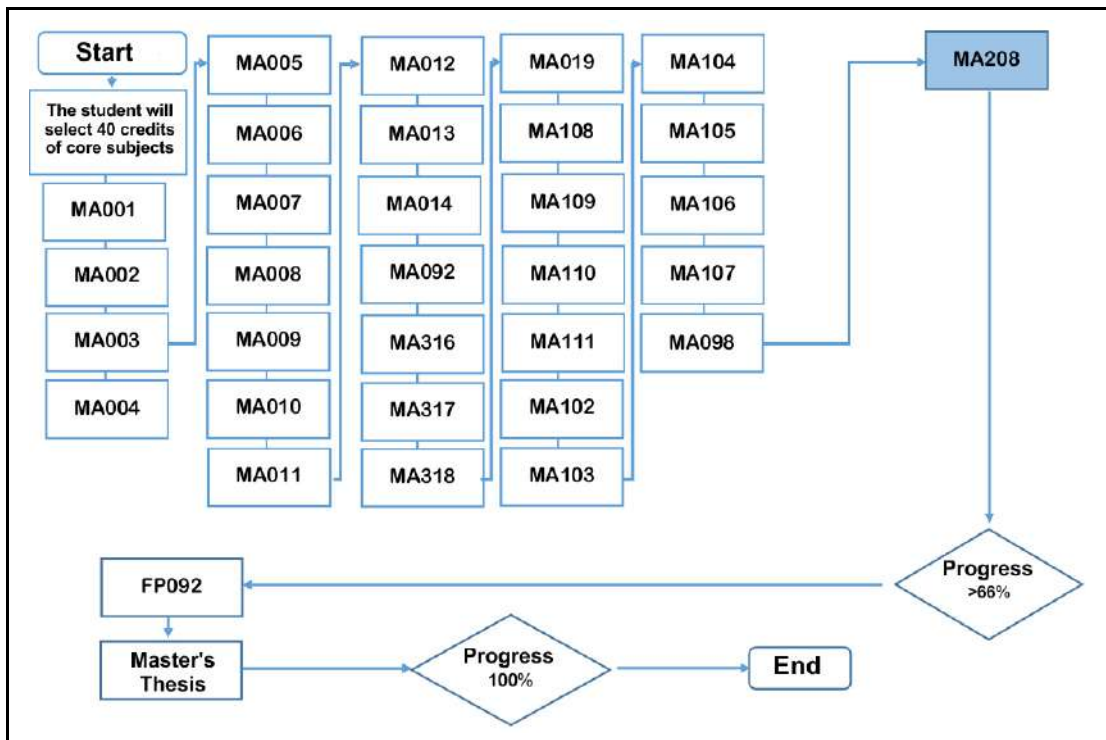


Figura 39: Flow Chart of the Master in Environmental Management and Auditing. Optative Module: Mining and the Environment¹⁴.

14. Subjects from the Optative Module are shown in blue.

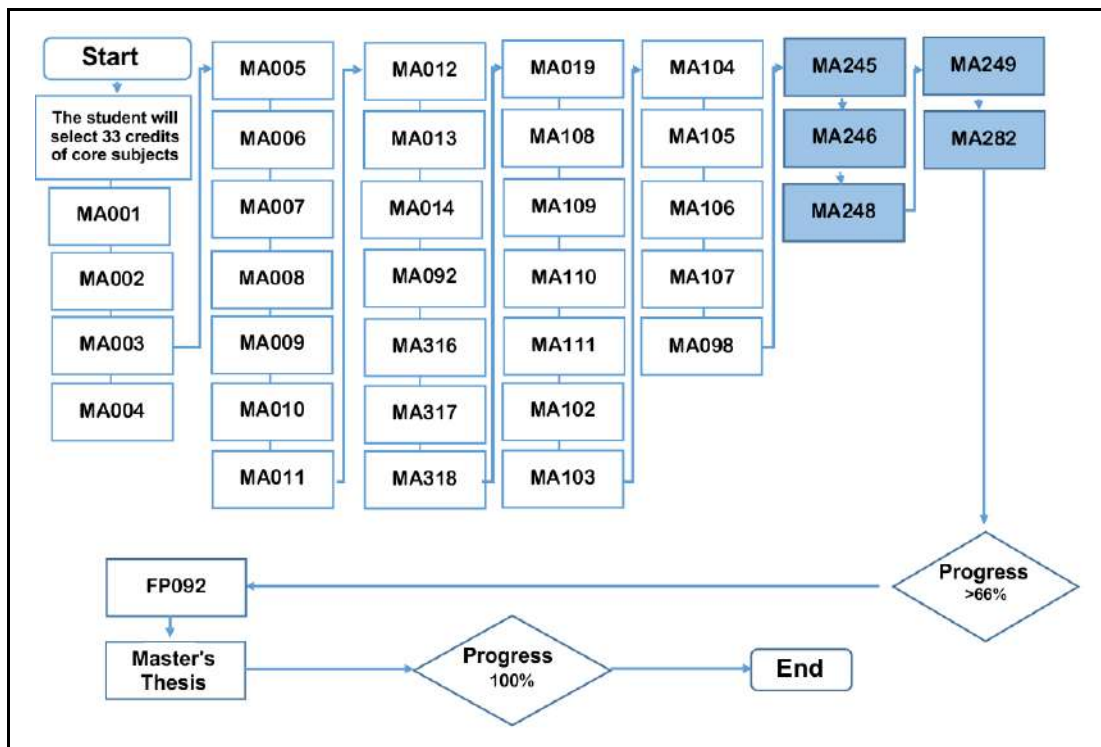


Figura 40: Flow Chart of the Master in Environmental Management and Auditing. Optative Module: Climate Change¹⁵.

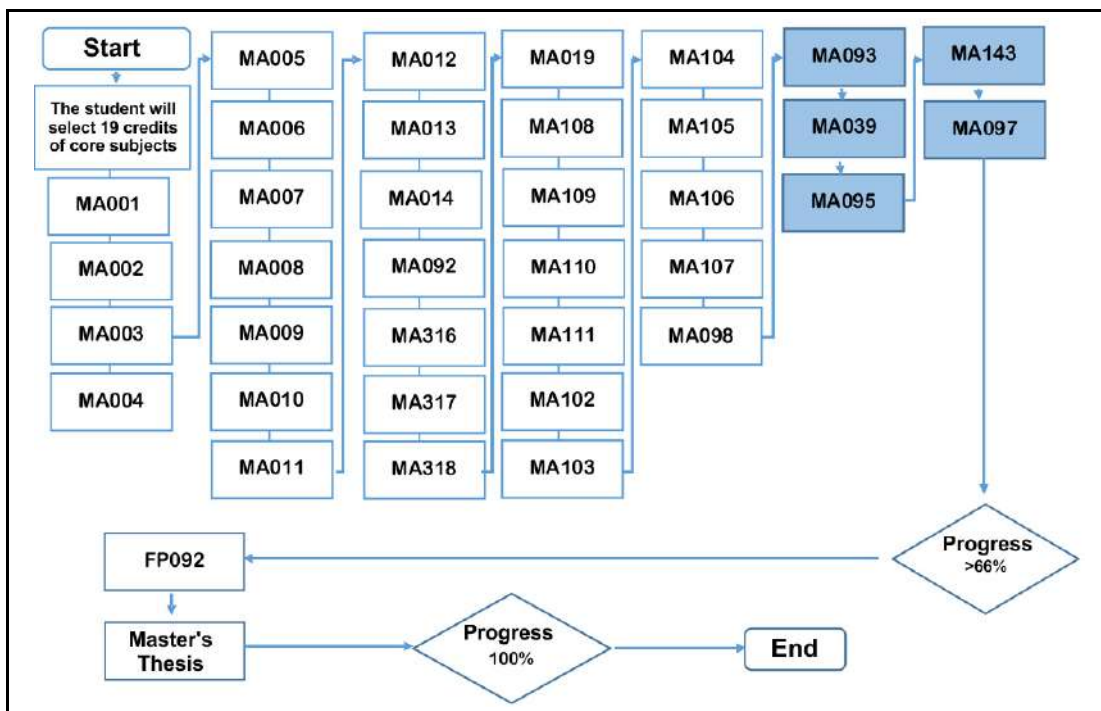


Figura 41: Flow Chart of the Master in Environmental Management and Auditing. Optative Module: Environmental Technology and Engineering¹⁵.

15. Subjects from the Optative Module are shown in blue.

Department of Health Sciences

Master in Physical Activity: Sports Training and Management

Core subjects: **24 credits**

Requirements: **13 credits**

Electives: **29 credits**

The student will take a minimum of 66 credits.

	Code	Subject	Pre-requisites	Credits
Core subjects	SN039	Structure and Function of the Human Body	N/A	3
	SN155	Understanding Physical Activity and Exercise within the Framework of Health	N/A	3
	SN156	Psychosocial Aspects of Physical Activity for Health	N/A	4
	SN157	Control and Prescription of Physical Activity	N/A	3
	SN158	Physical Activity for Health with Diverse Diseases	N/A	4
	SN159	Physical Activity in Children and Adolescents	N/A	3
	SN160	Physical activity in seniors	N/A	4
Electives	Optative Module: Sports Training			
	SN198	Basic Aspects of Nutrition	N/A	0
	SN048	Training Theory and Practice	N/A	4
	SN049	Sports Planning	N/A	4
	SN050	Sport Psychology	N/A	3
	SN042	Kinanthropometry	N/A	3
	SN217	Nutrition and Sport	SN198	3
	SN047	Eating Disorders in Sports	N/A	3
	SN043	Ergogenic Aids	N/A	3
	DP004	Management Techniques for Sports Teams	N/A	2
	SN228	Study and Case Resolution for Sports Training	N/A	4
	Optative Module: Management and Abilities for the Operation of Sports Centers			
	DP001	Administration and Management of Sport Entities	N/A	3
	DP002	Strategic Management and Planning of Sport Organizations	N/A	3
	DP003	Sports Marketing. Applications	N/A	3
	DD1021	Strategic Management of Human Resources	N/A	2
	DP004	Management Techniques for Sports Teams	N/A	2
	DP006	Techniques for Management and Leadership in Sports	N/A	2
	DP007	Society of Change and Information	N/A	3
	SN048	Training Theory and Practice	N/A	4
	SN042	Kinanthropometry	N/A	3
	SN229	Study and Case Resolution for Sports Skills	N/A	4
Requirements	Thesis			
	FP092	Methodology of Scientific Research	N/A	3
		Master Thesis/Practicum	N/A	10
TOTAL				66

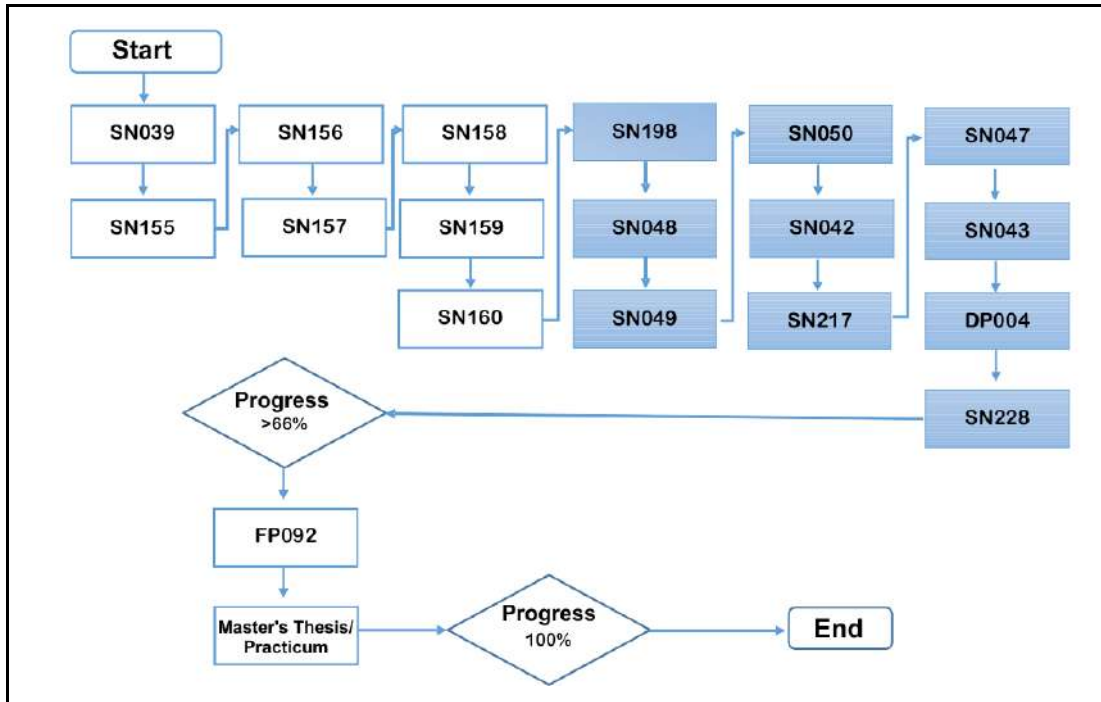


Figura 42: Flow Chart of the Master in Physical Activity: Sports Training and Management. Optative Module: Sports Training¹⁶.

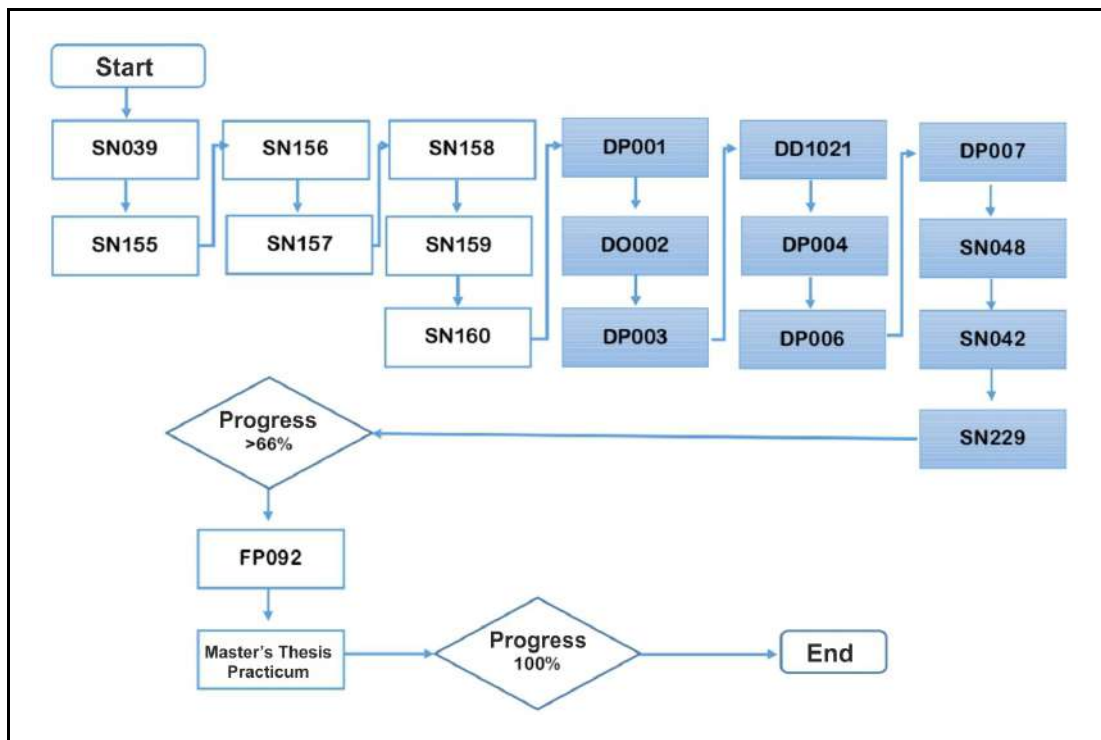


Figura 43: Flow Chart of the Master in Physical Activity: Sports Training and Management. Optative Module: Management and Abilities for the Operation of Sports Centers¹⁶.

16. Subjects from the Optative Module are shown in blue.

Master in Naturopathic Sciences

General Education: **36 credits**

Core subjects: **18 credits**

Requirements: **25 credits**

Electives: **15 credits**

The student will take a minimum of 94 credits.

	Code	Subject	Pre-requisites	Credits
General Education:	Block 0: Preparatory Module			
	SN259	Human Anatomy and Physiology	N/A	6
	SN260	Organic Chemistry	N/A	6
	Block 1: Introductory Module			
	FP092	Methodology of Scientific Research	N/A	3
	SN085	History of Biological-Naturist Medicine	N/A	3
	SN086	Biological Perspective of Organic Dysfunction	N/A	3
	SN017	Nutritional Biochemistry	N/A	3
	SN018	Nutritional Status Assessment	N/A	3
	SN101	Constitutional Types in Acupuncture, Homeopathy and Naturism	N/A	3
SN087	Naturist Diet and Dietary Sensibility	N/A	3	
SN136	Voll Electroacupuncture and Bioresonance	N/A	3	
Core subjects	Block 2: Mandatory Module:^a			
	MN012	Nutrition in Common Pathologies	N/A	3
	SN094	Anti-aging Therapy and Free Radicals	N/A	3
	SN096	Orthomolecular Therapy and Trace Elements	N/A	3
	SN099	Colon Hydrotherapy	N/A	3
	SN011	Phytotherapy	N/A	3
	SN088	Aromatherapy	N/A	3
	MTC001	Basic Theory (Part I)	N/A	3
	MTC002	Basic Theory (Part II)	N/A	3
	MTC003	Diagnostics	N/A	3
	MTC007	Differentiation of Syndromes	N/A	3
MTC008	MTC Therapy	N/A	3	
MTC009	Auriculotherapy	N/A	3	
Electives	Block 3: Optative Module: Acupuncture^b			
	MTC010	Meridian and Points (Part I)	N/A	3
	MTC011	Meridian and Points (Part II)	N/A	3
	MTC012	Acupuncture Techniques	N/A	3
	MTC013	Acupuncture - Internal Medicine	N/A	3
MTC014	Acupuncture – Specialties	N/A	3	

	Code	Subject	Pre-requisites	Credits	
Electives	Block 3: Optative Module: Traditional Chinese Phytotherapy				
	MTC016	Pharmacopeia 1	N/A	3	
	MTC017	Pharmacopeia 2	N/A	3	
	MTC018	Prescription	N/A	3	
	MTC019	Phytotherapy Treatment (MI)	N/A	3	
	MTC020	Dietetics in Traditional Chinese Medicine	N/A	3	
	Block 3: Optative Module: Homeopathy				
	MN005	Homeopathic Basics and Principles	N/A	3	
	MN006	Applications of the Homeopathic Principle	N/A	3	
	MN007	Homeopathic Medical Matter	N/A	3	
	MN016	Homeopathic Therapeutics in Acute Diseases	N/A	3	
	MN017	Homeopathic Therapeutics in Chronic Pathologies	N/A	3	
	Block 3: Optative Module: Biological-Naturist Methods				
	SN098	Kousmine Method	N/A	3	
	SN102	Homeopathy and Homotoxicology	N/A	3	
	SN103	Sophrology	N/A	3	
	SN105	Spagyria	N/A	3	
	SN097	Neural Therapy and Neurofocality	N/A	3	
	Block 3: Optative Module: Naturopathic Methods				
	MN014	Methods of Naturopathic Evaluations	N/A	3	
	MN015	Massage, Reflexology and Kinesiology	N/A	3	
	SN091	Heliotherapy, Thalassotherapy, Mud Therapy and Aerotherapy	N/A	3	
	SN090	Ozone Therapy	N/A	3	
	MN013	Iridology	N/A	3	
	Block 3: Optative Module: Natural Methods				
	SN104	Bach Flowers	N/A	3	
	MN018	Schüssler Salts	N/A	3	
	SN100	Hydrology, Mineral-Medicinal Waters and Balneotherapy	N/A	3	
	SN093	Pulsed Magnetic Wave and Hyperthermia	N/A	3	
	SN089	Biological-Naturist Therapies for Common Diseases	N/A	3	
	Requirements	Block 4: Supervised On-site Practices^c			
		MN019	Supervised On-site Practices	N/A	15
		Block 5: Master's Final Project^d			
MN100		Master's Final Project	N/A	10	
MTC025	Stage in Hospital	N/A			
TOTAL				94	

a) The student chooses 6 subjects (18 credits).

b) The acupuncture Optative module is not available to students of Puerto Rico.

c) The supervised on-site practices are regulated in Puerto Rico.

d) The student chooses between the Master's Final Project and the Stage at the Hospital.

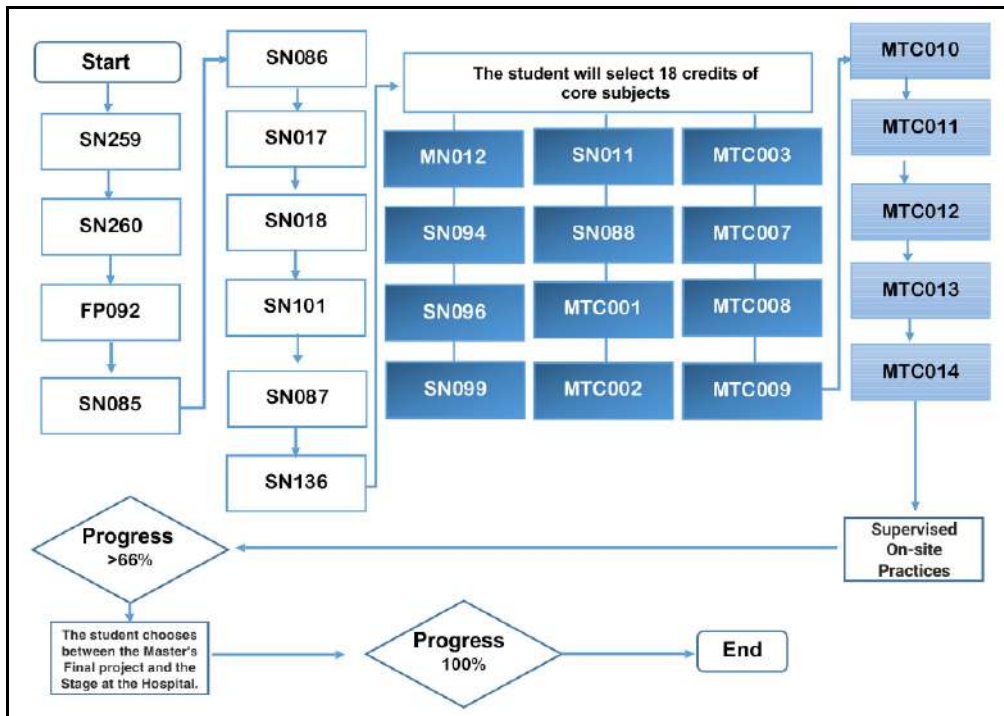


Figura 44: Flow Chart on the Master in Naturopathic Sciences. Optative Module: Acupuncture¹⁷.

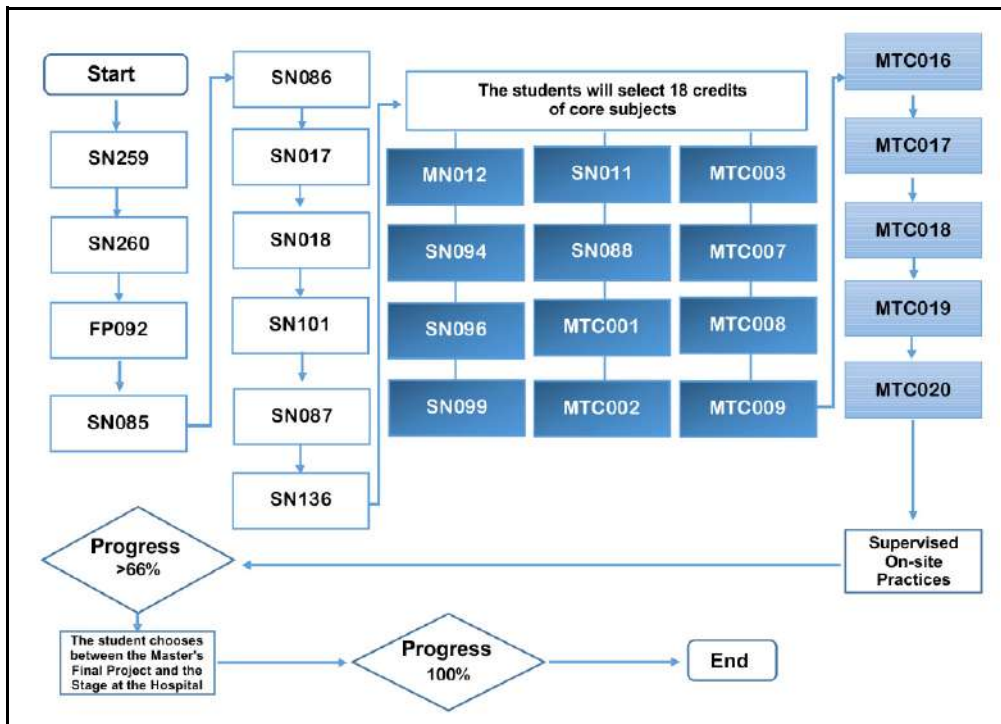


Figura 45: Flow Chart on the Master in Naturopathic Sciences. Optative Module: Traditional Chinese Phytotherapy¹⁸.

17. Subjects from the Optative Module are shown in blue. The acupuncture program is not available to students of Puerto Rico.
 18. Subjects from the Optative Module are shown in blue.

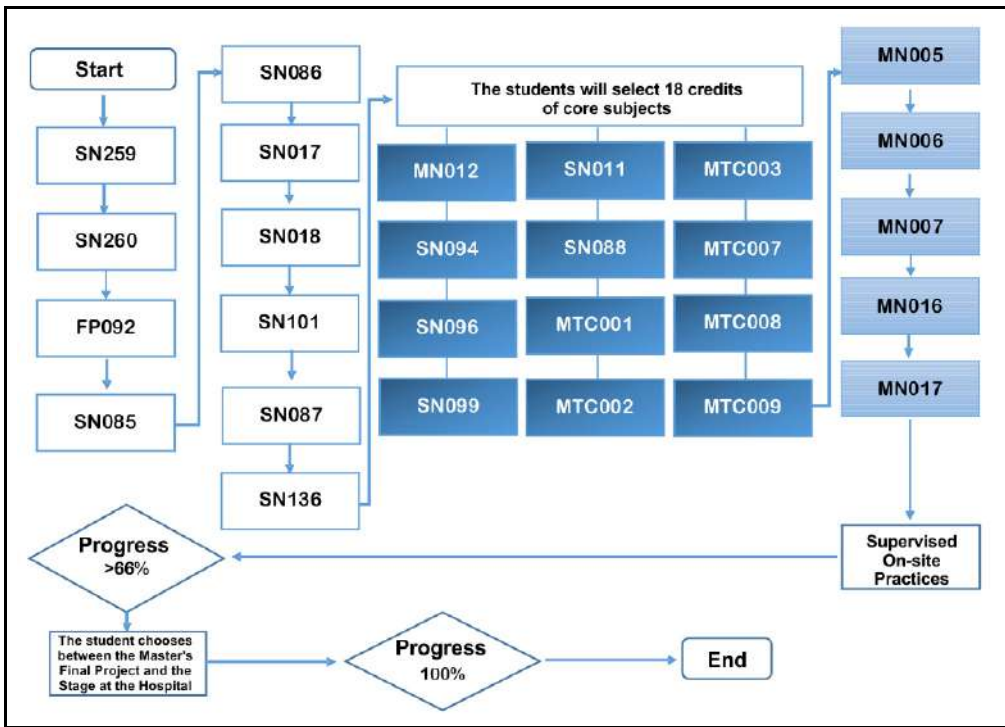


Figure 46: Flow Chart on the Master in Naturopathic Sciences. Optative Module: Homeopathy¹⁹.

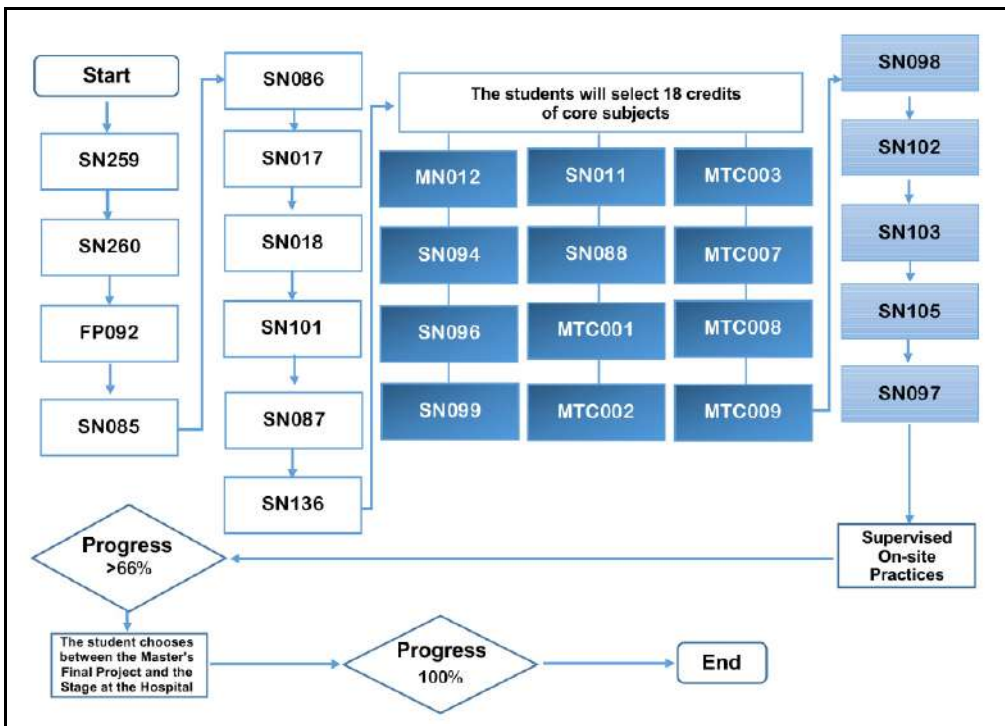


Figure 47: Flow Chart on the Master in Naturopathic Sciences. Optative Module: Biological-Naturist Methods¹⁹.

19. Subjects from the Optative Module are shown in blue.

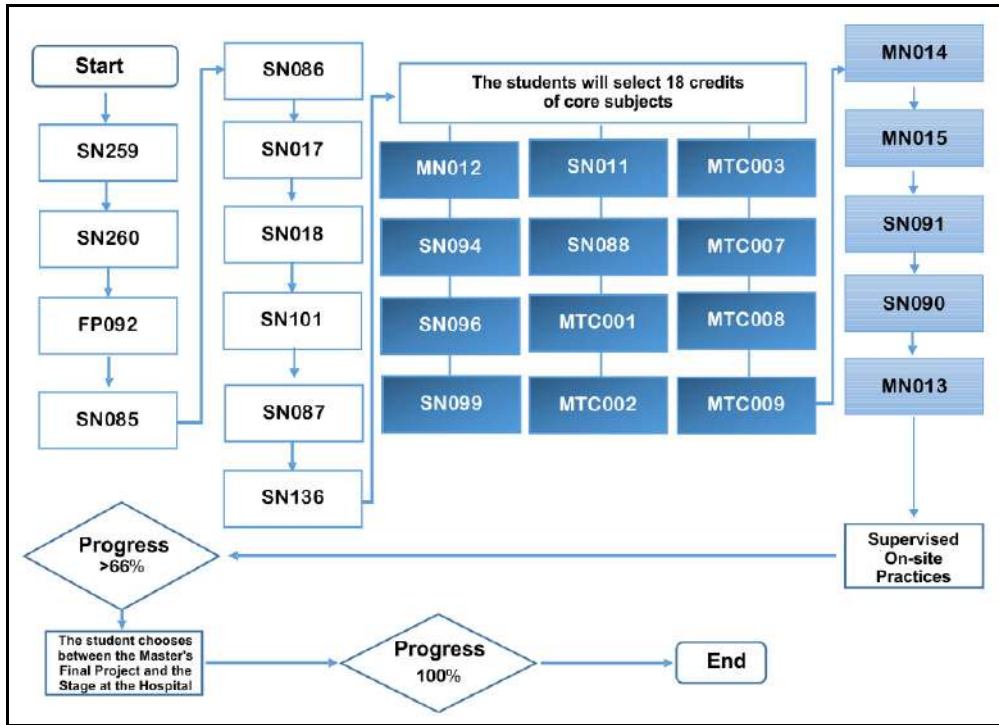


Figura 48: Flow Chart on the Master in Naturopathic Sciences. Optative Module: Naturopathic Methods²⁰.

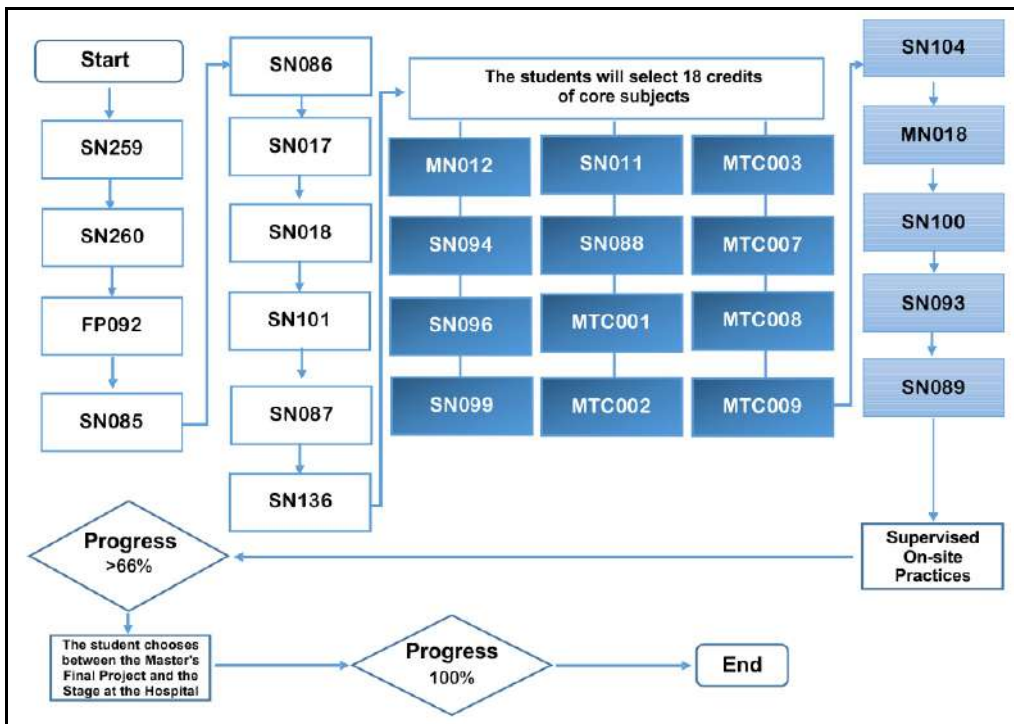


Figura 49: Flow Chart on the Master in Naturopathic Sciences. Optative Module: Natural Resources²⁰.

20. Subjects from the Optative Module are shown in blue.

- All subjects from all Masters are self-contained, and therefore do not have pre-requisites or co-requisites (Except for SN217 - Sports and Nutrition).
- The sequence of the subjects is determined by the student's work agenda. The subjects taken will also depend on the program's requirements and students' prior studies; they are adaptable to be favorable to the student.
- The subjects, following an asynchronous distance model, use the sequence of activities as the central points of the program, but allow the flexibility to move according to the progress of the student. Note that the subjects follow the sequence established in the previous tables, but without impeding the progress of the student (with exception to the two PF programs).

The charts show the sequence in which the student studies the subjects.

Please refer to the **Appendix** for the *Subject Description by Academic Departments*.

PROGRAMS OUTCOMES

Department of Language and Communication Science

Doctorate in Education with a specialty in Research

General Outcomes:

1. Provide the student with the fundamental concepts and research methodologies used in the area of Education and train them to design, develop and discriminate, individually and in group, research projects in the different lines offered and act as promoter in educational processes of different levels and environments.
2. Teach in new and not so known environments in broad education contexts, enabling student to use acquired knowledge, analyze and evaluate, make decisions and solve problems, contributing to the different approaches of educational research.
3. Provide scientific research tools that enable the student to manage educational projects and conduct research or creative work, demonstrating mastery of the material in an ethical manner.

Specific Outcomes:

1. Share knowledge, methodology and research methods related to the research lines of the program so that students can develop their thesis projects and integrate into a research community.
2. Participate in an environment appropriate for debate related to the epistemological and methodological problems of research projects linked to the achievement of the doctoral theses of the students.
3. Apply the knowledge acquired to the conception, design and implementation of research projects that can contribute to rethinking the education from the different lines of research.
4. Be able to analyze critically, evaluate and synthesize complex ideas.
5. Communicate with research professors and society about the areas studied.

6. Contribute, through an original investigation, to the development of knowledge that is worth national and international referenced publication.
7. Plan, perform, join and evaluate in a transversal manner, pedagogical projects of different areas of knowledge in different formal areas of education.

Master in Teaching Spanish as a Foreign Language

General Competencies:

1. Offering wide and up-to-date training for Spanish as a Foreign Language teachers in elementary, middle or high school in public and private institutions, and Spanish as a Foreign Language teachers in adult education, as well as graduates in related specialties who have the intention of working as Spanish as a Foreign Language teachers, providing the basis for the development of the academical and professional skills needed for teaching Spanish as a Foreign Language in any of the teaching-learning contexts with fluency, coherence and in an adequate way for the educational context in which they develop their professional activity.
2. Teaching in new or little known settings in wide contexts related to teaching Spanish as a Foreign Language so the student can apply the acquired knowledge, formulating opinions, making decisions and solving problems, reflecting on their own education and professional development.
3. Providing the scientific research tools that allow the student to use the methodological processes for pedagogical research of the language and applied linguistics applied to the Spanish language training.

Specific Competencies:

By completing the program, students will be able to:

1. To analyze, articulate and evaluate the learning and theory of second language acquisition and methodological trends in the teaching of foreign languages, essential for both effective teaching and effective learning.
2. Analyze how the individual factors (cognitive, affective, social and cultural) affect learning a foreign language, and as a consequence, the design of instructional strategies to broaden the student's learning needs in Spanish as a Foreign Language (FL).
3. Management of the Spanish as a Foreign Language (FL) classroom so that group processes guarantee the learning of all students: creation of a safe space in which all students participate and collaborate; the use of a discourse that encourages the construction of knowledge; the selection of activities of greater and lesser cognitive effort; selection of the most appropriate type of collaborative work for each activity; attention to learning opportunities that may arise, among other aspects.
4. Integrate the development of language skills in the Spanish as a Foreign Language classroom to promote real and meaningful language use.
5. To analyze, evaluate, select, adapt and design appropriate materials for teaching Spanish as a foreign language.
6. To make critical and reflective interpretations and to apply the cultural, linguistic and pragmatic knowledge acquired about the use of Spanish in the context of planning the process of teaching and learning Spanish as a foreign language (FL).

7. Analyze the function of the formal system and communication actions and provide an appropriate method in the Spanish classroom.
8. To plan and evaluate the teaching-learning process of Spanish in the short and long term, considering current pedagogical linguistic trends; the context of education; the methodological approach; lesson plans; the interests, needs and learning styles of the student; and technological advances.
9. To integrate ICT in a significant way, and not arbitrarily, in the activities of the process of teaching and learning Spanish as a foreign language, and to critically analyze the digital materials generated in this field.
10. To introduce specific training in learning strategies in the objectives and contents of the program and the units, whenever necessary and meeting the needs of the students, and use the necessary tool to learn how to learn.
11. To integrate socio-cultural content in the Spanish classroom in order to provide students the gradual knowledge of cultural facts and products, and the socio-cultural knowledge and attitudes of Spanish-speaking countries; the development of an intercultural awareness; the ability to act as a cultural intermediary and effectively address cultural misunderstandings in conflict situations; and the development of an attitude of empathy, openness and interest towards other cultures.
12. Properly address the Spanish varieties in the foreign language or second language classroom depending on each teaching and learning context.
13. Analyze and evaluate their own teaching and professional development through instruments such as self-observation, diary, self-evaluation, teaching portfolio, etc.; identify aspects of learning that can be improved; and plan and implement a personal plan for lifelong improvement.
14. To correctly access and use academic literature related to language pedagogy and Linguistics applied to the teaching of foreign languages, especially literature related to the Spanish language.
15. To design and evaluate specific methodological procedures for research in the field of language pedagogy and linguistics applied to the teaching of foreign languages, especially in research related to the Spanish language.

Master in Teaching English as a Foreign Language

General Competencies:

1. Leading, in an informed and well-supported manner, the situations and professional needs related to the working environment, encouraging autonomy without losing sight on elements of constant, but flexible, interaction adjusted to the specific necessities of the master in professional development; facilitating training for English masters in elementary, middle and high school in public and private institutions; English FL masters in adult education, and graduates.
2. Teaching in new or little known settings in wide contexts related to teaching English FL so the student can apply the acquired knowledge, formulating opinions, making decisions and solving problems, reflecting on their own education and professional development.
3. Providing the scientific research tools that allow the student to use the methodological processes for pedagogical research of the language and applied linguistics applied to the English language training.

Specific Competencies:

By completing the program, students will be able to:

1. To analyze, articulate and evaluate the learning and theory of second language acquisition and methodological trends in the teaching of foreign languages, essential for both effective teaching and effective learning.
2. Analyze how the individual factors (cognitive, affective, social and cultural) affect learning a foreign language, and as a consequence, the design of instructional strategies to broaden the student's learning needs in English as a Foreign Language (EFL).
3. Management of the English as a Foreign Language (EFL) classroom so that group processes guarantee the learning of all students: creation of a safe space in which all students participate and collaborate; the use of a discourse that encourages the construction of knowledge; the selection of activities of greater and lesser cognitive effort; selection of the most appropriate type of collaborative work for each activity; attention to learning opportunities that may arise, among other aspects.
4. Integrate the development of language skills in the English as a Foreign Language classroom to promote real and meaningful language use.
5. To analyze, evaluate, select, adapt and design appropriate materials for teaching English as a foreign language.
6. To make critical and reflective interpretations and to apply the cultural, linguistic and pragmatic knowledge acquired about the use of Spanish in the context of planning the process of teaching and learning English as a foreign language (FL).
7. Analyze the implications of English's role as a universal language in the teaching of English as a Foreign or Second Language.
8. Design learning proposals for an English as a Foreign Language (EFL) class that integrates the acquired knowledge of inter-language concepts and interaction in a foreign language class.
9. To plan and evaluate the teaching-learning process of English in the short and long term, considering current pedagogical linguistic trends; the context of education; the methodological approach; lesson plans; the interests, needs and learning styles of the student; and technological advances.
10. To integrate ICT in a significant way, and not arbitrarily, in the activities of the process of teaching and learning English as a foreign language, and to critically analyze the digital materials generated in this field.
11. To introduce specific training in learning strategies in the objectives and contents of the program and the units, whenever necessary and meeting the needs of the students, and use the necessary tool to learn how to learn.
12. Evaluate the usefulness of the method based on translation for teaching English and designing translation activities within the framework of teaching communicative language as a complementary tool for improving the English as a Foreign Language (EFL) learning process.
13. Analyze and evaluate their own teaching and professional development through instruments such as self-observation, diary, self-evaluation, teaching portfolio, etc.; identify aspects of learning that can be improved; and plan and implement a personal plan for lifelong improvement.

14. To correctly access and use academic literature related to language pedagogy and Linguistics applied to the teaching of foreign languages, especially literature related to the English language.
15. To design and evaluate specific methodological procedures for research in the field of language pedagogy and linguistics applied to the teaching of foreign languages, especially in research related to the English language.

Master in Education with a Specialization in Higher Education

General Competencies:

1. To provide a comprehensive and up-to-date training, as well as to provide the basis for the development of the academic and vocational skills required for teaching in any of the different teaching-learning contexts that may arise.
2. To ground professional practice on current knowledge, in new or unfamiliar educational settings; to provide insights into the nature of teaching and learning in general; and to develop the competencies, knowledge, skills and practical resources necessary to complete that theoretical basis.
3. To encourage critical thinking for a good theoretical formation and its necessary practical application, essential field of action; to develop good judgment, good decision making and problem solving; and to provide scientific research tools for the referenced contribution in innovative or current topics of higher education.

Specific Competencies:

By completing the program, students will be able to:

1. Analyze and evaluate learning factors.
2. Analyze and articulate the different learning theories and methodological bases in training.
3. To explain and point out the importance of the mentoring action in the educational system.
4. To explain the importance of strategic learning and its influence on professional development.
5. To apply ICT in the classroom as a teaching resource.
6. To design the methodology of scientific research.
7. To manage conflicts in the school setting.
8. To analyze the effect of interculturality on education.
9. To analyze and articulate the different processes of attention to diversity.
10. To organize and manage educational centers.
11. Integrate environmental education into formal education.

Master in Organization and Management of Educational Centers

General Competencies

1. To provide the tools related to the study, planning, consulting and advisory services for the organization and management of educational institutions, so that knowledge and skills are developed to plan, organize, direct, control, propose and drive innovation for the improvement of educational institutions.

2. To stimulate critical reflection, the development of good judgment, good decision making and problem solving, and to provide scientific research tools for contributions in innovative or current educational issues.

Specific Competencies

By completing the program, students will be able to:

1. Analyze the different types of projects according to their purposes and forms of management, and identify the elements, phases and human and material resources needed to implement them.
2. Plan and design a project adjusted to the needs of a certain context.
3. Analyze and integrate the methods and styles of strategic management.
4. Identify the elements of a management system within the education sector and develop objectives and action plans for strategic management under different contexts.
5. To identify educational institutions as a global system that integrates their units in a coherent way.
6. To analyze the factors that favor educational quality and innovation, and to contrast the different models for the evaluation of training processes.
7. To analyze and evaluate the quality of educational innovation and develop an innovation project for the classroom.
8. To analyze the main constructs related to management techniques and teamwork, and to describe the tools and techniques to improve the efficiency of this type of work.
9. To properly apply the techniques of management and teamwork in a given educational context.

Master in Education with a Specialty in Professor Training

General Competencies:

1. To provide a comprehensive and up-to-date training, as well as to provide the basis for the development of the academic and vocational skills required for teaching in any of the different teaching-learning contexts that may arise.
2. To ground professional practice on current knowledge, in new or unfamiliar educational settings; to provide insights into the nature of teaching and learning in general; and to develop the competencies, knowledge, skills and practical resources necessary to complete that theoretical basis.
3. To encourage critical thinking for a good theoretical formation and its necessary practical application, essential field of action; to develop good judgment, good decision making and problem solving; and to provide scientific research tools for the referenced contribution in innovative or current topics of Professor Training.

Specific Competencies:

By completing the program, students will be able to:

1. Identify the basic concepts related to the curriculum and critically analyze its different approaches (thematic content, learning or competencies) and the different stages in the construction of a curriculum proposal.

2. Plan and evaluate learning processes, keeping in mind the teaching-learning context, the methodological approach, the class plans and the students' needs, interests and styles of learning.
3. Identify the different types of assessment and select the most appropriate instruments to evaluate the learning process of students.
4. Distinguish the different teaching-learning methodologies and the didactic techniques derived from each one.
5. Select and apply appropriate teaching-learning techniques to achieve the learning objectives established in a given educational context.
6. Identify and apply the criteria for the design, adaptation and evaluation of didactic resources according to the learning needs of a specific educational context.
7. Design or adapt didactic materials and construct instruments to evaluate them.
8. Identify the characteristics of the methodological approach "Content and Language Integrated Learning (CLIL)" and assess its application in a given educational context.
9. Design didactic proposals based on the CLIL approach.

Master in Education with a Specialty in Professor Training

General Competencies:

1. To provide a comprehensive and up-to-date training, as well as to provide the basis for the development of the academic and vocational skills required for teaching in any of the different teaching-learning contexts that may arise.
2. To ground professional practice on current knowledge, in new or unfamiliar educational settings; to provide insights into the nature of teaching and learning in general; and to develop the competencies, knowledge, skills and practical resources necessary to complete that theoretical basis.
3. To encourage critical thinking for a good theoretical formation and its necessary practical application, essential field of action; to develop good judgment, good decision making and problem solving; and to provide scientific research tools for the referenced contribution in innovative or current topics of ICT.

Specific Competencies:

By completing the program, students will be able to:

1. Analyze the concept of e-learning and virtual teaching and learning environments, and distinguish the different types of virtual environments.
2. Identify the characteristics of teaching and learning in virtual learning environments.
3. Plan and evaluate learning processes in virtual environments, taking into account the teaching-learning context, the methodological approach, and the interests, needs and learning styles of the students.
4. Identify and manage the different technological resources and tools from information and communication technologies.
5. Select and apply the different tools and resources in a creative way in the design of pedagogical proposals adjusted to one's own learning context.
6. Identify the main learning theories applied to ICT.

7. Relate learning theories to the use, selection, organization and evaluation of ICT.
8. Identify the sociocultural theoretical postulates that support collaborative learning in a virtual environment.
9. Describe and evaluate the technologies that favor collaborative work in virtual teaching-learning environments.
10. Identify the theoretical bases that support innovative educational proposals based on ICT.
11. Design and evaluate training proposals based on ICT.

Department Department of Innovation, Business and New Technologies

Master in Strategic Management with a Specialty in Management

General Competencies:

1. To offer education to train professionals (especially from the engineering, social sciences, management sciences and economics fields) in the area and practice of Strategic Management, by providing executive thinking to allow the student to assume their current and/or desired managerial positions, or to develop their professional trajectory in the field of organizational consulting
2. To teach in new or unfamiliar environments within the broad contexts related to their area of study. Thus, the student can apply the knowledge acquired (making judgments and decisions and solving problems). All this will help the student to understand the strategic process of organizational management, to assume roles within the strategic management process and to create proposals that integrated globalized and local processes to run a business.
3. To provide scientific research tools that will allow the student to conduct research or produce creative work in an ethical manner, thus showing mastery of the content

Specific Competencies:

By completing the program, students will be able to:

1. Design a strategic process starting from the diagnosis and organizational appraisal to development the objectives and select the strategy.
2. Analyze and explain the organizational environment to improve internal processes, including standards, regulations, certifications and accreditations.
3. Integrate administrative processes and Information Technology (IT) for decision making and conflict resolution.
4. Create the marketing mix of a business and propose the market research design.
5. Analyze and apply conflict resolution techniques and human resource knowledge for effective management of the work environment and human resource development.
6. Design strategies for continuous improvement in operations that influence the competitiveness and viability of the company.
7. Identify roles, approaches and practices to manage different sizes and business purposes, applying management accounting as a method to make financial decisions that help maximize the business economy.

8. Manage administration and leadership skills, maintaining honest and transparent administration principles in the achievement of objectives.

Master in Strategic Management with a Specialty in Information Technology

General Competencies:

1. To provide knowledge to professionals of different degrees, as well as the skills and abilities necessary to run a managerial position of Systems and ICT, to direct an organizational change project using ICT or to advise companies that need to respond to the competitiveness of new businesses.
2. To provide the foundations of business innovation that ensure that strategies and NICT strategies are aligned and are coherent with business development, from strategic management to personnel management, with an emphasis on continuous and permanent changes.
3. To teach in new or unfamiliar environments within the broad contexts related to their area of study. Thus, the student can apply the knowledge acquired (making judgments and decisions and solving problems). In addition, the student will receive scientific research tools that will allow them to conduct research or produce creative work in an ethical manner, thus showing mastery of the content.

Specific Competencies:

By completing the program, students will be able to:

1. Analyze conflicts and identify and define appropriate technology and information system requirements.
2. Assess technological solutions, systems, processes, components or programs to meet the needs and requirements of the company, and its impacts on the organization.
3. Combine strategic planning and management techniques and skills in the field of information systems.
4. Evaluate current and emerging technologies related to organizational operation.
5. Distinguish and consider professional, ethical, legal and social responsibility.
6. Combine software reengineering techniques and skills to develop, design and manage databases, software and information systems.

Master in Strategic Management with a Specialty in Telecommunications

General Competencies:

1. To provide an understanding of the Telecommunication networks and services for those individuals that wish to understand the concept from the organizational and global society point of view, with a strategic perspective integrated into the social dynamic and current economics, while acquiring an overall knowledge of the different technological possibilities for current and future networks.
2. Teaching about new or relatively unknown environments within broad contexts that are related to their area of study, so that the student may propose and implement organizational strategies based on Telecommunications and/or integrate Telecommunications in a business, formulating judgments, making decisions and solving problems.

3. Provide special attention to the different services provided by networks and telecommunications, and the new business opportunities that companies offer. To also provide the basis for business innovation seated in strategic management and aligned to the organizational strategies with those of Telecommunication strategies and to provide the tools for scientific research that will enable the student to conduct research or produce creative work, and so demonstrating a mastery of the material in an ethical manner.

Specific Competencies:

By completing the program, students will be able to:

1. Evaluate current and emerging telecommunications applications and services.
2. Manage proposals, solutions, planning and development of telecommunication projects.
3. Combine Project Management principles and techniques to manage telecommunication projects.
4. Combine Project Management principles and techniques to manage human resources and occupational safety.
5. Evaluate the regulations, laws and environmental framework of the telecommunications industry.

Department of Projects

Doctorate in Projects with a specialty in Research

General Outcomes:

1. Provide students with a solid scientific training, providing a profile of specialization in research and derived in a field of intensification in the area of project design.
2. Teach in new and not so known environments in broad education contexts, enabling student to use acquired knowledge, analyze and evaluate, make decisions and solve problems to create, design and perform projects.
3. Provide scientific research tools that enable the student to manage educational projects and conduct research or creative work, demonstrating mastery of the material in an ethical manner

Specific Outcomes:

1. Analyze the theory of projects, define the scope of the investigation, and identify the subject of the dissertation, objectives, assumptions and methodology; with the support of a professor/tutor to elaborate the proposal of the doctoral thesis.
2. Provide solutions that contribute to human, scientific and technological development in the field of project design that enables a wider vision of the research line.
3. Interpretation and analysis of the role of the people and the dimension of sustainability in the formulation and development of projects in order to realize them in his line of research.

Master in Project Design, Administration and Management

General Competencies:

1. Providing high level study discipline for professionals with college training in any knowledge field who have the inquisitiveness to get involved in the world of projects in a responsible manner, allowing to manage in the field of project teaching and research and/or the professional field.
2. Teaching in new or little known settings in wide contexts related to project design, operation and management, from its formulation to its subsequent analysis, regardless of its origin and purpose, so the student can apply the acquired knowledge, formulate opinions, make decisions and solve problems.
3. Providing training in the use of up-to-date computerized tools in the professional field and in the pedagogical expression of theoretical fundamentals and practical cases, the application of the technological tools for project programming and management and scientific research tools that allow the student to lead researches or produce creative work in an ethic manner, proving mastery of the material.

Specific Competencies:

By completing the program, students will be able to:

1. Defining basic concepts in the field of project creation, management and direction.
2. Recognizing and analyzing the fundamental aspects of a project, in order to strategically define its objectives, the service to be provided, the way it is provided, the ergonomics required and the project's functional aspects.
3. Designing a project draft considering its basic aspects. This is done through the problematic situation's definition to the solution proposal's presentation, recognizing the necessary elements to define and specify for the future management and materialization of the proposal.
4. Analyse the key aspects of managing a project in its various life cycles: stakeholder recognition, user requirements, team management and the basic issues that define its feasibility and viability.
5. Identifying the elements that contribute quality, security and reliability to the project, as well as those that represent important risks, analyzing also the possible impact that this could cause in its environment.
6. Develop a balanced scorecard with indicators on human resource management, division of work and activity organization structures and others that facilitate their implications in strategic business decision making.
7. Incorporating project management and direction tools to favor the correct handling of resources, the schedule and of the available ITC tools within the scope of the projects.

Master in Project Design, Administration and Management with a Specialty in Architecture and Urban Planning

General Competencies:

1. Offering knowledge on organized urban growth and the physical modification of the city by means of all interventions, based in urban-architectonic project methodology from a

comprehensive perspective of project design, operation and management with the goal of training professionals with high social and ethic compromise and a global vision on what the involvement of a city implies.

2. Teaching in new or little known settings in wide contexts related to their field of study so the student can apply the acquired knowledge, formulating opinions, making decisions and using methodologies to solve urban and architectonic problems which can lead to redesign the physical spaces occupied by humans nowadays.
3. To provide scientific research tools that will allow the student to produce creative work in an ethical manner, thus showing mastery of the content

Specific Competencies:

By completing the program, students will be able to:

1. Define basic concepts in the field of architectural and urban planning projects.
2. Designing a project draft considering its basic aspects. This is done through the problematic situation's definition to the solution proposal's presentation, recognizing the necessary elements to define and specify for the future management and materialization of the proposal.
3. Recognize and analyze the fundamental aspects of a project in the field of architecture and urban planning in order to strategically define the service to be provided, the required ergonomics and the functional aspects of the project.
4. Analyze the key aspects of managing an urban-architectural project: stakeholder recognition, user requirements, team management and the basic issues that define its feasibility and viability.
5. Identifying the elements that contribute quality, security and reliability to the project, as well as those that represent important risks, analyzing also the possible impact that this could cause in its environment, and existing models of sustainable development and eco-design.
6. Incorporating the basic project management and direction tools to favor the correct handling of resources, the schedule and of the available ITC tools within the scope of the urban-architectural projects.

Master in Project Design, Administration and Management with a Specialty in Innovation and Product

General Competencies:

1. To provide professionals with knowledge in the fields of innovative product design. In other words, any tangible or intangible element that is produced by a project, with a strong presence of the "design" characteristic in its development phases.
2. To teach in new or unfamiliar environments within the broad contexts related to their area of study. Thus, the student can apply the knowledge acquired (making judgments and decisions and solving problems) in all phases of innovative product design, from the development phase to the subsequent analysis.
3. To provide scientific research tools that will allow the student to conduct research or produce creative work in an ethical manner. Thus, showing mastery of the content and validating the training of professionals with high social and commitment and with an open vision to incorporate new development processes (design) of innovative projects.

Specific Competencies:

By completing the program, students will be able to:

1. Defining basic concepts in innovation and product within the projects' field.
2. Designing a project draft considering the basic aspects of an innovation project. This is done through the problematic situation's definition to the solution proposal's presentation, recognizing the necessary elements to define and specify for the future management and materialization of the proposal.
3. Recognizing and analyzing the fundamental aspects of a project offering a service or innovative product, in order to strategically define the service to be provided, the ergonomics required and the functional aspects of the project.
4. Analyzing a project's key management aspects with innovative contributions: recognizing the stakeholders; users' requirements; working teams' management; and basic questions defining its feasibility and viability, considering the aspects referred to patenting and the rights to intellectual property.
5. Identifying the elements that contribute quality, security and reliability to the project, as well as those that represent important risks, analyzing also the possible impact that this could cause in its environment, considering the processes of design and manufacture of products.
6. Incorporating basic tools of project management and direction to favor the correct handling of resources, the schedule and of the available ITC tools within the scope of the projects of innovation and product.

Master in Environmental Management and Auditing

General Competencies:

1. To provide university graduates who have an intermediate or higher degree with environmental training in management and environmental audits in order to improve their skills in the professional contexts in which they work, or to guide work expectations.
2. To teach advanced specialized and multidisciplinary education in new or unfamiliar environments within the broad contexts. Thus, the student can apply the knowledge acquired (making judgments and decisions and solving problems). This will allow the student to work in the fields of consulting and research. In addition, it will lead to the training of multidisciplinary environmental professionals who contribute to the growth of new companies or, who wish to update and improve their understanding of the new business opportunities that the environmental variable represents, should the case arise.
3. To provide scientific research tools and to facilitate the necessary integration of the environmental variable in the cultural and technological policies of the organization, so that the student can conduct research or produce creative work; thus, showing mastery of the content in an ethical manner.

Specific Competencies:

By completing the program, students will be able to:

1. Define the concept of sustainable development within the social-political, economic and environmental conditions in a country in its transition toward a low-carbon economy and assess the potential difficulties in the term's application in public policies.

2. Explain the relations that are established between the environmental conditions and the characteristics of the species, and interpret the mechanisms for the exchange of matter and energy that occur in aquatic and terrestrial ecosystems, influencing the population strategies of the organisms and how they may be affected by the effect of the anthropic pollution.
3. To develop and evaluate global and local strategies in the integrated management of natural resources, water, waste, atmosphere, noise and soil, in the context of environmental education and law.
4. Develop a comprehensive model that brings a series of variables together (social, environmental, economic, etc.) and define the tools necessary for its implementation in impact studies and life-cycle analysis, as well as its instrumentalization in different standards ISO 14001, ISO 19011 and ISO 14067.
5. Interpret the direct and indirect methods of monetary valuation for the environment and its relation with the internalization of externalities.
6. Compare the technologies that are currently applied to the production of heat and electricity from renewable energy sources (solar, wind, hydraulic, etc.) and assess how the variability of the designs influences the climatic parameters and other types.
7. Identify the variables (social, economic and environmental, among others) that are part of a climate assessment and relate them with government policies of adaptation and the technologies and existing models of mitigation carried out in indicators of implementation in different sectors.

Master in Physical Activity: Sports Training and Management

General Competencies:

1. To offer training in physical activity, sports design and planning, and the management of sports centers, aimed at professionals with diplomas and/or degrees in physical education, teachers, health and sports science professionals and all those who wish to improve their professional careers with subjects related to sports management.
2. To teach in new or unfamiliar environments within the broad contexts by providing the knowledge and resources that the student will use to make judgments and decisions, and solve problems.
3. To provide scientific research tools that will allow the student to conduct research or produce creative work, thus showing mastery of the content in an ethical manner.

Specific Competencies:

By completing the program, students will be able to:

1. To seek to obtain and process information applied to scientific methodology and procedures to communicate and transform it into knowledge and apply it in the solution of conflicts related to the framework of sports and sports management.
2. To analyze the main adaptations of the human body and apply the principles of biomechanics, physiology, psychology and social to the different fields of sport and nutrition, identifying inappropriate practices that are a risk to health, to prevent and correct them at different levels of action, age and population groups.
3. To identify the athlete's individual characteristics that influence them and determine their sport actions for the planning, programming, implementation, monitoring, quantification and

evaluation of the training process and competences in its different levels of action, periods of competitiveness, age and population.

4. To analyze and resolve conflicts related to sports actions, as well as to make informal decisions about the solution of individual professional tasks and in collaboration with others.
5. To plan, implement strategies, develop and evaluate appropriately the professional tasks related to the field of training and sport management, adopting the ethical and legal commitments and the conceptual framework and responsibilities required by the profession.
6. To use the analysis, interpretation and application of information and communication technologies within reflexive knowledge for the practical solution of professional and academic tasks proposed in the sports field.
7. To identify the influence that nutrition and eating have as a tool to improve the elite athlete's performance.
8. Describes and explains the management of infrastructure and technical areas of a sports organization and the processes to improve them, identifying opportunities for information systems.
9. To train managers and qualified personnel with business and human relations skills to manage sport companies and institutions and to understand the sports market.
10. To acquire the skills that enable continued training and learning of the sport field through contact with the professor or in an autonomous way.
11. Acquire and consolidate the initiative, the entrepreneurial spirit to launch sports management projects.
12. To analyze and identify different leadership styles, promoting the development of skills and attitudes to lead collective professional development sports projects and transfer the progress in the formerly experienced discipline to society.

Master in Naturopathic Sciences

General Competencies:

1. To train professionals in the field of Naturopathy who will contribute in a relevant way to the scientific development of the arts and health sciences, and of a more productive and healthy society. They will be able to educate and guide on the different aspects and modalities of Naturopathy (techniques, lifestyles and natural therapies that are in harmony with this practice); and to practice therapeutic methods.
2. To teach in new or unfamiliar environments of the Naturopathic sciences and to interact and participate with doctors and other health professionals in the interdisciplinary management of the patient's health. They will reflect on their own teaching and professional development and thus, apply their knowledge to prescribe and recommend natural or integral food and other natural products that do not require a doctor's prescription by exercising good judgment, making decisions and solving problems.
3. To provide scientific research tools that will allow the student to use methodological processes for applied research in the field of Naturopathic sciences.

Specific Competencies:

1. To collaborate in the search for sustainable socio-sanitary solutions that have a positive impact on the greatest number of communities and individuals.

2. To design and manage innovative health service offers that influence the development of people's quality of life.
3. To review and recommend profession-specific modalities with scientific backing.
4. To analyze, evaluate and apply different therapies in natural health within different physiological and pathological situations.
5. To review, analyze and apply the necessary knowledge about the practical skills required to develop their knowledge in the evaluation and therapeutic methods characteristic of the profession and in harmony with the statutes of law.
6. To analyze and rethink theoretical and practical aspects through workshops, seminars, symposiums, practices, etc.
7. To analyze, evaluate and design scientific research at a higher level.

ADMISSIONS REQUIREMENTS

The Universidad Internacional Iberoamericana requires the following documents for admission, all of which are subject to verification and validation without violating the privacy of the candidate's information, as long as there is no data or information falsification. The University reserves the right to verify and validate the information in specific cases by notifying the candidate.

The University shall have a website for online admission, as an additional means to its offices.

All admitted students must sign the "Enrollment Agreement" document.

ADMISSION POLICY

- Have graduated from an accredited or recognized University from any country with a bachelor's or equivalent.
- Know the language of the program taught. If necessary, provide accredited documentation or the corresponding fluency test. For the FPMELE and FPMTFL programs, the language comprehension test should be taken when required.
- Being distance programs that are not subject to on-site classes, there is no specific start date, by which the student may formalize the application at any time, as long as there are available spaces. However, the masters that have a group work modality (MDGDP) or that must follow a determined line for their studies (FPMELE-FPMTFL), will be subject to specific beginning dates.

MDGDP - design modules begin in the months of March and September.

FPMTFL, FPMELE and FPMME - The calls are in the months of February, June and October.

The enrollment is open all year round but is consolidated to make an income and enroll in the indicated periods.

DOCUMENTS TO SUBMIT

If the previous requirements are complied with, the following should be requested and submitted to the Admissions Department:

For Students of the Master

- Electronic Tuition Form.
- Notarized photocopy of the degree (bachelor's degree) or notarized photocopy of the official credit transcript of the degree.
- Simple passport photocopy from the page where the degree information is printed on the document. Or, in its stead, an accredited identification document from your country, such as a national identity card or driver's license (where a DNI card is not used, such as in the U.S.)

For Students of the Doctorate:

- Electronic Tuition Form.
- Notarized photocopy of the degree (bachelor's degree) or notarized photocopy of the official credit transcript of the degree.
- Notarized photocopy of the degree (master's degree) or notarized photocopy of the official credit transcript of the master.
- Simple passport photocopy from the page where the degree information is printed on the document. Or, in its stead, an accredited identification document from your country, such as a national identity card or driver's license (where a DNI card is not used, such as in the U.S.)

The admission process begins once the candidate has submitted the documentation. Additional information may be requested during this process.

Notes:

- In the event of documents from abroad, the documents will be evaluated and reviewed by the University and may be subject to required verifications and/or legalizations relevant by the University.
- The applicant shall be responsible for the translation if the documentation is in a language other than English, Spanish or Portuguese.

ADMISSION REQUIREMENTS BY PROGRAM

PROGRAMS	ADMISSIONS REQUIREMENTS
Doctorate in Education with a Specialty in Research	<ul style="list-style-type: none"> • Have a Master's degree. • Undergo an interview with the program directors, either in situ or online (Skype, Messenger, Google talk, etc.).
Doctorate in Projects with a Specialty in Research	<ul style="list-style-type: none"> • Have a Master's degree. • Undergo an interview with the program directors, either in situ or online (Skype, Messenger, Google talk, etc.).

PROGRAMS	ADMISSIONS REQUIREMENTS
<p>Master in Teaching Spanish as a Foreign Language</p>	<ul style="list-style-type: none"> • Have graduated from an accredited or recognized University from any country with a bachelor's or equivalent. <p>Linguistic requisites:</p> <ul style="list-style-type: none"> • To enter the program, non-Hispanic speakers must prove sufficient proficiency of Spanish in an academic environment. This proficiency is recognized to those who can prove that they have completed a university degree related to the area in universities from Spanish-speaking countries. However, this recognition is not automatic and it happens upon careful evaluation of the candidate's documentation. • In case of not having this degree, the individual must submit other documentation (such as, the Higher Diploma of Spanish as a Foreign Language from the Cervantes Institute) or any other similar one. • If the candidate does not have any type of certification attesting to the required level of language, or their university qualifications are not adequate, the candidate must take an admissions test.
<p>Master in Teaching English as a Foreign Language</p>	<ul style="list-style-type: none"> • Have graduated from an accredited or recognized University from any country with a bachelor's or equivalent. <p>Academic requirements BA Honors (4 years of university studies) in a field relating to Educational Studies, Languages or Social Sciences. Degrees in other areas will also be considered for admission on the MA programme prior to completion of the entry exam. If the candidate has ample experience in the TEFL field and holds an Ordinary degree (3-year degree), they may be admitted onto the MA course prior to individual evaluation by the Admissions Director.</p> <p>Teaching experience: For all the courses in TEFL (Master, Diploma, Certificates) a minimum of one year's teaching experience in ELT at any type of institution or in private tuition, is recommended. For the Certificates, if the candidate has no previous teaching experience, he/she may be asked to do an entrance exam before being admitted onto the course.</p> <p>Linguistics requirements: All candidates who are non-native speakers of English will have to provide evidence of having passed one of the following exams: Cambridge: <ul style="list-style-type: none"> • Cambridge FCE (First Certificate) - grade A. (Grade B or C requires the entrance exam to be taken) • I TOEFL: There are 3 versions of this exam: <ul style="list-style-type: none"> • Paper-based test (PBT) is out of a total 677 points, a minimum of 550 points is required. • Computer-based test (CBT) is out of a total 300 points, a minimum of 230 points is required. Internet-based test (iBT) is out of a total 120 points, a minimum of 79 is required.</p> <p>Michigan Test: ECEP (Examination for the Certification of Proficiency in English) - a pass. The Michigan ECCE (Examination for the Certification of Competency in English) is not accepted since the level is too low. If the candidate does not have any of the above-mentioned certificates, and if he/she is not a native English speaker, then he/she will have to sit the entrance exam. English certificates from any other language schools will generally not be accepted, but may still be submitted for evaluation by the teachers on the course. If no consensus is reached regarding the qualification, the candidate will have to sit the entrance exam. Anyway, having English as an L1 doesn't presuppose that a student has the linguistic level that this Masters demands. So, as a last resort, the company's management team of this programme can demand that the candidates pass a test that proves that they possess the level required.</p>
<p>Master in Project Design, Administration and Management</p>	<ul style="list-style-type: none"> • Have graduated from an accredited or recognized University from any country with a bachelor's or equivalent. • Know the language of the program taught. Provide supporting documentation if necessary or take the corresponding comprehension test.
<p>Master in Project Design, Administration and Management with a Specialty in Architecture and Urban Planning</p>	<ul style="list-style-type: none"> • Have graduated from an accredited or recognized University from any country with a bachelor's or equivalent. • Know the language of the program taught. Provide supporting documentation if necessary or take the corresponding comprehension test.

PROGRAMS	ADMISSIONS REQUIREMENTS
Master in Project Design, Administration and Management with a Specialty in Innovation and Product	<ul style="list-style-type: none"> • Have graduated from an accredited or recognized University from any country with a bachelor's or equivalent. • Know the language of the program taught. Provide supporting documentation if necessary or take the corresponding comprehension test.
Master in Strategic Management with a Specialty in Management	<ul style="list-style-type: none"> • Have graduated from an accredited or recognized University from any country with a bachelor's or equivalent. • Know the language of the program taught. Provide supporting documentation if necessary or take the corresponding comprehension test.
Master in Strategic Management with a Specialty in Information Technology	<ul style="list-style-type: none"> • Have graduated from an accredited or recognized University from any country with a bachelor's or equivalent. • Know the language of the program taught. Provide supporting documentation if necessary or take the corresponding comprehension test.
Master in Strategic Management with a Specialty in Telecommunications	<ul style="list-style-type: none"> • Have graduated from an accredited or recognized University from any country with a bachelor's or equivalent. • Know the language of the program taught. Provide supporting documentation if necessary or take the corresponding comprehension test.
Master in Environmental Management and Auditing	<ul style="list-style-type: none"> • Have graduated from an accredited or recognized University from any country with a bachelor's or equivalent. • Know the language of the program taught. Provide supporting documentation if necessary or take the corresponding comprehension test.
Master in Physical Activity: Sports Training and Management	<ul style="list-style-type: none"> • Have graduated from an accredited or recognized University from any country with a bachelor's or equivalent. • Know the language of the program taught. Provide supporting documentation if necessary or take the corresponding comprehension test.
Master in Education with a Specialization in Higher Education	<ul style="list-style-type: none"> • Have graduated from an accredited or recognized University from any country with a bachelor's or equivalent. • Know the language of the program taught. Provide supporting documentation if necessary or take the corresponding comprehension test.
Master in Organization and Management of Educational Centers	<ul style="list-style-type: none"> • Have graduated from an accredited or recognized University from any country with a bachelor's or equivalent. • Know the language of the program taught. Provide supporting documentation if necessary or take the corresponding comprehension test.
Master in Education with a Specialty in Training for Teachers	<ul style="list-style-type: none"> • Have graduated from an accredited or recognized University from any country with a bachelor's or equivalent. • Know the language of the program taught. Provide supporting documentation if necessary or take the corresponding comprehension test.
Master in Education with specialization in ICT in Education	<ul style="list-style-type: none"> • Have graduated from an accredited or recognized University from any country with a bachelor's or equivalent. • Know the language of the program taught. Provide supporting documentation if necessary or take the corresponding comprehension test.

PROGRAMS	ADMISSIONS REQUIREMENTS
Master in Naturopathic Sciences	<ul style="list-style-type: none"> • Have graduated from an accredited or recognized University from any country with a bachelor's or equivalent. • Know the language of the program taught. Provide supporting documentation if necessary or take the corresponding comprehension test. • Students from Puerto Rico should comply with the 90 credits from the general university studies and those from basic natural sciences. This preparation should include the following subjects: general biology, general chemistry and general physics.

TECHNOLOGICAL REQUIREMENTS

Necessary technical skills and knowledge to successfully access and complete your studies

All of the students from the programs of the Universidad Internacional Iberoamericana receive the necessary instructions to study their courses at the beginning of the program, covering both the acquisition of skills in the use and management of information resources as well as the integration of other students and the university community.

Description of the necessary technical and programming equipment for the distance subject

In distance education programs, it is necessary for the Faculty to have a computer with the following software, hardware and infrastructure for the virtual campus's current configuration of the university:

Equipment

- Mid-range Computer or higher. At the time of writing this document, 3 Ghz Intel Pentium G860.
- Monitor.
- Webcam and audio system. The Program's development requires video conferences to be conducted, and supervised exams that use these devices.

Infrastructure

- Internet connection for a minimum of 2 continuous hours a day.

Software

The following programs to be installed on computers (indicates the recommended configuration):

- Operating System (their latest versions):
 - Mac OS X.
 - GNU/Linux - Ubuntu or Linux Mint distribution.
- Web Browsers (their latest versions):
 - Mozilla Firefox.
 - Google Chrome.

- Microsoft Internet Explorer.
- Safari.

Notes:

- * It is recommended to always have the latest browser version.
- * All browsers must enable JavaScript™.
- * To use the chat rooms and Whiteboard, Java™ must be enabled.
- * To use the ticket based authentication, browser cookies should be enabled.
- * All technical specifications delivered can vary in order to improve the quality of student performance. Any changes will be reported and will not affect current students.
- * These specifications do not prevent any student from entering a program because the computer services offered by the University are accessible by the many computers available in public places or computers rented per hour. However, the above characteristics are the ones that allow efficient performance and enable optimum use of educational resources available in the Virtual Campus. It is recommended to always have computer access.

ADMISSION TO THE UNIVERSITY

Candidates who meet the admissions requirements for the program of interest and the University has received the tuition payment will be the only ones admitted; they will be notified via the Admissions Department.

PROCESS REVIEW

The application process may require review by the Coordination Department or the Dean of Student Affairs, who establish the admission criteria. These entities of the University may require or provide details of the applicant or university candidate.

The candidate can and should make any requests to the Dean of Students Affairs through official means during the admissions process.

During this process, the Dean of Students Affairs will request the Department Director the studies program in which the candidate is interested.

ENROLLMENT AGREEMENT

If the admission is approved, the student must sign the enrollment agreement before they are enrolled.

CREDIT ACCEPTANCE AND TRANSFER

Regarding authentications and validations:

The University conducts a process of content recognition only among graduate programs which serves to standardize or validate studies. Recognition of content may require examinations to verify previous knowledge on certain subjects. The University only convalidates or authenticates content only when it has been completely standardized.

The entire process requires legalized and original documentation.

Regulations on Subject Convalidations due to Transfer

- The transfer student is one who has passed subjects with A or B grades at an accredited institution in Puerto Rico or abroad.
- The student requesting a transfer must comply with all the requirements for admission.
- Courses that were taken and passed more than ten years ago will not be convalidated. Courses that are 10 years old or less can be convalidated as long as the course content has not changed significantly.
- The courses must have an equal or greater amount of credits, which description is equivalent to the course descriptions of UNIB. Those courses whose amount of credits is less than the amount of credits in UNIB, should be carefully evaluated and will be the responsibility of the academic dean to admit the same.
- Subjects with an S or P grading will not be convalidated.
- Subjects by work experience will not be convalidated.
- It will be the student's responsibility to present the University's catalog where they studied their subjects, in those cases where it is not accessible via the Internet.
- If the student has taken courses in more than one academic institution, each transcript will be independently evaluated.
- Up to 50% of the credits from the Master and Doctorates from another institution can be convalidated.
- Only subjects from the same level will be convalidated.
- The convalidated credits are permanently included in the academic record, but are not used to calculate the student's grade point average.
- The Academic Board reserves the right to convalidate the subjects under conditions it deems exceptional.

ACCEPTANCE OF CREDIT TRANSFER STATEMENT

Acceptance of academic credit transference is determined by the receiving institution.

FINANCIAL INFORMATION

COSTS AND COST POLICIES

COSTS	
Description (The University understands costs as the set of costs associated with the enrollment and the student's academic life development, which payment concedes to them rights and obligations).	Total Program Cost
Costs (or fees) for the masters and doctorates. This amount may be payable according to the facilities made available by the university through its installment payment programs. The prices for our programs are overall and not by credit.	Doctorates \$18,800.00 Master's Degree \$10,500.00
SCHOLARSHIPS An Evaluation Committee will consider the applicant's suitability according to the provided background, academic and professional dossier, personal and family economic incomes and the social/family conditions.	(\$0.00)
Total to be paid by the student for the program cost.	\$0.00
Charges due to administrative services.	\$35.00 (each payment)
Monthly amounts due to administrative charges.	\$0.00
Total of administrative charges	\$0.00
Admission Fee (is paid at the time of applying for admission).	\$50.00
Enrollment Fee This amount includes the program registration fees for enrollment, technical support, delivery of material and access to the Virtual Campus (it is paid after having signed the Student Agreement, with the Virtual Campus not being available until the fee has been paid).	\$450.00
Grand Total	\$0.00
OTHER CHARGES	
Diploma*	\$200.00
Credit Transcription*	\$10.00
Authentication*	\$200.00
Extensions* The study extension refers to the additional academic duration against the originally projected duration for each program that the student applied for in order to complete their program. Original duration: Master: 25 months Doctorate: 60 months	Doctorate \$750.00 Master \$500.00 (Costs by semester)
*Charges for delivery (if applicable). This costs are subject to change.	
Payment Methods The student has the option of paying the total of their studies when they begin, or you may use a payment plan for which they will require a bank account or credit card to make monthly debits. For these purposes, they must sign the Payment Authorization and deliver it via email or certified mail to the University. The Payment Authorization will only include the seal and signature of the Dean of Administration and Finances.	

Relating to the Costs

- The values quoted in the table are the same for any student whether they reside in Puerto Rico or not. Nevertheless, the program's final price will depend on the amount granted for the scholarship.

- The University reserves the right to make changes to the costs concerning the tuition. These values will be publicly informed to the applicants and students through the means for these purposes and shall not affect those students who have already begun their studies, presenting no interruptions for them.
- All students applying for or who are affected by an interruption in their studies for any reason, including non-payment, (partial withdrawal), but not limited to this, will not be able to continue using the Virtual Campus or the teaching resources, nor any virtual infrastructure of the University, during their partial withdrawal.
- Other charges due to specific or special concepts shall be notified 30 days in advance.
- The cost of textbooks is included in the total program cost.
- All charges will be made in advance or on the same day that the process begins, or based on the date stipulated on the Payment Plan.
- Given that the cost is for the entire program, there is no discount for convalidated programs.

CANCELLATION AND REFUND POLICY

The student cancels their enrollment when they requests total withdrawal from the program. To do so, they must communicate their decision by means of a letter that can be sent by email or postal mail to the Student Affairs office.

Students who explicitly state their decision to withdraw from the program and disassociate themselves from the university, arguing deception, fraud, falsehood or similar circumstances by the institution, officials or tutors, are permanently withdrawn without the option of reinstatement, readmission or return, since it is understood that their decision is final.

REIMBURSEMENT POLICY

The Universidad Internacional Iberoamericana (UNIB) will proceed in the following manner when issuing reimbursements.

- 100% of the program cost (not including the tuition) when the total withdrawal is requested before starting the program.
- 75% of the program cost (not including the tuition) when the total withdrawal is requested during the first week of starting the program.
- 50% of the program cost (not including the tuition) when the total withdrawal is requested during the second week of starting the program.

Any refund shall be made within a period of no more than 30 days after requested.

The denial of recognition or homologation of the degree granted by UNIB by foreign authorities outside Puerto Rico and/or the United States, is not cause for reimbursement of the amount paid for the studies.

FINANCIAL AID

SCHOLARSHIP

An Evaluation Committee will consider the applicant's suitability according to the provided background, academic and professional dossier, personal and family economic incomes and the social/family conditions.

Scholarship Application

Candidates who, having applied for a scholarship for a particular program, receive the admissions certificate to the requested program and are notified of being awarded the corresponding scholarship, will have a their enrollment reserved for 6 months from the time of notification by the Admissions Department of acceptance to the program. If the complete documentation required for completing the registration process is not submitted within said allotted time, the applicant will be withdrawn from the process.

ON ACADEMIC LIFE

Academic Life is the time during which a student has an active status. The sum of the periods in which they are in this status should not be excluded to the duration of the studies program which they are studying, with the possibility of having a one year extension divided into two extensions. The Academic Life's maximum number is stipulated by the program's duration. Academic life is recorded as of the official date of enrollment at the University until the delivery date of the final work required for graduation.

Upon commencing their academic life:

- The student enters a study program following the requirements for admission to the university and meets the requirements of the program that they choose.
- The student has access to information about their curriculum and timetable through the virtual environment (virtual campus). The student performs their studies with the constancy of having the skills and knowledge and technical resources to carry out a distance education.
- Students provide all required documentation and sign all required documents.
- The student studies the subjects following the studies programming. They will receive access to the Virtual Campus and will also be receiving printed material as they advance through the subjects.
- The student is considered an active learner at all times, except when other events occur that lead to the states of "withdrawn", "thesis student" and "graduate". The state of the student may vary according to the rules of the university.
- In the event that the Educational Program and/or Schedule of their studies is or are modified, the University will honor the Study Plan in use at the time of enrollment until two years after the nominal date that corresponds to the term, calculated from the day the document is signed. The schedule of their studies can be altered as long as the student is the main beneficiary.

- The University's program durations are projected for twenty-four (24) to twenty-five (25) months. In the case of the doctorates, the duration of the doctoral programs is projected to last 60 to 63 months (depending on the doctorate).
- Every student beginning their first term of a program must perform and successfully complete the required socialization activities for distance learning.
- Every student will have information on the professors that impart their study program.

Relating to internships:

- In the case that an internship is required, they will be approved and supervised based on the University's Internship Manual.

Relating to the regulations:

- Every student has the right to appeal on any University standard by asking for its exception or interpretation. In this case, the student should write to the Department Director, who will submit it to an evaluation under the Department Advisories and the University board. The subject will be handled by the Senate and will be resolved by said body. The Director will notify the student and the Rectory will notify all those involved and/or affected by any type of resolution. The student must make an appeal within a period of no less than 60 working days before the regulation affects them. The Senate will issue a resolution within a period of 15 working days after having received the notification. The resolution will be filed in the Student Record.

Program and subject evaluations

The evaluation of the subjects of all programs is carried out from three of the evaluation tools defined in the previous paragraph to combine both subjective and objective techniques, and so be able to evaluate different aspects (knowledge, attitudes and skills), and integrate different cognitive styles.

In addition, some programs may include classroom evaluations at the University or controlled by a supervisor.

The final grade of the academic programs is derived from the deliberation of the credits from each subject and the Master's thesis.

Relating to the Master's Thesis

The Master's Thesis is the final project (FP) of the master's program.

To begin the thesis development, the student must have completed 66% of the program's credit.

The Master's Thesis may not be defended before completing and passing all the subjects.

The standards set forth in the Guidelines for Master's Thesis are located in the Virtual Campus. These guidelines have been designed to offer the necessary guide in the Final Project (FP) entire elaboration process.

The student will carry out their oral defense in person in the installations of the Universidad Internacional Iberoamericana. Those students not living in Puerto Rico may carry out their defense via Skype or via videoconference using guaranteed technical and academic means.

In relation to the presented thesis document and the defense carried out, the thesis board:

1. Will evaluate the work presented by the student.
2. This may require that the student make changes, improvements and/or corrections when formal and methodological aspects need to be improved.
3. May reject the presented thesis before grave situations, such as plagiarism, and demand the student to begin a new thesis following the Thesis Standards in the Institution.

The minimum grade for passing the thesis is B = 80% or a GPA of 2.50 to 3.49 and 7.0 to 8.5 in the European system.

All student appeals must be made following the appeal procedures stipulated, bearing in mind that this must take place no than 10 business days after receiving the grade for the Master's Thesis. The University will direct an investigation that will handle the appeal. This process should take no more than a month, and has two possible results: sustaining or revising the grade.

If the grade is sustained, the Thesis Act Registry closes. If the grade is revised, it will be revised with a new grade being received.

Any impact on this process will be taken up by the Program Director leaving a written record of the proceedings and actions.

Relating to the Doctoral Thesis

The Doctoral Thesis will begin once the student has completed Research Phase III.

The standards set forth in the Guidelines for Doctoral Thesis are located in the Doctoral Thesis Manual.

The student will carry out their oral defense in person in the installations of the Universidad Internacional Iberoamericana. Those students not living in Puerto Rico may carry out their defense via Skype or via videoconference using guaranteed technical and academic means.

In relation to the presented thesis document and the defense carried out, the thesis board:

1. Will evaluate the work presented by the student.
2. This may require that the student make changes, improvements and/or corrections when formal and methodological aspects need to be improved.
3. May reject the presented thesis before grave situations, such as plagiarism, and demand the student to begin a new thesis following the Thesis Standards in the Institution.

The possible grades for the dissertation are:

Quantitative Values			Value Qualitative
0-10	Grade Point Average (GPA)	%	
10-8.6	4.00 – 3.50.	100-90	A
8.5-7.0	3.49 – 2.50.	89-80	B
6.9-4.5	2.49 – 1.60.	79-70	C
4.4-4.0	1.59 – 0.80.	69-50	D
0	0.79 – 0.00.	49-0	F

All student appeals must be made following the appeal procedures stipulated, bearing in mind that this must take place no than 10 business days after receiving the grade for the Doctoral Dissertation. The University will direct an investigation that will handle the appeal. This process should take no more than a month, and has two possible results: sustaining or revising the grade.

If the grade is kept, the Thesis Act Registry closes. If the grade is revised, it will be revised with a new grade being received.

Any impact on this process will be taken up by the Doctoral Director leaving a written record of the proceedings and actions.

HOURLY-CREDIT POLICIES OF THE INSTITUTION

Each student will progress in their studies according to the academic program. The amount of time that must be devoted to the studying and completing each of the subjects varies according to the appropriations that have been assigned to it. UNIB will measure the credit courses by the learning outcomes achieved through 45 hours of student work for one unit (one credit hour). One unit is 15 hours of academic engagement and 30 hours of preparation. This formula is typically referred to as a Carnegie unit.

Student work includes direct or indirect Faculty instruction. On one hand, academic engagement includes the following activities:

Directed and supervised activities	Participation in forum activities
	Correction of exercises.
	Tutoring (individual-group)
Assessment tasks	Tests

And on the other hand, preparation is related to the following activities:

Autonomous activities	Watching and working with virtual exhibition sessions
	Preparation of forum activities
	Personal study of the contents and readings
	Development of group or individual work
	Performance of Practical Activities
	Performance of self-evaluation and reflection activities

Therefore, a 3 credit hour course 45 hours of academic engagement and 90 hours of preparation.

The number of credits attributed to each subject is directly related to the estimated time that the student must dedicate to develop the skills, acquire the knowledge and achieve the learning competencies defined through the implementation of the learning activities planned for that purpose. Based on this premise, it is expected that the time of study of a subject of 3 credits is between 4 and 6 weeks depending on its characteristics.

ACADEMIC GRADING POLICIES

The UNIB grading policy is based on the Grade Point Average (GPA) used in Puerto Rican and American universities:

The moment the student is enrolled in an educational program, the curriculum subjects of the study program to be taken are recorded for the student. The credits registered are the total for the program and the student must comply with the term of duration of academic life.

The grades will be expressed in grades A, B, C, D and F within the GPA scale. A course is passed with a minimum grade of B within the GPA scale.

At the end of the studies, the student receives a final grading on the program that is calculated on the basis of a weighted average of the scores obtained in the subjects and in the Master Thesis.

Every grade must be justified by the professor and the student can appeal in writing for a revision if they are not satisfied with the final grade obtained in the subject or some of the activities that makeup the evaluation. For it, the student has 10 business days after the grade is published. The following is a description of the **Grade Revision Procedure**:

1. In the first place, the message must be directed at the subject professor and must ask for the revision of the final grades obtained in the subject or in any of the evaluation activities that comprise it. In this same message, the student should explain the reasons for which the grade is not correct and justify their position in this regard.
The professor then has 10 business days, counting from the moment from when they receive the request from the student, to perform the review according to the arguments put forward by them and give an answer.
2. If the professor believes that the claim is not applicable, the student may request a new revision to the program director (Doctoral Director for doctoral students), who in turn must give an answer within a maximum period of 10 business days.
3. In the case of the Master, if the program director also dismisses the claim, the student, in a last instance, can submit it to the department director. In the case of the doctorates the message must be directed at the Doctoral Director.
4. The Department Director (or Doctoral Program Director), will answer the student in a maximum time of 20 business days. The decision arising will be final and firm, by agreement between the parties involved or simple from a majority.

Students are entitled to know the grade of an evaluation, as well as correction methods before undergoing a reassessment of the same nature in a subject.

Any special activities included in a program of study will be announced in advance to the student.

GRADING SYSTEM

The student receives a detailed feedback on their performance in the evaluation tests carried out, and for the grading of said evaluations the university uses a system equivalent to the GPA method ("Grade Point Average"). According to the system in UNIB, the grades are expressed in letters A, B, C, D or F.

To obtain the program's GPA: The points for each subject are multiplied by the number of credits or hours for that subject, added together, and divided by the total number of credits or hours. The minimal grade at the end of the whole program should be a B (2.50 - 3.49 GPA).

The following shows the equivalence between the values of UNIB quantitative and qualitative grades. The following expresses the GPA method equivalence:

Quantitative Values			Value Qualitative
0-10	Grade Point Average (GPA)	%	
10-8.6	4.00 – 3.50.	100-90	A
8.5-7.0	3.49 – 2.50.	89-80	B
6.9-4.5	2.49 – 1.60.	79-70	C
4.4-4.0	1.59 – 0.80.	69-50	D
0	0.79 – 0.00.	49-0	F

With the goal of ensuring that the grades are awarded with the fairness and consistency, especially in the case of subjective assessment techniques, all the programs have evaluation criteria that all professors must apply using rubrics. These evaluation criteria (rubrics) vary depending on the program and the academic task that is being assessed.

The evaluation system for each subject is explain in a complete and clear manner within the document titled "Subject Evaluation", which is available in the section "Evaluation" of the subject's virtual classroom.

SUBJECT RETAKE

During the term in which the student is enrolled in a course, as mentioned above, they must perform three evaluation activities throughout the learning process (a formative evaluation) and another at the end (summative evaluation).

In those cases in which the student receives a grade lower than 7/10 (B) after their first exam call, they will have two opportunities to pass the subject through resit activities 1 and 2.

The student accesses the first resit within the appropriate section enabled on the campus, where the access to the evaluation tools is displayed.

If they fail again, they must perform the second resit, whose maximum obtainable score is 8.5 points, which means that their GPA will be affected. If the student fails resit 2, they must enroll in the subject again.

TEMPORARY LEAVE OF STUDIES

Some students may receive a temporary leave of study. This leave is only authorized in the following cases:

- Sickness - Leave medical reason that indicates inability to continue with the studies for a certain period of time.
- Maternity or paternity.
- Extraordinary professional Commission.
- Military leave.

The student is entitled to a maximum of six (6) months of temporary leave during the course of his/her studies, which will be calculated taking into account any reason for leave.

GRADUATION REQUIREMENTS

Each program has its own minimum requirements for graduation. However, the following is always expected and may be required by the University in case of non-compliance.

- Complying with all administrative requirements of the University.
 - Up-to-date documentation, no material yielded in loan or non-legal possession of proprietary software, and not be affected by administrative or internal procedures, such as misuse of computer resources received from the University.
- Complying with all the financial requirements of the enrolled program and the University.
 - Absence of financial debts with the University, not being affected by a fiscal reporting process or similar, and to have paid the rates of degree and other rights and be up-to-date in the payment of fees or program costs.
 - Having paid the University's graduation and diploma issuance fees.
- Meeting all academic curriculum requirements.
 - Having passed the entire educational program and the examinations required to obtain the degree or certification and the favorable reports required of the respective committees, if any, while not having been accused of plagiarism or questionable methods in obtaining the degree or certification and having the final work approved.
 - Complying with the specific regulations in this regard.
 - Having complied with the requirements of the duration of University Life.
 - Having complied with the requirements of the duration of Academic Life.
- Comply with the established length of stay for each program:

- The master's program will have a minimum period of 1 (one) academic year and a half (12 months for those who study without an interval).
- The doctoral program will have a minimum period of 30 months for students who study without time intervals.

SUPERVISED EXAMS (PROCTORING)

Online Evaluation Systems

For the online evaluation system basically there are three tools that minimize the risk of false identity when performing an activity:

- Access with user and password.
- Traceability indicators.
- Controls using videoconference: asynchronous and synchronous.

Access with user and password.

All student enrolled is assigned an account of access through the PANAL system, which is the entry via to the Moodle platform for the program. The account includes a unique user name for each student and a password that the student must change as desired.

Indicators of traceability

Once the test is delivered there are a series of indicators that alert us of possible fraud, for example:

- Grades that do not correspond with the trajectory followed by the student throughout the Program.
- Changes in the drafting styling compared to other submissions.
- Substantial variations in the response time.
- Variations in the IP address of the computer that has handed in the exam and its relationship with the grades (This aspect is only valid for static IP's, as the dynamics will always be different for the same user).

These indicators do not validate cases of fraud, but they alert professors to require the student in videoconference or in a face to face meeting the answers given, in order to check the veracity.

Verification Procedure for Student Identification

Controls using videoconference: asynchronous and synchronous

UNIB has different controls systems to identify students through videoconferencing, in particular:

- **Asynchronous monitoring system**, where the student is recorded while performing the test and upon delivery the recordings are reviewed to verify the identity of the student and that the norms required for the activity were met.
- **Synchronous monitoring system** through which teachers can request the student to make a videoconference, at any moment during the test.

In the asynchronous monitoring system, the student is asked to conduct the evaluation in front of a Webcam that records the completion of the test.

Supervised Test

This test will be supervised by the academic personnel to ensure that you are _____

Please follow the instructions below:

Have an identification document that has a photo.	<input type="button" value="Accept"/>
Activate your webcam by clicking "Start Camera" and make sure that you have audio.	<input type="button" value="Start Camera"/>
Show your ID in the webcam, pulse the button start recording and say your name loudly. Make sure that your ID can be seen.	<input type="button" value="Start recording"/>
When you finish pulse "Save".	<input type="button" value="Save"/>
Start the test	<input type="button" value="Start test"/>

Initially the student must show in front of the webcam documentation of personal identification.

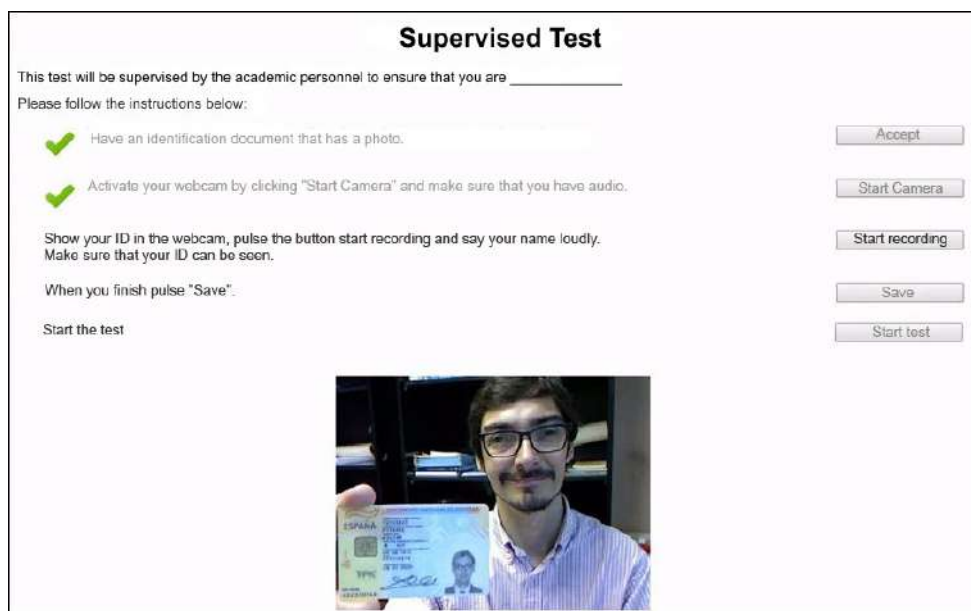


Figura 50: Starting the video-supervision system.

After this first phase, after completing all the steps, the test begins.

The supervisor records the outcome of the monitoring in corresponding section and adds the any necessary comments depending on the result.

If any incident is found, an alert is issued to the Director of the Program and the main professor of the subject to review the case and take the appropriate corrective actions.

The validity of the qualification in the evaluation is conditional to the results of the monitoring.

In the current version of asynchronous monitoring system is established the performance of a minimum of three monitored reviews during the development of the program:

- The first one, when the student has exceeded 15% of the program credits. In order to provide a period of familiarization with the virtual campus platform.
- The second one, when the student has exceeded 45% of the program credits.
- The third one, when the student has exceeded 70% of the program credits.

In the case of the Synchronous Monitoring System, the student may be required while performing the test to initiate a not programmed supervision, by activating a channel of communication via video-conference with the monitoring personnel of UNIB.

Both monitoring systems by videoconference - asynchronous and synchronous - require: from the technical point of view, to count with devices for audiovisual recording (video [webcam] and audio), and from the legal point of view, to ensure that the registration of the information meets the regulated by the *Family Educational Rights and Privacy Act of 1974, as amended* (FERPA law), concerning the terms of privacy and data protection. The student is informed during his admission process and it is specified in the document that the student completes and signs in his/her enrollment.

STUDENT SERVICES

The Student Affairs services is responsible for providing guidance and to the student in benefit of their comprehensive education in order to enhance their academic development. The main responsibilities of Student Affairs is the variables that may affect the student's performance and satisfaction.

During the guidance process, the Student Affairs officer is responsible of providing a follow-up to the student's academic record from their tuitions, changes, re-admissions and collaboration in retaining the students.

REGISTRAR SERVICES

The Registrar's Office is established and operates under the Dean of Student Affairs.

Description of services offered at a distance by the Registrar Office:

- Collects all the information of the student's academic history from the beginning to the end of their studies. Administers and controls the enrollment information of active, withdrawn, and terminated students from all academic programs.

As a complement to the Registrar's role, distance services related to Academic Monitoring are mentioned.

COUNSELING PROGRAM DESCRIPTION

Counseling Services

The Counseling service is offered to our students through a virtual and face-to-face manner with a professional, academically prepared Counselor with vast experience in the field. They will seek to offer academic and individual support to students. The development and welfare of the student is encouraged through this service, while working on their educational and vocational planning. Our focus is centered in the integral training of the individual so as to encourage the development of intellectual, social and emotional capacities.

- **Academic Counseling:** The academic counseling assesses those interests, abilities, and limitations that the student may present. This is to establish a support plan and corresponding action.

Educational planning seeks for the student to successfully achieve their goals.

- **Individual Counseling:** There are situations that may affect the student, which is why we offer the student an opportunity to express said concerns that interfere with their performance.

The student's needs are assessed and provided with alternatives for action through this service. Confidentiality is maintained at all times during the process. If an emergency action is required, the necessary protocol will be provided.

Those students who need professional counseling services may request them through the PANAL or by contacting us via email consejeria@unib.org. The student may also communicate with the university via telephone and request an appointment. The counseling services will not be limited to emails but also include –if necessary- the use of various technological tools for virtual communication and support for face-to-face contact. Individual counseling services are confidential to care for the counselor and student privilege.

Reasonable accommodation

The professional Counselor will address any claim of reasonable accommodation from any candidate that require special services. Those students with special needs must apply for reasonable accommodation to the Professional Counselor, who will evaluate and advise the steps that must be follow in order to receive this accommodation.

TECHNICAL SUPPORT

All of the students from the programs of the Universidad Internacional Iberoamericana receive the necessary instructions to study their courses at the beginning of the program, covering both the acquisition of skills in the use and management of information resources as well as the integration of other students and the university community.

In case the student requires help from Technical Support, the service can be accessed through the Virtual Campus in an icon of the same name. The solutions to the most common problems are

presented here. If the student cannot resolve their problem, they may contact Technical Support through the contact form and they will be contacted in a short period of time.

The student may also visit the UNIB facilities on **Monday to Fridays from 8:00 a.m. to 5:00 p.m.**, where a technician may help the student with their issues.

In the Virtual Campus, the student can access an icon called Technical Support. In this section they will find solutions to the most common problems. If the student is unable to solve the problem, they may contact Technical Support through the Contact Form, and after short period of time, will be contacted to resolve their issue.

LIBRARY SERVICES

About the Library

Location / Access / Population

UNIB Virtual Campus The library can be accessed through the Internet for exclusive use by the Academic Community and is designed with the philosophy to offer a 24/7 service.

The Library relies on a professional staff with a great deal of experience in teaching, knowledge, skills and abilities in information management and technology to train students and professors as curricular and scientific support. It also possesses technological, social, linguistic (English and Spanish) skills and multidisciplinary knowledge.

UNIB Library Philosophy

UNIB's library philosophy is to support, promote and contribute the Open Access movement through its services of information and knowledge. Therefore, we unite and use the infinity of existing projects on the web accessible in complete texts without restrictions and of free dissemination. We believe that for scientific knowledge to reach its maximum development, it must be communicated through the tools and traditional and non-traditional formats that allow access that is universal, free and in benefit of humanity.

With the purpose of extending the offer of search and management of information, **UNIB has also subscribed to the consultation service to data bases of bibliographical information of complete texts, e-books and discovery service of EBSCO Information Services.**

The Virtual Library of the Universidad Internacional Iberoamericana is an academic portal which function will be to become the best virtual space of information services and academic research that promotes international academic learning and contributes to achieving the institutional and academic objectives of our University through:

1. Offering excellence and quality in all library services.
2. Providing, maintaining and developing updated digital collections pertinent to the academic programs.

3. Creating a community of learning, teaching, research and academic and scientific innovation.
4. Offering excellent information services through the Internet or diverse electronic means to the academic community it serves, without limitations in time or space.
5. Facilitating access to sources of updated, scientific, multi-sector, free and pay access, thereby satisfying the needs of our students and supporting the Faculty.
6. Preserving, organizing and transmitting knowledge for future generations.
7. Training users in the effective skills of searching, managing and using information.

Objectives

General Objective

- Develop an articulated model for a bibliographic service and digital classroom that can be applied and used in various programs of study related to the online teaching of the Virtual Campus.

Specific Objectives.

- Develop a tutorial module on the use and handling of the entire bibliographic service.
- Design an online library with the current means of virtual support and with a real exploration of its potential to support student learning and part of the learning itself.
- Analyze the digital development of the basic bibliography of each subject and contribute to their digital equivalents.
- Search for sources of free "generic" information to replace websites that require payment.
- Provide useful and evaluated information on the sites where they can access the digital acquisition of books and magazines.
- Establish agreements with classroom libraries.
- Create a librarian catalog and documentary fund that allows autonomy of access based on an articulated structuring of the information.

Librarian

- Is the person responsible for the monitoring the Virtual Library's information management.
- Will work in the information that is the vital resource, a raw material which is the support source in the student's knowledge management.
- 24-7 availability via the Virtual Campus.
- Must adapt to the new technologies to meet the requirements of the modern society.

Basic Library Areas and Services

1. Librarian Consultation

This area offers the services known by virtual reference where you interact with the librarian synchronically or asynchronously for consultation. For this, web forms, frequently asked questions, e-mail, chat or videoconference are used when necessary and by mutual agreement.

2. Digital Catalog

The virtual library is a digital platform that attempts to reproduce and improve the behavior of a geographic studies center with all the relevant administrative services, lecture rooms, meeting places, offices and the library itself. Its purpose is not to replace these with an onsite system of teaching-learning for a complete online system, but various phases and models can be given, from a full on-site classroom, to a mixed system where each component has a different and specific importance to it (onsite/online) including the completely online offer.

What UNIB attempts to do is, in this new situation of a virtual campus, reproduce all the interactions required to successfully obtain a teaching-learning process. This provides an excellent opportunity to not limit learning to slavishly imitating the objectives and results of the teaching-learning classroom but to qualify for more efficient goals and fruitful educational innovations.

The University, through its online services from a Virtual Campus, will provide access to an online library and will have free access to its documentary resources for any student.

The benefits of the computer medium are in direct relation to the number of users that it serves, supporting a population of 8,000 students in this case. The online library provides its documentary resources in several types of classified access in multiple sites to facilitate its availability, such as:

- Notes by subject;
- News and highlights from the Campus;
- Supplementary material by subject; and,
- Transversal material in a program.

The type of documentation it contains is:

- News;
- Defended thesis;
- Links to places of interest;
- Links to documents of interest; and,
- Discussion Forums.

All the online material is free to use and disclose, and may be accessed and downloaded computationally by active students.

The Virtual Campus offers a system to search for information that, in addition to searching for information on sites and documents, searches the entire virtual campus, including forums, chats, and message.

3. Assigned Readings

In this area, different types of pertinent readings for each program are collected and stored, having been selected by the faculty and the librarian.

4. Scientific Magazines

This is a collection of links and services (of paid or open access) of professional multidisciplinary or thematic magazines.

5. Portals and Library Search Engines

Area where you will find links to Internet search services and web portals for recognized libraries.

6. Thesis and Dissertations

This is a collection of links and services where theses, dissertations, and documents of multidisciplinary or thematic research are stored.

7. Electronic Consultation

Collection of documents, internet links, electronic books and general or thematic audiovisual materials are used by the community as reference.

8. User Training

Services organized to train users in the services of database search for scientific magazines, documents, theses, style manuals, among other resources like research backup tools. In addition, it provides training in the skills of information management (search, selection, analysis, organization of information). Various forms of training (fact sheets, presentations and audiovisual resources) are used.

9. EBSCO Database

Description of the resources offered:

- **Academic Search Complete**

Academic Search Complete is the most complete and useful database for complete multidisciplinary books of its kind. It includes more than 9,100 magazine titles and complete text books and around 7,900 arbitrary publications while offering more indexes and resumes of more than 13,690 periodic and diverse publications, which include monographies, reports and conferences. The data base presents PDF content that dates back to 1887. It includes

information in the areas of: Basic Sciences, Engineering, Architecture and Technology, Agro and Sea Sciences, Education, Social Science, Humanities and more.

- **Business Source Complete**

Business Source Complete contains the main collection of complete texts and bibliographic registries of the most prestigious and used academic publications in the administrative and economic areas.

This data base includes complete texts for more than 3,850 magazines of which 2,006 are arbitrary. This data base also includes complete texts for 917 books, 2,530 market research reports, and 1,446 reports on the economic performance of countries, amongst others.

- **Education Source**

A great research for the study of education, this bibliographic and complete text data base covers scientific research and the information to satisfy the education needs of students, professionals and political officials. Education Source was developed based on a fusion of data bases from EBSCO and H.W. Wilson, and includes many unique sources that were not available previously. This source of information offers the biggest and most complete collection in the world of educational publications for complete books, and covers an ample international range of magazines, monographies, annuals and much more. Offers bibliographic registers for thousands of publications and complete texts for more than 1,800 magazine titles, more than 50 books, monographies and hundreds of conference reports.

- **Premier Academic Source**

It is a multidisciplinary database with information from prestigious periodicals produced in the Spanish language. This is a collection of high academic relevance that provides information in all areas of knowledge, namely, the social sciences, humanities, education, computer science, engineering, linguistics, art and literature, medical sciences, ethnic studies and law.

The more than 850 periodicals and 30 books in full text, included in the *Fuente Académica*, are produced by the publishers of the most prestigious universities and research centers of the Hispanic world and represent the most important results of the region's research efforts. Amongst other prestigious periodical publications there appears: *Annual of International Law* (University of Navarra), *APORTES: Mexican Magazine about the Studies of the Pacific Basin* (University of Colima), *CEMLA Bulletin* (Latin American Monetary Studies Center), *Veterinary Sciences* (University of Pampa), *Communication and Society* (University of Guadalajara), *Literature Workbooks* (Pontifical University Javeriana-Colombia), *Social Sciences Journal* (FLACSO), *Perspectives on Policy, the Economy and Management* (University of Chile), *Development Problems: Revista Latinoamericana de Economía* (Latinamerican Journal of Economy) (Autonomous University of Mexico), *Psykhe* (Catholic Pontifical University of Chile), *Accounting and Finance Magazine* (University of Sao Paulo), *International Journal of Social Security* (Blackwell Publishing), *CEPAL Magazine* (United Nations Publications), amongst others.

- **GreenFile**

GreenFILE offers information from reliable research on all of the aspects of human impact in the environment. It counts upon a collection of titles from such sources as academic, governmental, and general interests on global warming, ecological construction, sustainable agriculture pollution, renewable energy, recycling, and many more. This database provides indexing and

resumes of more than 384,000 records, in addition to open access to full text for more than 4,700 records.

- **Library Information Science & Technology Abstracts**

(LISTA) indexes more than 560 fundamental publications, approximately 50 primary publications and around 125 selected publications, apart from books, research paper and reports. The topic coverage includes librarianship, classifications, cataloging, bibliometrics, collection of online information, information management, etc. The database coverage goes back to the mid-1960s.

INSTITUTIONAL REGULATIONS

THE STANDARD OF SATISFACTORY ACADEMIC PROGRESS

The standard of academic progress contains the evaluation criteria to determine the student's academic progress. In addition, this is the upkeep policy to ensure that the student can complete the degree.

The standard has three principal components:

- Number of credits approved each year.
- Accumulated academic index.
- Maximum time period to obtain the degree based on the program.

Successful academic progress is considered as:

- Having approved at least 40% of the credits attempted during the first academic year.
- Have reached the required academic index for the total number of accumulated completed credits (B= 80%).

Any student who fails to comply with the requirements of the main components during their first academic year will not achieve satisfactory academic progress, by which they will be subject to a period of academic probation.

Student Evaluation during Academic Probation

The student with an academic probation status will be evaluated in all components of their academic progress during the 6 month term. If they succeed in obtaining an academic average of 80% (7) and a progress of (50%) during said term, they shall be deemed as being in compliance with this standard. In those cases where the student does not achieve a satisfactory academic progress, they will be given a second academic probation of 6 months. The student on academic probation will be evaluated in all components of their academic progress. If they succeed in obtaining an academic average of 80% (7) and a progress of (60%) during said term, they shall be deemed as being in compliance with this standard.

If the student does not achieve an academic satisfaction progress during their second academic probation period, they will have the right to request a first extension on their academic time for an additional cost and will be evaluated in all components of their academic progress during the

6 month term. If they succeed in obtaining an academic average of 80% (7) and a progress of (80%) during said term, they shall be deemed as being in compliance with this standard. If the student does not achieve an academic satisfaction progress, they will be given a second extension on their academic time. If they succeed in obtaining an academic average of 80% (7) and a progress of (100%) during said term, they shall be deemed as being in compliance with this standard.

- Completed all of the subject credits within the set period.
- Completed the academic degree within the recommended period.

The Satisfactory Academic Progress (S.A.P.) depends on all the components together, not each one in particular.

The convalidated credits are not taken into consideration when computing the grade point average. The student should have passed 50% of all credits tested.

Purpose:

The purpose for the Standard of Academic Progress is to ensure that the student can complete the degree at the end of the period as required by the institution.

Objectives:

- Increase student retention.
- Increase graduation rate.

Evaluation Calls:

The student has three chances for passing a test (an ordinary test and two resits) to achieve the Standard of Satisfactory Academic Progress.

Personnel Responsible for the Standard of Academic Progress

The Standard of Satisfactory Academic Progress will be under the charge of the Dean of Student Affairs, the Academic Dean and the Professional Counselor.

STANDARD FOR COMPLETING THE DEGREE

All students must complete their academic degree in or before the maximum time period established for the program.

STANDARD FOR ISSUING POSTHUMOUS DIPLOMAS

The University may grant diplomas and certifications to deceased graduates who passed the entire program and fulfilled all the requirements for such purpose, and who did not received their diploma before their death.

STANDARDS OF BEHAVIOR

Regarding the academic performance of a student at the University:

- Must make an effort to search for and express the truth while respecting the discrepancies.
- Must actively participate in the Virtual Campus and look to participate in onsite integration activities if there were any.
- Must maintain grades that correspond with the demands of the University.
- Must reply to the follow petitions conducted by the tutor to verify the student's progress.
- Their withdrawal from the University may be requested if they exceed the academic periods as indicated in the standard.
- Must conserve, enrich and disseminate the University's values and those of the country.

STANDARDS OF ONLINE PERFORMANCE

Regarding the academic achievement of a student at the University:

- Pass all evaluated activities and subjects with rectitude and honorability.
- Maintain an adequate relation between course and approved credits versus the maximum period for completing the program.
- May appeal any grade obtained.
- The student is responsible for the content of each of the documents created and/or those stating his/her name.

STANDARD ON CLASS ATTENDANCE AND INTERACTION

Regarding the attendance and interaction in classes of a student at the University:

- The student will participate and interact in the subject and/or Virtual Campus (forums and other activities) as specified in the Subject Evaluation and those other evaluations as indicated.
- The student's participation and interaction may be evaluated in different ways, for example: assessment and number of messages sent via the forums, virtual campus activity, etc.
- This information is detailed in the Subject Rubric.

STANDARD RELATED TO ACADEMIC HONESTY

- The student may not incur in the copying, plagiarism or falsification of documents, information or data.
- The student shall not incur in providing false information, change of identity or impersonating themselves or someone else.

STANDARD FOR ACADEMIC CONTROL AND DISCIPLINE

Infractions are understood as any conduct that violates the exercise of rights and duties of students. Infractions are classified according to their level as less severe, severe and very severe. This level will be determined by the Academic Control and Disciplinary Committee.

The student under investigation is considered innocent until the final resolution from the Disciplinary Committee

When professors identify an infraction case carried out in one of their courses, they shall write a report on the situation, including the evidences for the case, and deliver them to the Department Director. They in turn will deliver a notification to the Rector, who activates the Academic Control and Disciplinary Committee. This committee is made up of the following members:

- the Academic Dean.
- the Dean of Student Affairs.
- the Registrar.
- the Professional Counselor.

The Academic Dean presides as president of the committee, who is in charge of solving the case presented before them. If the student is not in agreement, they may appeal said decision within a period of 10 days a of receiving the resolution.

On the types of infractions:

1. Less serious infractions constitute:

- Altering the normal development of any academic activity through the Virtual Campus and/or during University visits.
- Consuming or being under the influence of alcohol and/or narcotic substances when visiting the University.

2. Serious infractions constitute:

- Relapse of a less serious offense.
- Write inappropriate or disrespectful expressions toward members of th University Committee through the Virtual Campus.
- Violate the provisions adopted by the University's authorities.
- Perpetrate malicious acts intended to disrupt the legitimacy of any academic activity through the Virtual Campus.
- Submit altered or false documents.
- Distribute material through the Virtual Campus that may be offensive to the recipient.
- Written expressions through the Virtual campus that damage the University's image, the community's and its members'.
- Intervene in the University's information systems without authorization or use these to intervene into systems outside of the University without authorization. File maliciously false information to the Academic Control and Disciplinary Committee.

- File maliciously false information to the Academic Control and Disciplinary Committee.
- Plagiarize any type of intellectual work by not citing the source it was obtained from, taking others' ideas as their own.
- Enter the university campuses where there is a sanction that would prohibit their entry, provoke disorder or participate in any way, so as to prevent the development of University activities or use of any university unit, and/or hide, damage, or destroy property, documents or instruments of the University, its students, staff or third parties.
- Copying during an exam while whether or not being proctored.

3. **Very serious infractions constitute:**

- Relapse of a serious offense.
- Doctor University documents or of any other nature.
- Perpetrate acts of violence, verbal or written against members of the University community, for example, threats, slander, defamation or interference in the exercise of their rights.
- Use the contents of the volumes for personal benefit or profit.
- Carry weapons on college campuses (not applicable to agents of public order which job requires carrying a weapon), traffic, carry or store drugs or raw materials used to produce them, and misappropriate assets, documents or instruments of the University, a student, or a member of the community.
- Fail to appear on the date and time indicated by a subpoena from the Academic Control and Disciplinary Committee.
- Use the name or logo of the University, its agencies and authorities, without authorization.
- Deny presenting identification when required during a supervised exam through the Virtual Campus.

The Academic Control and Disciplinary Commission may extend or alter this list, without excluding or removing any infringement according to the cases being investigated and prosecuted.

Type of Sanctions:

- Less serious infractions will be sanctioned with one or more of the following:
 - Verbal warning
 - Written warning
- Serious infractions will be sanctioned with one or more of the following:
 - Temporary suspension of participation in the Virtual Campus from all University activities (withdrawn student) from one day to a maximum of four month.
 - Prohibition of entry into the physical facilities and the University's computer services for the sanctioned period. The student in this situation will be considered partial withdrawal.
- Very serious infractions will be sanctioned with one or more of the following:

- Prohibition of entry into the physical facilities and the University's computer services for the sanctioned period (withdrawn student). This level in question will be determined by the Disciplinary and Academic Control Committee.
- Expulsion from the University, which means an indefinite admission prohibition of the same (“permanently withdrawn” student).
- The sanctions will be recorded in the student's academic record.
- The imposition of disciplinary measures outlined above will be in accordance to the mitigating circumstances or aggravating responsibility in each case. Good academic background, prior good conduct, or remedying part or all of the damage done by the infraction can be considered as extenuating circumstances.
- The Academic Control and Disciplinary Committee may, in certain cases, lower the sanction degree in exchange of alternative sanctions which promote the rehabilitation of the student and the benefit of the University community.
- Disciplinary measures will be applied without affecting the exercise of appropriate legal actions according to the law in force in the country. By being a Distance Education University, legal action outside the country or application of international standards are not excluded.
- In the event that false, erroneous or incomplete information has been provided, they will be subject to this procedure if they are students. If a professor contributes false, erroneous or incomplete information, they will be sanctioned with temporary suspension without payment for a period of one academic year. If there is a recurrence, the officer or professor can be dismissed from the University. This investigation will be conducted by the Academic Control and Disciplinary Committee following the same operating procedure.
- In the event that a member of the Academic Control and Disciplinary Committee commits acts that affect the proper performance of the Committee the member shall be expelled from the Committee and the vacancy shall be filled by the Rector. If a professor contributes false, erroneous or incomplete information, they will be sanctioned with temporary suspension without payment for a period of one academic year. If there is a recurrence, the officer or professor can be dismissed from the University. This investigation will be conducted by the Disciplinary Committee following the same operating procedure.

STANDARDS OF BEHAVIOR

Student code of conduct

A University student is considered a person responsible for their ethical, moral and legal actions, and who accept the University's Mission, and all of its standards, regulations, and statutes and as such count with the rights to participate in its academic life.

Regarding the conduct of a student at the University:

- Will make good use of the University's services.
- Will not participate in or involve the University or any third party in any illegal or unlawful act, as well as any act that impact their own, the University's or third parties ethics, morals and/or integrity.

- Will comply with the educational program responsibly.
- Will not provide any false information to the University.
- Will not be able to use their rights or obligations in a wrongful or undue way.
- Will not engage in copying, plagiarism or falsification of documents, information, or data.

MUTUAL RIGHTS AND OBLIGATIONS OF THE INSTITUTION AND STUDENTS

The University promotes the creation, discovery, organization, transmission and management of knowledge from its own diverse tasks and from the reflection processes itself on the application of these same teachings.

The university aims to train people who have a clear understanding and specific understanding of the basic principles of science and technology, with a vision and perspective that integrates natural and social phenomena, and with study, work and research habits to act on their future activities with a strong and secure comprehensive preparation.

The University bases its course of action on the freedom and rights that each person enjoys which are granted by the constitution and laws of the country and the laws and regulations in defense of people worldwide.

The University defines the student, when applying these statutory norms and the policies and University life, as a person that complies satisfactorily with the requirements of admission and has the qualities of a student in accordance with the active regulations regardless sex, race, nationality, religion or political conviction.

Any person defined as a student of the University enjoys freedom and assumes obligations and rights toward the University and the University towards them. In general, a university student must display high and unrestricted respect for the rights of others, excluding all forms of violence or incitement either physically or virtually. The University protects the individuality of opinion and behavior, but does not condone the exclusion of or aggression towards others arising out of individuality.

RIGHTS AND OBLIGATIONS OF THE INSTITUTION WITH STUDENTS

The student is entitled to, and it is the obligation of the University to:

- Provide a solid scientific, technical, professional, humane and supportive education guided by the philosophy of the University.
- Develop in each student a strong resourceful and innovative spirit to produce advances and contribute solutions of direct application in the society and community.
- Encourage the expression of opinion as part of education with a solidarity and communal respect that arises from individual freedom of expression, opinion, and behavior.
- Inform, divulge, and diffuse all information affecting University life especially relating to rules, regulations, and University decisions.
- Inform each person of the personal data contained in their academic records at the University.

- Have known, informed, fair and equitable appeal mechanisms for expressing appeals and petitions.
- Provide mechanisms to be heard by the appropriate authority on any aspect of University life.
- Always support freedom and equal rights, regardless of sex, race, nationality, religion or ideology.
- Provide a process for judging academic violations, which shall be made public along with the sanctions to be imposed.
- Ensure privacy of student information and provide the means for amends.
- The student cannot be deprived of their right of expression while being aware of the consequences of their actions.
- Ensure freedom of assembly and association in the terms accepted by society and its regulations.
- Ensure that discussion with any teacher be in the appropriate terms for a University environment.
- Prevent the use of subjects for research without informed consent.
- Provide academic counseling and monitoring in any university activity accepted or required.
- Ensure an academic load that does not affect physical, mental or cognitive conditions.

RIGHTS AND OBLIGATIONS OF STUDENTS WITH THE INSTITUTION

The fundamental right of the student at the University is to be educated. This right is not limited to formal activities in the classroom, but extends to the interactions and experiences with other members of the university's community. The primary obligation of the student is to exercise this right to their maximum and show a conduct that allows the rest of the members of the university community equal exercise of their rights and the fulfillment of their obligations.

As an obligation of each student and a right of the University, each student must:

- Contribute to their own education and that of others in a cooperative, collaborative and supportive manner giving their best effort to individual or group study.
- Maintain a conduct and attitude in virtual and physical space that is an example of the advancement, excellence and prestige of the University.
- Refrain from participating in acts or situations that may harm or diminish the image of the University without endangering individual freedom for which the student is civilly, administratively and criminally responsible.
- Have respectful interactions with peers and each of the members of the University community.
- Always promote a culture of respect with the natural and social setting in an ethical and responsible manner.
- Accept and follow the rules, regulations and any existing provision of the University.
- It is the responsibility of the prospect to get information to meet the statutory requirements of each country where the profession will be practiced.
- Use University resources for strictly academic purposes and within the philosophy of the University.

- Not commit infringement of regulations, and comply with the sanctions imposed in each case.
- Not provide false or misleading information or induce falsification of information.
- Not take part in activities that university regulations, national or international laws and regulations consider crimes or terrorist activities or of incitement to violence or denigration of any person or organization, or anything else that violates people or society. Students may also not use the means and resources provided and / or used by the University for this purpose.

RIGHTS AND OBLIGATIONS OF THE FACULTY WITH THE STUDENTS

It is the right of each student and obligation of the Faculty, that each student:

- Have a known, informed, fair, and equitable appeal space for any academic event in which the student desires or demands a resolution.
- Be informed of all evaluation mechanisms to which one will be submitted 5 days before the start of each academic activity.
- Be treated with equality.
- Should not be forced to incur any infraction consciously or unconsciously, or voluntarily.

POLICIES

PRIVACY POLICY TO PROTECT THE INFORMATION CONTAINED IN THE ACADEMIC RECORDS (FERPA LAW)

The University complies with the provisions of the Buckley Amendment (*Family Educational Rights and Privacy Act of 1974, as amended*). This federal law protects the privacy of student educational records and establishes their right to inspect and review those records. This provides further guidelines for correcting the accuracy of the information through informal and formal hearings. Students have the right to file complaints if they so wish to “*The Family Educational Rights and Privacy Act Office, Department of Health, Education and Welfare, 330 Independence Avenue, S.W. Washington, D.C. 20201*”, in relation to alleged breaches of the Act by the University.

The University, through Student Identification, allows students to access their information that the University handles. In the case of an amendment, the student will request the change through the PANAL.

PROCEDURES AND MEASURES TO LIMIT ACCESS TO STUDENT ACADEMIC RECORDS

Student documents are safeguarded in a computing system.

Student documentation is also physically preserved and stored in special units by the Dean of Students Affairs. This executive has an access key to these units which are accessible with digital lock

and electronic key. The password is changed every six (6) months by the Dean of Administration and Finance.

The physical space of the computing facilities and the physical documentation are kept in a fireproof area and within safe temperatures to preserve physical and digital documents.

PROTECTION MEASURES AND CONFIDENTIALITY OF CREDIT OR CREDIT

The Registrar's Office is responsible for the custody and maintaining all official Academic Records or Credit Transcripts of the student, as well as their delivery and certifying that the student has satisfied the requirements for graduation.

The data related to the student record, such as the enrollment data, subjects passed, withdrawals, and credit transcripts are maintained in the database, as of the student's admission to the Institution until they are awarded the degree.

The Registrar's Office records all of the student's academic elements, such as tuition, approved courses, withdrawals, their academic program, credit transcripts, honors, academic progress, among others. The Registrar's Office digitalizes each academic record so as to preserve all of the student's information.

PROCEDURES AND MEASURES TO PROTECT ACADEMIC RECORDS FROM FIRE, FLOOD AND OTHER DISASTERS

The academic and digital "Backup" records are saved in the anti-flooding, fireproof and anti-shock cabinets.

POLICY ON UNAUTHORIZED SERVER ACCESS

University servers are considered assets and their security is therefore quite comprehensive including the control of access, hardware and software manipulation, and monitoring the activities of the staff assigned to managing their tasks, use and/or maintenance.

University servers are located in restricted-access sites, and the access to its premises is only allowed by the Technologies Director. This executive has an access key to these units which are accessible with digital lock and electronic key. The password is changed every six (6) months by the Dean of Administration and Finance.

If a student accesses the servers without authorization, this will be regarded as a serious offense and the action taken may lead to expulsion and / or a lawsuit by the University against the student.

If a person outside the University accesses the servers without authorization, the University may sue them.

Any member of the University community, employee, customer or user who, without authorization, accesses, uses, destroys, alters, dismantles or unconfigures the information technologies of the University, its properties or third persons, threatens access and information and jeopardizes the

security to create intellectual products, resulting in damage to the institutional order. Such behavior will be punished with a disciplinary action in accordance with University regulations, as well as other actions of the law.

The University catalogs as unacceptable, unethical and cause for disciplinary action up to and including the non-reallocation, expulsion, dismissal, or any other legal action, any activity that violates the copyright or patent protection and authorizations, as well as agreements and other contracts registered at the University or of third parties. The Institution will punish any person who interferes with the use for which information resources are directed at, attempts to get or obtain unauthorized access to these resources, or who, without authorization destroys, alters, dismantles, unconfigures, or impedes the right to access or otherwise interferes with the integrity of computerized information or the information resources.

Reading this institutional policy is compulsory for the users of the information system at the time of being granted access to the same. The implementation of this policy will be in charge of each academic unit or administrative direction in coordination with the Dean of Administration and Finance.

USE AND DIVULGENCE OF THE SOCIAL SECURITY NUMBER

UNIB completely complies with the laws that protect the privacy of the social security number, and any employee who reveals this number, of other employees, students or any person that has any contractual relation with the institution, will be subject to immediate dismissal and the institution can take legal action against the employee. In UNIB we comply with Act Num. 186 of September 1, 2006, that prohibits the use of the Social Security Number as routine identification in public and private educational institutions from primary level to graduate level, under penalty of receiving administrative penalties by the Puerto Rico Council of Education (CEPR).

In compliance with Act Num. 111 of September 7, 2005, “Citizen Information on Data Banks Security Act”, if there is a violation in security and non-authorized access to the documents that contain the social security number, the person affected will be notified immediately through mail, e-mail or public service so that they can obtain more information. The Department of Consumer Affairs (DACO in Spanish) will also be notified in a period not longer than 10 days.

In accordance with Act Num. 207 of September 27, 2006, an Act that forbids all employers of private companies and public corporation to use the Social Security Number of the employees as identification mean, UNIB does not use the Social Security Number to identify its employees, nor the students

PLAN TO FACILITATE ACCESS FOR STUDENTS WITH DISABILITIES TO THE FACILITY AND INSTITUTIONAL ACTIVITIES (ADA LAW)

Although the University will offer all its courses as distance learning, the physical facilities have the minimum requirements necessary to facilitate access for students with disabilities. In addition, deaf students may use the services of an *American Sign Language* translator through www.globalvrs.com, where they can receive services in Spanish or English This fulfills the norms of the *American Disability Act.*, of July 26, 1990 and then amended with changes and put into effect on January 1, 2009.

Students with special needs may address the Dean of Student Affairs, who will refer the case to the Professional Counselor as necessary.

RIGHTS OF MILITARY STUDENTS

UNIB complies with Act Num. 109 of April 11, 2003, which regulates the contractual relations between the military students of post-secondary education in the Commonwealth of Puerto Rico and higher education institutions. We recognize and respect the basic civil rights recognized in this law.

Any student that has been enabled by the United States Armed Forces or the National Guard of Puerto Rico shall notify and submit evidence to UNIB of their activation and will be immediately granted a deferment until the student informs that the activation has ended. UNIB will notify the professors of the active classes at the time and they will be put in hold until the student comes back. To the extent possible, UNIB will attempt to ensure that the same professor offers the course to the student, but if not possible, we will take the necessary measures to ensure that the student is affected as least as possible.

POLICY FOR MAINTAINING THE ACADEMIC OFFERING AND GUARANTEE OF STUDIES CONTINUITY IN THE CASE OF INSTITUTIONAL CLOSURE (TEACH-OUT)

Policy on Maintaining an Academic Offering

The University ensures that all offered programs have been the result from the studies on the social needs and scientific-professional requirements, by which the studies offer is pertinent and proper, and will be kept while those needs and/or requirements exist, which are expected to be no less than five years so as to generate a large number of graduates that may apply their knowledge.

The University guarantees the following to all its students:

- solve each incidence as is possible;
- update its content every two years or at any time when required;
- update (if required) the studies programming sequence every year;
- update (if required) the studies program; and,
- update the methodologies at its discretion according to the students' level of success.

All change will not affect active students at the time of the changes and shall be regulated by the rules of their academic life, maintaining their studies program for two years.

Guarantee of continuity of studies in case of institutional closure

In the event of closure, the University commits itself to the completion of all of its active students' studies under the terms of their contracts (Student Agreement).

The University:

- Will keep an office to address students for a lapse of one year.
- Will keep a list of active students by program , which will have the following information: name, ID, (passport number or driver’s license), Login, estimated date of completion, and the students’ academic and financial status.
- Will continue to offer the programs through the Virtual Campus until the student completes their studies, without any additional cost.
- The cancellation and reimbursement policies in the Enrollment Agreement will apply in case the student decides not to continue with their studies.
- Following the standards established in Article 48, Regulations for the Licensing of Higher Education Institutions in Puerto Rico of October 9, 2012, the Board of Postsecondary Institutions (JIP).
 - Will request the JIP to take custody of the academic records from active and graduate students, through the deliver of their digital copy since the beginning of operations.
 - Will notify active and graduate students and the JIP about these measures through digital and physical means.

POLICY ON BULLYING AND CYBERBULLYING

A. Objective

In compliance with Act 104 of 2016, “Anti-Bullying/Harassment”, also known as the Alexander Law or Cyberbullying, UNIB has established the following methods of prevention and action against this practice. The Universidad Internacional Iberoamericana (UNIB) endorses the emerging legislative purposes for safeguarding the academic environmental as an emotional and physical violent free space.

B. Justification

This policy arises considering, as is interpreted in the law, that in order for students to learn and achieve outstanding academic standards, a safe environment free of violence is needed. Harassment, intimidation and bullying or cyberbullying are behaviors that interfere with the ability to learn in a country’s public education system and private sector.

C. Definition and description of harassment and school and cyberbullying

The law defines the following types of harassment and intimidation:

- Harassment and intimidation and/or bullying; any pattern of intentional actions, whether through psychological, physical, cybernetic, or social abuse, that has the effect of frightening a student or a group of students and interferes with the student’s academic opportunities, and performance, both in the classroom and in the student’s immediate social environment. Harassment and

intimidation and/or bullying must be an harassment pattern, consisting of more than one act, and usually extending over weeks, months and even years.

- “Harassment and intimidation by any electronic means or through the use of Internet and/or cyberbullying”; is the use of any oral, written, visual, or textual electronic communication, made for the purpose of harassing, annoying, intimidating, and afflicting a student, or a group of students; and which often results in damage to the physical, mental, or emotional integrity of the affected student, and/or to the student’s property, and unwanted interference with the affected student’s opportunities, performance, and benefit. Even if the actions do not originate in the school or the immediate academic environment, cyberbullying has serious repercussions and adverse consequences on the educational environment.

D. Expectations and Institutional Policy

UNIB aims to offer high quality programs to all its students. We strongly believe that our students deserve a safe, friendly and respectful environment. The University promotes a positive culture of zero tolerance toward school harassment, such as bullying and cyberbullying, in such a way that the entire university community has the right of being respected, to learn and teach, and the right to feel safe with their surroundings. The purpose of this policy is to prevent bullying and to provide guidance on the policies established in this regard. To achieve this, the University seeks to create a culture that:

- Enables the student to thrive free from discrimination and any form of harassment.
- Does not tolerate, condone, or lessens harassment behavior.
- Is aware of what constitutes harassment behavior.
- Provides support to harassment victims.
- Firmly handles harassment situations.

E. Responsibilities of the University Community members

The Rectory is responsible for:

- Annually provide written versions of this policy and its processes to students and the entire university community.
- Inform all staff about the bullying or cyberbullying policy.
- To publish and disseminate this policy and process throughout the university community through the website, catalogs and institutional manuals.
- To monitor the implementation and execution of this policy and its processes.
- Maintain statistics on those sexual harassment and intimidation cases of the University and deliver them to Board of Postsecondary Institutions (JIP) before the 1st of June of each year.

The Student Affairs Deanship is responsible for:

- Guide the student on the bullying or cyberbullying policy.
- Ensure the implementation of this policy considering the processes and consequences established here, and with this ensure:

- Prohibition and non-tolerance of any act of harassment, bullying or cyberbullying among members of the University Community.
- Any member of the University Community who commits an act(s) of bullying or cyberbullying will have limited or restricted access to the physical and digital facilities of the University until determined otherwise.
- That any case of bullying or cyberbullying will be addressed within 72 hours of receiving the complaint.

The Faculty and all university staff are responsible for:

- Immediately report any bullying or cyberbullying incidents they are notified about to the Dean of Student Affairs.

The Professional Counselor is responsible for:

- Maintaining written documentation of the complaint of harassment behavior.
- Notify both parties that an investigation of the complaint received will be initiated.
- Notify the Rector and the Disciplinary Committee, if necessary, of the results of the investigation once it is completed.
- Notify both parties of the results of the investigation and the case resolution and the disciplinary measures, if applicable.

F. Prevention Strategies

- The University will publish the bullying policy throughout the academic year to guide the entire university community on the subject and how to handle situations that arise in the educational setting.
- This policy includes the definition of bullying; how to prevent it and how to act if you observe or are subjected to bullying. It also establishes intervention procedures; who to turn to and the applicable disciplinary measures.
- The University opens the way for those recommended activities that reinforce and prevent risk situations. If feasible, the University will coordinate campaigns with external agencies or entities.
- It will provide the following recommendations to students:
 - Never disclose your password or access codes.
 - Do not disclose your information or details of your private life to strangers.
 - Remember that the use of networks for illegal activities, such as fraud, scams and pornography, among others, is very common.

If you consider yourself a victim of bullying or cyberbullying:

 - * Keep the evidence either in a file, take photos or screenshots and immediately report the situation to your Professor, Program Director, Department Director or Student Affairs.
 - * Do not respond to the harassment.

G. Procedure for disclosure of the protocol

The bullying and cyberbullying policy will be disseminated throughout the year through the website, the Institutional Catalog and the Student Manual.

H. Procedure for case documentation, confidentiality and record keeping

Case Documentation

The harassment must be reported in writing to the Dean of Student Affairs. The case will be analyzed by the Dean of Student Affairs, who, if deemed necessary, will refer it to the Professional Counselor for handling.

The student should offer details about the harassment in the written report. In cases of cyberbullying, the student must be able to evidence it by means of fixed views, photos or any other format.

The case will be documented following the case reporting procedure set out in point I: ***Case Complaint Procedure***, in this policy.

Record Confidentiality and Handling

The documentation for students that are victims of bullying or cyberbullying will be saved in a digital system and physically conserved inside special safekeeping units of the Student Affairs Deanship. This executive has an access key to these units which are accessible with digital lock and electronic key. The password is changed every six (6) months by the Dean of Administration and Finance. Only the Professional Counselor will have access to these records and the information contained therein. Those complaints that the Dean of Student Affairs, after careful evaluation, does not consider to be bullying or cyberbullying will be filed in the student's record.

I. Case Complaint Procedure

It will be the student's prerogative to file a complaint with the Puerto Rico Police, if they believe that the law has been violated.

Officials in charge of handling the complaint or event

- Dean of Student Affairs.
- Professional Counselor.
- Disciplinary Committee.

Form

When a message about alleged bullying or cyberbullying behavior is received in the Students Affairs email, the ***Complaint and Claims Form*** is sent to the student. Once the completed and signed form is received, the Student Affairs officer sends it to the Dean of Student Affairs who will evaluate the case and, if necessary, refer the complaint or claim to the Professional Counselor.

Details of the investigation will be compiled in the ***Narrative Record Form***.

J. Complaint Investigation Strategies

The University will handle complaints or grievances related to cases of Bullying or Cyberbullying as follows:

- The student fills out the Complaint or Grievance form and the Dean of Student Affairs refers it to the Professional Counselor.
- The Professional Counselor will interview the parties involved and evaluate the evidence presented under the necessary confidentiality.
- The Professional Counselor has 15 days to conduct the investigation with the parties involved.
- In the event that the student has filed a complaint with any state authority, the University will be subject to the determination of the Court or the authority concerned. In the meantime, the parties will undergo a process of orientation.
- The Professional Counselor will make a preliminary written and detailed report on the situation, which will be presented to the Dean of Student Affairs.
- In the event that a misdemeanor or a violation of policy has been verified, the case will be referred to the Rector and the Disciplinary Committee.
- The disciplinary measure(s) will be applied according to the offense committed.
- The file will be preserved indefinitely.
- The Professional Counselor will notify the concerned UNIB staff (Rector, Faculty) of the participation of the student(s) in a situation being addressed if the situation affects the ordinary development of the student(s) in the daily academic year.

K. Intervention strategies and sanction for cases

Intervention strategies

- Interviews with the victim and the perpetrator.
- Professional counseling with both parties.
- Resolving any possible bullying or cyberbullying incidents, which may include referring the victim and/or the bully to any other service that they feel is appropriate.

Infractions

- **Less Serious**
 - Altering the normal development of any academic activity through the Virtual Campus and/or during university visits.
- **Serious**
 - Write inappropriate or disrespectful expressions toward members of the University Committee through the Virtual Campus.
 - Distribute material through the Virtual Campus that may be offensive to the recipient.
 - Written expressions through the Virtual campus that damage the student's image.

- File maliciously false information to the Disciplinary Commission.
- Relapse of a less serious offense.
- **Very Serious**
 - Perpetrate acts of violence, verbal or written against the student, for example, threats, slander, defamation or interference in the exercise of their rights.
 - Relapse of a serious offense.
 - Fail to appear on the date and time indicated by a subpoena from the Disciplinary Commission. Such appearance can be physical or through electronic means to validate the student's identity.
 - The Disciplinary Commission may extend or alter this list, without excluding or removing any infringement according to the cases being investigated and prosecuted.

Possible Sanctions

- The Professional Counselor will recommend the need to activate the Disciplinary Committee to the Rector.
- This committee will evaluate the case and apply the disciplinary actions, which may include, but are not limited to:
 - Verbal warning.
 - Written warning.
 - Temporary suspension from the Virtual Campus and participation in all university activities.
 - Prohibition of entry into the University's physical facilities for the sanctioned period.
 - Expulsion from the University, which means an indefinite admission prohibition of the same ("permanently withdrawn" student).

The sanctions will be recorded in the file prepared and kept by the Professional Counselor. The imposition of disciplinary measures outlined above will be in accordance to the mitigating circumstances or aggravating responsibility in each case. Good academic background, prior good conduct, or remedying part or all of the damage done by the infraction can be considered as extenuating circumstances.

The Disciplinary Committee may, in certain cases, lower the sanction degree in exchange of alternative sanctions which promote the rehabilitation of the student and the benefit of the University community.

Disciplinary measures will be applied without affecting the exercise of appropriate legal actions according to the law in force in the country. By being a Distance Education University, legal action outside the country or application of international standards are not excluded.

Students will be notified of their right to appeal the Rector's and the Disciplinary Committee's decision regarding the disciplinary actions, as contained in this policy. The student will have the right to appeal within 10 days.

L. Follow-Up Strategies

The Professional Counselor will determine the need for professional assistance for both parties based on the results of the investigation. If intervention by a mental health professional is deemed necessary, the Professional Counselor will proceed to make the referrals to the corresponding agency, described in the section ***Referral Guidelines for Health Professionals***. Follow-up and treatment will be part of the Action Plan. The Action Plan's main objective is to establish actions that contemplate socio-educational training and guarantee the safety of those involved. It must also consider actions that contribute to the integral development and continuity of the educational goals of the students.

The Professional Counselor will complete the research report with the details and evidences that delimit the damage caused, if any, and will establish the Action Plan for both parties. Sanctions against the offender will be imposed by the Disciplinary Committee.

The University has the responsibility to:

- Implement actions to stop bullying and/or cyberbullying incidents.
- Watch for the repetition of such incidents and act diligently if they do happen again.
- Seek support from other institutions and agencies when necessary.
- Ensure the immediate safety and protection of the integrity of the affected student, without blaming or stigmatizing the alleged harasser.
- Safeguard the confidentiality of each person involved.

The mechanisms for protection and confidentiality when handling the information and the file will be carried out in accordance with the provisions of the section on ***Record Confidentiality and Handling***. The complaint files for bullying and cyberbullying will be available to law enforcement authorities and the Puerto Rico Board of Education upon written request.

M. Referral guidelines for health professionals

If students in Puerto Rico require the assistance of a professional, they will be referred to:

- Women's Procurator's Office - (787) 722-2977.
- Mental Health and Addiction Services Administration (AMSCA, Spanish Acronym) (787) 763-7575.
- Association of Psychological Services (787) 764-7594.
- Professional/private hospitals.

International students will be referred by the International Student Affairs department to those health professionals available in their country. These students will follow the process set forth in this policy, and once the Professional Counselor determines the need for assistance by a mental health professional, will contact the Dean of Student Affairs and the International Student Affairs department for due process.

ABOUT THE ETHICAL AND LEGAL USE OF INFORMATION TECHNOLOGIES

The institutional policy ensures the appropriate use of information technology and telecommunications for the university's community, the University officers, external clients and users of information systems and telecommunications of the University. The policy applies to the institutional use of the University's information on paper, tape, electronic communication and other analog media.

The University will provide access to local sources of information, nationally and internationally, to ensure intimacy and confidentiality in the use of information technologies, including email files and printed lists of users. Also, it will protect administrative, educational and research information systems, from accidental modifications or unauthorized and intentional misuse, destruction, or disclosure

Also, it will strive to safeguard the integrity of the information systems in workstations, networks, laboratories and other University facilities or properties.

All users have the responsibility to use information technology efficiently and effectively, with deference to the trust and public ethics, in accordance with the laws and University regulations. They must also commit to cooperate with state and federal agencies, as well as other interested parties, so that the environment of information technology at the University and its internal and external networks remain protected from any interference.

FACULTY

RECORD OF DEPARTMENT DIRECTORS

Academic Departments	Academic	Grade Academic	Institution	Associated Programs
Department of Environment and Sustainability	Dr. Eduardo García	Technical-Superior Industrial Engineering with specialization in Energetic Techniques.	Higher Technical School of Industrial Engineers. Polytechnic University of Catalonia. Spain 1996.	<ul style="list-style-type: none"> Master in Environmental Management and Auditing (MAMGA).
		Master in Environmental Technology and Engineering.	Polytechnic University of Catalonia. Spain 2006.	
		Doctor in Engineering Projects: Environment, Quality, Safety and Communication	Polytechnic University of Catalonia. Spain 2011.	
Department of Innovation, Business and New Technologies	Manuel Masías Vergara	Industrial and Systems Engineering	University of Piura, Peru (2001)	<ul style="list-style-type: none"> Master in Strategic Management with a Specialty in Management (MDE). Master in Strategic Management with a Specialty in Telecommunications (MDETEL). Master in Strategic Management with a Specialty in Information Technology (MDETI).
		Master's Degree in Strategic Management in Information Technology and Telecommunications	University of Leon, Spain (2009)	
		Doctor in Engineering Projects	Universidad Internacional Iberoamericana (2018)	
Department of Language and Communication Science.	Dr. Silvia Pueyo	Doctorate in Education Sciences	University of Barcelona	<ul style="list-style-type: none"> Master in Teaching Spanish as a Foreign Language (FPMELE). Master in Teaching English as a Foreign Language (FPMTFL).
		Master in Linguistics Applied to the Teaching of Spanish as a Foreign Language	University of Jaen and the Universidad Internacional Iberoamericana (2008-2009).	
Department of Health Sciences	Dr. Irma Domínguez	Doctorate in Education	Universidad Internacional Iberoamericana (2021)	<ul style="list-style-type: none"> Master in Physical Activity: Sports Training and Management (SNMAFEGD).
		Master in Physical Activity. Sports and Management	Universidad Internacional Iberoamericana (2012)	
		Master in Vegetarian Nutrition with a Specialty in Dietetics	University of Santiago de Compostela (2007)	
		Degree in Human Nutrition and Dietetics	University of Navarra (2000)	
Department of Projects	Dr. Roberto Álvarez	Architecture	University of Buenos Aires - Argentina	<ul style="list-style-type: none"> Master in Project Design, Administration and Management (MDGDP). Master in Project Design, Administration and Management with a Specialty in Architecture and Urban Planning (MPAU). Master in Project Design, Administration and Management with a Specialty in Innovation and Product (MDPIP).
		Graduate in Strategic Planning	University of Buenos Aires - Argentina	
		Graduate in Investment Project Appraisal for Non-Specialists	University of Buenos Aires - Argentina	
		Specialist in Strategic Management for Design. Project and Design Management	University of Buenos Aires - Argentina - Polytechnic University of Milan	
		Doctor in Engineering Projects	Polytechnic University of Catalonia	

RECORD OF FACULTY MEMBERS

MAIN PROFESSORS					
Professor	CV Summary	Doctorate	Program	Courses Taught	
Dr. Abel Nogueira López	<ul style="list-style-type: none"> Bachelor's Degree in Psychology from the University of Santiago de Compostela (2010). Research in Sciences of Physical Activity and Sport at the University of Leon (2015). Master's Degree in Psychology of Physical Activity and Sport by UNED (2013). Member of the Spanish Federation of Psychology and Sport (FEPD) 	<ul style="list-style-type: none"> Doctor in Sciences of Physical Activity and of Health at the University of Leon (2019) 	<ul style="list-style-type: none"> Master in Physical Activity: Sports Training and Management. 	<ul style="list-style-type: none"> SN050 - Sport Psychology. SN156 - Psychosocial Aspects of Physical Activity for Health Master's Thesis 	
				Academic Load	3
				Number of Subjects	3
Dr. Abel Quiñones	<ul style="list-style-type: none"> Degree in Business, Central University of Marta Abreu de Las Villas, Cuba (1999). Degree in Education, Specialty in Mathematics, Instituto Superior Pedagógico Félix Varela, Cuba (1979). Academic Director of the Universidad Privada del Sur de México, Mexico (2013-2017). Academic Vice-Rector of the University of Cienfuegos, Cuba (1993-2005). Director of the Department of Basic Mathematics of the Higher Technical Institute of Cienfuegos, Cuba (1987-1990). Vice-Dean of the Faculty of Mechanical Engineering of the Higher Technical Institute of Cienfuegos, Cuba (1986-1987). Director of the Department of Mathematical Analysis, Universidad Pedagógica Félix Varela, Cuba (1980-1982). 	<ul style="list-style-type: none"> Doctor in Educational Sciences, University of Oviedo, Spain (2003). 	<ul style="list-style-type: none"> Master in Education Doctorate in Education with a Specialty in Research 	<ul style="list-style-type: none"> FP119 - Learning Factors DO008 - Thesis Proposal DO009 - Thesis Development DO010 - Thesis Dissertation Master's Thesis 	
				Academic Load	5
				Number of Subjects	3
Dr. Adriana Mayorga	<ul style="list-style-type: none"> 2010. Master's Degree in Human Resources and Knowledge Management, University of León (Spain). 2004. Bachelor's degree in Psychology from the Santo Tomás University (Colombia). <p>Professional Experience:</p> <ul style="list-style-type: none"> Psychologist with expertise in the diagnosis, analysis, intervention planning and evaluation of human behavior forms. Practitioner psychologist at the Psychology Clinic, Santo Tomás University, <i>Opción Vida Justicia y Paz Corporation</i>, June - December 2001. Community psychologist in the Municipality of Madrid-Colombia, May-December 2002. Researcher, Book Marketing, January 2004-December 2004. Lecturer at Sonría Polytechnic Foundation, January - April 2005. Head of Human Resources at Lubri Holanda Amsteloil Cia Ltda, January-September 2005. Executive Director of Industrial Technology Innovation Center of Colombia (CITIC, Spanish acronym) 2010. 	<ul style="list-style-type: none"> Doctor in Project Engineering: Environment, Quality, Safety and Communication in Polytechnic University of Catalonia (2015) 	<ul style="list-style-type: none"> Master in Strategic Management with a Specialty in Management Master in Strategic Management with a Specialty in Telecommunications Master in Strategic Management with a Specialty in Information Technology Master in Project Design, Administration and Management Master in Physical Activity: Sports Training and Management 	<ul style="list-style-type: none"> DD030 - Position Analysis, Description and Value DD033 - Compensations and Incentives DD046 - Personal Marketing DD048 - Quality as a Management Tool for Human Resources DD111 - Professionalization of Family Business DD1021 - Strategic Management of Human Resources TI018 - Innovation, Culture and Work Management in the Communication Society 	
				Academic Load	7
				Number of Subjects	7
Dr. Águeda Moreno Morenos	<ul style="list-style-type: none"> Degree in Philosophy and Arts - Philology section (1997) from the University of Granada; Doctorate in Philology (2003) from the University of Jaén; Master's Degree in Dictionary Development and Quality Control of the Spanish Lexicon (2010) from the UNED; Lecturer at the University of Jaén (2011). Full-time teaching experience performed within the Department of Spanish Philology, Spanish Language Area of the University of Jaén (from 2001- present) in the Degree of Hispanic Philology, Degree in Early Childhood Education, Diploma in Teaching Spanish as a Foreign Language; Master's Degree in Spanish Music Education and Bachelor of Arts in English Philology. Two research paths of the CNEAI. 	<ul style="list-style-type: none"> Doctor in Hispanic Philology, University of Jaén. (2003) 	<ul style="list-style-type: none"> Doctorate in Education with a Specialty in Research 	<ul style="list-style-type: none"> DO008 - Thesis Proposal DO009 - Thesis Development DO010 - Thesis Dissertation 	
				Academic Load	3
				Number of Subjects	1

MAIN PROFESSORS					
Professor	CV Summary	Doctorate	Program	Courses Taught	
Dr. Agustín Locón	<ul style="list-style-type: none"> • Master's degree in Social Sciences, Bachelor's degree in History. • Postgraduate studies professor at the Mariano Gálvez University and the Panamerican University, both in Guatemala. • Member of the Pan American History Commission of the Pan American Institute of Geography and History. • Author of several publications among which stand out: Guatemala: Education and Development. Las Maras, violent minorities in Central America. Ancestral feelings and formation of the imaginary national subject in Guatemala. 	<ul style="list-style-type: none"> • Doctorate in Social Sciences. Latin American Faculty of Social Sciences. Academic Headquarters Guatemala. (2009) 	<ul style="list-style-type: none"> • Doctorate in Education with a Specialty in Research 	<ul style="list-style-type: none"> • DO008 - Thesis Proposal • DO009 - Thesis Development • DO010 - Thesis Dissertation 	
				Academic Load	3
				Number of Subjects	1
Dr. Alba Gutiérrez	<ul style="list-style-type: none"> • Master of Arts in Spanish, Florida State University, United States (2012). • Master's degree in Secondary and High School, Baccalaureate and Professional Training and Language Education, National University of Distance Education, Spain (2013). • Bachelor's in English Philology, University of Deusto, Spain (2010). • Professor of the European University of the Atlantic, Spain (as of 2014). • Professor at the Universidad Nacional de Educación a Distancia, Spain (as of 2015). • Research Staff in the English and German Philology Department of the University of the Basque Country, Spain (2014). • Associate Professor in the Department of Philology at the University of Cantabria, Spain (2012-2014). • Assistant Professor in the Department of Modern Languages at Florida State University, USA (2010-2012). 	<ul style="list-style-type: none"> • Doctor in Second Language Acquisition in Multilingual Contexts, University of the Basque Country, Spain. (2018) 	<ul style="list-style-type: none"> • Master in Teaching Spanish as a Foreign Language • Master in Teaching English as a Foreign Language 	<ul style="list-style-type: none"> • FP038 - Spanish Grammar for SFL professors • FP037 - Content & language integrated learning • Master's Thesis 	
				Academic Load	3
				Number of Subjects	3
Dr. Alberto Vera	<ul style="list-style-type: none"> • Associates Degree in Advanced Studies, University of León, Spain (2010) • Urban and Regional Planner, Postgrad, Faculty of Architecture and Urban Planning, University of Buenos Aires (1994) • Adviser of the Inspectorate, Municipality of Río Grande, Providence Tierra del Fuego. Urban, Traffic and Transportation Planning, (2012) • General Coordinator, BID – UNPRE Ministry of National Economy, Sub- secretary of Urban and Housing Planning from the Providence of Buenos Aires (2009) • Head Professor, Strategic Planning and Social Programming, Masters in Social Policies from the Universidad de Buenos Aires (2010) • Academic Coordinator of Design, Master in Project Design, Management and Administration, Fundación Universitaria Iberoamericana, Universidad de León, Spain, Universidad Internacional Iberoamericana, Mexico (from 2005) • Head Professor and Researcher, Specialization in the Approach to Social Problems at the Community Level, Universidad Nacional de Lanús –Ministry of National Social Development (2006-2009) 	<ul style="list-style-type: none"> • Doctorates in Economics and National Integration and Development, University of Leon, Spain. (2016) 	<ul style="list-style-type: none"> • Master in Project Design, Administration and Management with a Specialty in Architecture and Urban Planning • Master in Project Design, Administration and Management with a Specialty in Innovation and Product • Doctorate in Projects with a Specialty in Research 	<ul style="list-style-type: none"> • AU003 - Technology Impact in Urban Architectural Projects: • AU014 - Theory of the Object • AU015 - Relationship between Innovation, Creativity, Productivity, and Competitiveness • DD235 - Introduction to the Project Design: from the Conflict to the Problem. • DD236 - Systems Design - Project Solutions • DD237 - Desired Service and Conditions for Provision • DD238 - System Solution: Functional Analysis in the Project • DD239 - Roles of People in the Project • DD240 - Project Security and Reliability • DD241 - Environmental Viability of the Project • DD242 - Project Proposal: Specifications • DD243 - Project Draft Preparation 	
				Academic Load	12
				Number of Subjects	4

MAIN PROFESSORS					
Professor	CV Summary	Doctorate	Program	Courses Taught	
Dr. Alejandro Alonso García	<ul style="list-style-type: none"> Post-doctorate at the Materials Unit of the Scientific Research Center in the Yucatan (2015-2016) Master of Science in Mechanical Engineering, Specialization in Energy (9.8/10) Mechanical Engineer with a Specialization in Mechanical Design from the Technological Institute of Merida 2005 Has 7 publications, 5 in JCR magazines, has taught at the Doctorate, Master's and Bachelor's levels in subjects related to the physical-mathematical areas. 	<ul style="list-style-type: none"> Doctor of Science in Mechanical Engineering, Specialty in the Field of Energy, School of Mechanical Engineering, Zacatenco National Polytechnic Institute Campus (honorable mention). (2015) 	<ul style="list-style-type: none"> Doctorate in Projects with a Specialty in Research 	<ul style="list-style-type: none"> DO008 - Thesis Proposal DO009 - Thesis Development DO010 - Thesis Dissertation 	
				Academic Load	3
				Number of Subjects	1
Dr. Alejandro Fuentes Penna	<ul style="list-style-type: none"> Engineer in Computational Systems, Technological Institute of Cuautla. Master's degree in Computational Sciences, Technical Institute of Higher Studies, Monterrey. Update courses: Diploma in Competency-based Education, Information Technology Project Management, Research Seminar with SPSS, ArcGIS 10.0, Digital Map of Mexico, Educational Technology, Java Developer 6.0 Course Research Professor in Higher Education Institutions. Teacher in postgraduate degree courses, on-line courses and blended program courses. Researcher in Scientific, Intelligent and Bioinspired Computing with indexed articles, JCR and conferences in different areas. Science, dissemination and teaching books published. Bachelor's Degree and Postgraduate Direction. Member of the State Researcher System 2011-2012. Counsel of Science and Technology of the State of Morelos. 	<ul style="list-style-type: none"> Doctor in Strategic Planning and Technology Management, Autonomous Popular University of Puebla (2012) 	<ul style="list-style-type: none"> Doctorate in Projects with a Specialty in Research 	<ul style="list-style-type: none"> DO008 - Thesis Proposal DO009 - Thesis Development DO010 - Thesis Dissertation 	
				Academic Load	3
				Number of Subjects	1
Dr. Alejandro Tapia	<ul style="list-style-type: none"> Doctorate in Information Technology and Telecommunications Sciences from the Complutense University of Madrid. Certified by ANECA as a Hired Professor Doctor and Professor of Private University. Professor at Miguel de Cervantes European University and at University Loyola Andalucía. He has carried out exchanges with Portuguese, Dutch and German universities. Six-year research period in the National Commission for the Evaluation of Research Activity (CNEAI) Member of the Ethics Committee of University Loyola Andalucía. Participation in different R&D projects for public and private entities in Spain. Author of didactic guides on advertising and public relations. Author of scientific articles for professional journals on advertising, neuroscience, information transparency, corporate communication. 	<ul style="list-style-type: none"> Doctor of Marketing from the Complutense University of Madrid (2005) 	<ul style="list-style-type: none"> Master in Strategic Management with a Specialty in Management Master in Strategic Management with a Specialty in Information Technology 	<ul style="list-style-type: none"> DD004 - Marketing DD160 - Market Research DD162 - Marketing Strategy Development DD164 - Relational Marketing DD170 - Marketing Services TI014 - Trade and E-marketing 	
				Academic Load	6
				Number of Subjects	6
Dr. Alfonso Jesús Cruz Lendínez	<ul style="list-style-type: none"> Advanced Professional Degree in Nursing, Hoogeschool Zeeland (Netherlands). Advanced Professional Degree in Workplace Hazard Prevention, University of Alcalá de Henares (Spain). Graduate in Nursing, University of Granada (Spain). 20 years of health care work experience in hospitals. 12 years of experience in university education. 5 years as the Dean of the Faculty of Health Sciences, University of Jaén. Current Vice-Rector of Faculty and Academic Administration. President of the AGEING LAB Foundation, focused on quality of life in aging. Member of several health management, geriatrics and gerontology associations 	<ul style="list-style-type: none"> Doctor in Nursing and Citizen Culture, University of Jaén (Spain). (2007) 	<ul style="list-style-type: none"> Doctorate in Education with a Specialty in Research 	<ul style="list-style-type: none"> DO008 - Thesis Proposal DO009 - Thesis Development DO010 - Thesis Dissertation 	
				Academic Load	3
				Number of Subjects	1

MAIN PROFESSORS					
Professor	CV Summary	Doctorate	Program	Courses Taught	
Dr. Alina Celi	<ul style="list-style-type: none"> Master in Economic Administrative Law by the University of Montevideo (Uruguay). Postgraduate in Environmental Law by the Faculty of Law from the University of Austral of Buenos Aires (Argentina) Bachelor's in Law by the University of La República Oriental del Uruguay. 	<ul style="list-style-type: none"> Dr. in Environmental Law by the University of Alicante (Spain). Dr. in Law and Social Sciences by the University of La República Oriental del Uruguay (UDELAR). (2011) 	<ul style="list-style-type: none"> Master in Environmental Management and Auditing Master in Strategic Management with a Specialty in Management 	<ul style="list-style-type: none"> MA014 - Environmental Law Master's Thesis 	
				Academic Load	2
				Number of Subjects	2
Dr. Alina Pascual	<ul style="list-style-type: none"> Bachelor by the Faculty of Chemical Biological Sciences, Autonomous University of Campeche. Specialty: Pharmaceutical-Biological Chemistry (1992-1997) Masters Degree in Marine Sciences with a Specialty in Marine Biology. Center for Research and Advanced Studies of IPN (CINVESTAV); Merida Unit. (2000-2002) Diploma of Advanced Studies in the Area of Environmental Technologies, Polytechnic University of Catalonia. Barcelona, Spain (2005-2006). Full-time professor imparting the subjects of Ecology I, II, Research Methods and Documentary Research. Incorporated Private High School Luz Fidel Farías Avilés. Campeche, Mexico. (January 2009 - present) Academic Coordinator of the Competencies Program for middle, basic and higher levels. High School and Incorporated Preparatory School Luz Fidel Farías Avilés. Campeche, Mexico. (January 2009 -present) Doctorate Professor in Projects for the Universidad Internacional Iberoamericana (UNINI). (01 June (2014 to date) Complementary training: <ul style="list-style-type: none"> Teacher Training Course- FUNIBER (2015) Course "Training for Directors of Thesis" - FUNIBER (2015) 	<ul style="list-style-type: none"> Degree in Science of the Sea. Polytechnic University of Catalonia (UPC), Barcelona, Spain (2013) 	<ul style="list-style-type: none"> Master in Strategic Management with a Specialty in Management Master in Environmental Management and Auditing 	<ul style="list-style-type: none"> MA004 - Waste Management MA006- Climatology and Environment MA013 - Economy and the Environment MA081 - Urban Solid Waste MA082 - Industrial Waste MA083 - Rural Waste MA084 - Sanitary Waste MA093 – Engineering Recovery and Treatment of Waste MA014 - Recovery of Contaminated Soil MA249 - Analysis of Product Lifecycle and Carbon Footprint IP054 - Treatment of Contaminated Soils IP051 - Water Management: Basic Principles Master's Thesis 	
				Academic Load	13
				Number of Subjects	13
Dr. Álvaro Pérez García	<ul style="list-style-type: none"> Graduate in Advanced Third Cycle Studies, University of Granada. Degree in Pedagogy from the University of Malaga. Author of the book "Educational Institutions Facing Knowledge Society's Technological and Solidary Challenges". Author of several journal articles, oriented to didactic resources (movies, video games) as means of learning. Participation in the coordination of several educational events. Has been the Coordinator of Educational Projects of the Menéndez Pelayo International University, Línea de la Concepción headquarters. Since 2002, active communicator in lectures related to pedagogy and labor insertion for different social groups, presented in university national and international events. Has participated in different research projects related to visual communication in the academic sector, education for peace, multicultural dialog promotion and adult education. Teaching experience in different subjects in the Teaching Community College - SAFA, associated to the university of Jaén 	<ul style="list-style-type: none"> Doctor of Pedagogy from the University of Granada.. (2005) 	<ul style="list-style-type: none"> Doctorate in Education with a Specialty in Research 	<ul style="list-style-type: none"> DO008 - Thesis Proposal DO009 - Thesis Development DO010 - Thesis Dissertation 	
				Academic Load	3
				Number of Subjects	1

MAIN PROFESSORS					
Professor	CV Summary	Doctorate	Program	Courses Taught	
Dr. Álvaro Velarde Sotres	<ul style="list-style-type: none"> • Degree in Physical Activity and Sports Sciences, (USal, Spain) • Master's in Teacher Training for Compulsory Secondary Education (USal, Spain) • Master's Degree in Injury Prevention and Physical Rehabilitation (UCLM, Spain) 	<ul style="list-style-type: none"> • Doctor in Health Projects by the Universidad Internacional Iberoamericana of Puerto Rico (2019) 	<ul style="list-style-type: none"> • Master in Physical Activity: Sports Training and Management 	<ul style="list-style-type: none"> • SN048 - Training Theory and Practice • SN049 - Sports Planning • Master's Thesis 	
				Academic Load	3
				Number of Subjects	3
Dr. Amélia Stein	<ul style="list-style-type: none"> • Bachelor's in Physical Education from the Lutheran University of Brazil (ULBRA), Brazil. • Master in Physical Activity: Training and Sports Management (University of Leon, Spain) • Postgraduate subjects on: physical activity at school, physical condition assessment, the biomechanics of human movement, etc. • Experience as a physical evaluator, implementation and design of physical activity programs with elderly people. 	<ul style="list-style-type: none"> • Doctor in Physical Activity and Sports Sciences, University of Leon (Spain). (2016) 	<ul style="list-style-type: none"> • Master in Physical Activity: Sports Training and Management 	<ul style="list-style-type: none"> • SN115 - Contextualization of Physical Activity and Exercise in the Health Framework • SN159 - Physical Activity in Children and Teenagers • SN157 - Control and Prescription of the Physical Activity • SN158 - Physical Activity for Health in Different Diseases • SN160 - Physical Activity in Seniors • FP092 - Methodology of Scientific Research • Master's Thesis 	
				Academic Load	7
				Number of Subjects	7
Dr. Ana Rodríguez Zubiaurre	<ul style="list-style-type: none"> • Diploma of Advanced Studies Applications to the Finance and Insurance Sector, Economy, Environment, Infrastructure and Transport by the University of Las Palmas de Gran Canaria (Spain) • Degree in Science of the Sea. Specialization in Coastline Management from the University of Las Palmas de Gran Canaria (Spain). 	<ul style="list-style-type: none"> • Dr. in Applied Economics from the University of Las Palmas de Gran Canaria (2013) 	<ul style="list-style-type: none"> • Master in Strategic Management with a Specialty in Management • Master in Environmental Management and Auditing • Doctorate in Education with a Specialty in Research 	<ul style="list-style-type: none"> • TR043 - Tourism Foundations • TR008 - The Territory as a Tourism Resource • D0006 - Research Work I. • D0007 - Research Work II. • D0008 - Thesis Proposal • D0009 - Thesis Development • D0010 - Thesis Dissertation 	
				Academic Load	7
				Number of Subjects	5
Dr. Alexander Armando Cordovés Santiesteban	<ul style="list-style-type: none"> • Master in Educational Psychology, University of Havana, Cuba (2008-2010). • Diploma in University Teaching, University of Holguin, Cuba (2008) • Degree in Psychology, Central University of Marta Abreu de Las Villas, Cuba (1993-1998) • Course in Educational Psychology and Theories of Learning • Course in Innovation and Educational Quality: School Management • Collaborating researcher at the Federal University of Santa Catarina, Brazil. • Clinical Psychologist at with the Polyclinic Community • Participation in research projects and member of education research groups. 	<ul style="list-style-type: none"> • Doctorate in Social Anthropology, Federal University of Santa Catarina, Brazil (2017) 	<ul style="list-style-type: none"> • Master in Education • Doctorate in Education with a Specialty in Research • Doctorate in Projects with a Specialty in Research 	<ul style="list-style-type: none"> • D0005 - Methodology of Scientific Research (Part I). • FP084 – Environmental Education in Formal Education • FP112- Design and Evaluation of Training Proposals Based on ICT • FP123 - Educational Counseling and Mentoring • FP126 - ICT in Education and Learning Theories • Master's Thesis 	
				Academic Load	6
				Number of Subjects	6

MAIN PROFESSORS					
Professor	CV Summary	Doctorate	Program	Courses Taught	
Dr. Alice Sacheska Martinez Rappa	<ul style="list-style-type: none"> Master's Degree in Guidance and Counseling, Inter-American University of Puerto Rico, Arecibo Campus (2005-2007) Bachelor's in Elementary Education (kindergarten to sixth grade), University of Puerto Rico, Arecibo Campus (2002 - 2005). 15 credits approved in Administration and Supervision, Caribbean University, Vega Baja (2011) 	<ul style="list-style-type: none"> Doctor in Education with a specialization in Counseling. University of Puerto Rico, Metropolitan Campus (2014). 	<ul style="list-style-type: none"> Doctorate in Education with a Specialty in Research 	<ul style="list-style-type: none"> DO008 - Thesis Proposal D0009 - Thesis Development DO010 - Thesis Dissertation 	
				Academic Load	3
				Number of Subjects	1
Dr. Andrea Arreguin Coronado	<ul style="list-style-type: none"> Master's Degree in Nutrigenomics and Personalized Nutrition from the University of the Balearic Islands (2013). Master in Nutrition and Food with mention in Human Nutrition from the Institute of Nutrition and Food Technology, Santiago de Chile (2012). Degree in Nutrition and Food Science from the Ibero-American University of León, Gto. Mexico (2009). 	<ul style="list-style-type: none"> Doctor in Nutrigenomics and Personalized Nutrition from the University of the Balearic Islands (2017). 	<ul style="list-style-type: none"> Master in Physical Activity: Sports Training and Management 	<ul style="list-style-type: none"> SN042 - Cineantropometria 	
				Academic Load	1
				Number of Subjects	1
Dr. Andresa Ribeiro Thomazzoni	<ul style="list-style-type: none"> Master's Degree in Social and Institutional Psychology, federal University of Rio Grande do Sul (2010). Bachelor's Degree in Pedagogy, Federal University of Rio Grande do Sul (2006). Guidance professor at the Distance Learning Center. Counselor at the Federal Institute of Education, Science and Technology of RS. Distance tutor and researcher at the Federal University of Rio Grande du Sul. Clinical psychology at the Institute of Gestalt Psychology of RS. 	<ul style="list-style-type: none"> Doctorate in Computer Science in Education, Federal University of Rio Grande do Sul (2014) 	<ul style="list-style-type: none"> Master in Education Doctorate in Education with a Specialty in Research 	<ul style="list-style-type: none"> FP092 - Methodology of Scientific Research FP102- Strategic Learning and Professional Development FP111 - Analysis of Technological Resources and Creative Activity Designs FP126 - ICT in Education and Learning Theories Master's Thesis 	
				Academic Load	5
				Number of Subjects	5
Dr. Ángel L. Negrón Candelaria	<ul style="list-style-type: none"> Master in Education with a Specialty in Educational Guidance and Counseling University of Turabo, Caguas, Puerto Rico. Bachelor's in Education Secondary with a Specialty in History. Pontifical Catholic University of Puerto Rico, Arecibo Campus. 	<ul style="list-style-type: none"> Doctor in Education with a specialization in Educational Management. Pontifical Catholic University of Puerto Rico, Ponce Campus. (2008) 	<ul style="list-style-type: none"> Doctorate in Education with a Specialty in Research 	<ul style="list-style-type: none"> DO008 - Thesis Proposal DO009 - Thesis Development DO010 - Thesis Dissertation 	
				Academic Load	3
				Number of Subjects	1
Dr. Ángel G. Torres Maldonado	<ul style="list-style-type: none"> Master in Business Administration with a specialty in General Management of the Business Plan as a Final Presentation in May 2008 (Best Choice Radiology Inc.). University of Este, Carolina, Puerto Rico (2005 – 2008). Bachelor's in science in Public Health - Magna Cum Laude Major: Health Services Management. University of Este in Carolina, Puerto Rico. Associate Degree in Radiologist Technology. Universidad Central Del Caribe, Cayey, PR. (School of Medicine). 	<ul style="list-style-type: none"> Doctorate in Education (Instructional Technology and Distance Education). Nova Southeastern University Miami, FL, 	<ul style="list-style-type: none"> Doctorate in Education with a Specialty in Research 	<ul style="list-style-type: none"> DO008 - Thesis Proposal DO009 - Thesis Development DO010 - Thesis Dissertation 	
				Academic Load	3
				Number of Subjects	1
Dr. Angélica Quintero Flórez	<ul style="list-style-type: none"> Master's Degree in Food Technology and Hygiene of the National University of La Plata, Argentina (2013). Degree in Human Nutrition and Dietetics from the National University of Colombia (2003). 	<ul style="list-style-type: none"> Doctor in Health Sciences from the University of Jaen, Spain (2017). 	<ul style="list-style-type: none"> Master in Physical Activity: Sports Training and Management 	<ul style="list-style-type: none"> SN198 - Basic Aspects of Nutrition 	
				Academic Load	1
				Number of Subjects	1

MAIN PROFESSORS					
Professor	CV Summary	Doctorate	Program	Courses Taught	
Dr. Annery Serrano Rodríguez	<ul style="list-style-type: none"> Master's degree in Zoology and Animal Ecology, University of Havana, Faculty of Biology. Bachelor's in Biology, University of Havana, Faculty of Biology. Assistant Professor. Department of Animal and Human Biology. Faculty of Biology. University of Havana. Biology Journal Editor (Biological Sciences, University of Havana) 	<ul style="list-style-type: none"> Doctorate in Biological Sciences (2017) 	<ul style="list-style-type: none"> Doctorate in Projects with a Specialty in Research 	<ul style="list-style-type: none"> DO008 - Thesis Proposal DO009 - Thesis Development DO010 - Thesis Dissertation 	
				Academic Load	3
				Number of Subjects	1
Dr. Antonio Álvarez Baz	<ul style="list-style-type: none"> Degree in Translation and Interpretation in French and Italian from the University of Granada. Diploma in E.G.B. in Spanish and French from the University of the Basque Country. Specialist Course in Adult Education by the University of Granada. Specialist in teaching Spanish as a Foreign Language, sub-specialty for Chinese people. 27 years of experience in teaching Spanish as a Foreign Language. Professor at the Center of Modern Languages at the University of Granada. Has been teaching teachers in different foreign countries and in Spain since 2002. Has several publications, all of them related to the teaching of Spanish as a Foreign Language. He is currently working on three SFL master's degrees (two from the UGR and one from the University of Jaén). 	<ul style="list-style-type: none"> Doctor of Didactics of Language and Literature from the University of Granada. (2002) 	<ul style="list-style-type: none"> Doctorate in Education with a Specialty in Research 	<ul style="list-style-type: none"> DO008 - Thesis Proposal DO009 - Thesis Development DO010 - Thesis Dissertation 	
				Academic Load	3
				Number of Subjects	1
Dr. Antonio Bores	<ul style="list-style-type: none"> Master in High Performance Sports: Strength and Conditioning (2015). Master in High Performance in Team Sports. Byomedic System, FC Foundation Barcelona y INEFC Barcelona (2014). Master in Higher Sports Performance from the Spanish Olympic Committee (2007). Bachelors in Physical Activity and Sport Sciences, mention Sports Training (2003). Professor from the European University of the Atlantic. Numerous papers in specialized sport events. 3er. National Research Prize in Sports Medicine 2012. Reviewer for magazine: <i>Digital Journal of Physical Education and Journal of Sport and Health Research</i>. 	<ul style="list-style-type: none"> Dr. Physical Activity and Sports Sciences: University of Vigo. (2011) 	<ul style="list-style-type: none"> Master in Physical Activity: Sports Training and Management Doctorate in Projects: Projects in Health. 	<ul style="list-style-type: none"> DP004 - Management Techniques for Sports Teams DP006 - Techniques for Management and Leadership in Sports SN229 - Study and Case Resolution for Sports Skills DO008 - Thesis Proposal DO009 - Thesis Development DO010 - Thesis Dissertation Master's Thesis 	
				Academic Load	7
				Number of Subjects	7

MAIN PROFESSORS				
Professor	CV Summary	Doctorate	Program	Courses Taught
Dr. Antonio Cortés	<ul style="list-style-type: none"> • Professor - Music Education Specialty. Faculty of Education Sciences. University of Málaga. (1998) • Graduate in Psychopedagogy. Faculty of Education Sciences, University of Málaga. (2000) • Master in Child Psychology: Clinical, Evolutionary and Educational Aspects. Spanish Association of Behavioral Psychology (AEPC) and Fundación Empresa Universidad de Granada. (FEUGR). (2002-2004) • Specialist Course in Early Child Care University of Málaga. (2001) • Director of Atpsico Cabinet. Health Center with NICA: 43.266. (March 2002 - present) • Work and research lines: Early Care aimed at children from 0 to 6 years of age; Child and Adolescent Psychology; specialist in evaluation, diagnosis and treatment of children with Attention Deficit Hyperactivity Disorder and Behavior Disorder, with interventions aimed at both children and parents through family behavioral therapy; High Intellectual Capacities; Epidemiology and Prevention of Child Psychopathology. University of Málaga Center for Collaboration. • Professor Training Topics: Inclusion, Cooperative Learning, Student at Risk, Behavioral Problems, ADHD, High Abilities, Curriculum Advice, etc., in collaboration with Teacher Training Centers. Two programs are currently being carried out for two public centers dependent on the Motril Teacher Training Center. Granada. 	<ul style="list-style-type: none"> • Doctorate (Program/ University) Doctorate program: "Research and Intervention Program in Developmental Contexts" Department of Evolutionary and Educational Psychology. Faculty of Psychology. University of Málaga. (2016) 	<ul style="list-style-type: none"> • Doctorate in Education with a Specialty in Research 	<ul style="list-style-type: none"> • D0008 - Thesis Proposal • D0009 - Thesis Development • D0010 - Thesis Dissertation
				Academic Load
				3
				Number of Subjects
1				
Dr. Antonio Hernández Fernández	<ul style="list-style-type: none"> • Degree in Philosophy and Literature (Philosophy and Educational Sciences). University of Granada. • Diploma in basic general education teaching. University of Granada. • Specialist in Speech Therapy Polytechnic University of Madrid. • Diploma in Speech Therapy Complutense University of Madrid. • Master in Speech Therapy. University of Vic. • Has been an associate professor at the University of Granada. • Hearing and language professor in the Government of Andalusia. • Assistant doctoral professor. Pedagogy Department of the University of Jaen. • Hired doctoral professor. Pedagogy Department of the University of Jaen. • Has different publications in scientific journals. • Member of scientific committees and councils related to the area of Education and language. • Research lines related to: Diagnosis, identification of special educational needs and rehabilitation in hearing and language, speech therapy and integration support. Inclusive education: constituent aspects, inclusive environments and spaces, differential and normalizing facts. Communication disorders, speech and voice in: sensory, psychic, motor and autism spectrum disabilities. 	<ul style="list-style-type: none"> • Doctor of Pedagogy from the University of Granada.. (2001) 	<ul style="list-style-type: none"> • Doctorate in Education with a Specialty in Research 	<ul style="list-style-type: none"> • D0008 - Thesis Proposal • D0009 - Thesis Development • D0010 - Thesis Dissertation
				Academic Load
				3
				Number of Subjects
1				

MAIN PROFESSORS				
Professor	CV Summary	Doctorate	Program	Courses Taught
Dr. Antonio Pantoja Vallejo	<ul style="list-style-type: none"> Received the Extraordinary Doctorate Award. Bachelor in Philosophy and Education - Philology Division: Head Professor at the University of Jaén. Head of IDEO Research Group (HUM 660). Chief Editor of the scientific journal "MLS-Educational Research". Has supervised 28 doctoral theses and dozens of Master's papers. Has more than 50 published articles, 29 books and 25 book chapters. His latest work is: Pantoja, A. (Coord.) (2015). <i>Basic handbook for the Realization of Dissertations, Theses and Research Works</i>. [Manual básico para la realización de tesis, tesis y trabajos de investigación.] Madrid: EOS. Lines of research: Guidance, mentoring, ICT applied to guidance and mentoring, intercultural education. Is currently the Principal Researcher of the R&D Excellence Project approved in the 2016 call of the Spanish Ministry of Economy and Competitiveness (Ref. EDU2016-75892-P). The universities of Jaén and Granada (Spain), Instituto Politécnico de Coimbra (Portugal) and Queen Mary University of London (United Kingdom) are participants. Several courses given in the different doctoral programs organized by the Department of Pedagogy of the University of Jaén and also by the departments of Musical, Plastic and Body Expression Didactics and Didactics of Science. Has been Coordinator of different Doctoral Programs related to Education and physical activity at the University of Jaén. Has participated in different R+D projects financed in public calls, both national and international. Visits to different centers to carry out research and courses: Cuba, Argentina, Ecuador, France, Argentina, Brazil From 1984 to the present, has attended Congresses, Conferences, Seminars, Meetings, Workshops, etc., has presented works derived from his lines of research in most of them. Member of the Scientific Council of the Instituto Politécnico de Guarda (Portugal). 	<ul style="list-style-type: none"> Doctor in Philosophy and Educational Sciences from the Faculty of Education of UNED. (1997) 	<ul style="list-style-type: none"> Doctorate in Education with a Specialty in Research 	<ul style="list-style-type: none"> DO008 - Thesis Proposal DO009 - Thesis Development DO010 - Thesis Dissertation
				Academic Load
				3
				Number of Subjects
1				
Dr. Maria Aparecida Santos Campos	<ul style="list-style-type: none"> Degree in Physical Education, Catholic Institute of Minas Gerais, Brazil (1991) Researcher at the University of Jaén and Fibromyalgia Association of Jaén, Spain (as of 2010). 	<ul style="list-style-type: none"> Doctor in Educational Sciences, University of Jaen, Spain (2013). 	<ul style="list-style-type: none"> Doctorate in Education with a Specialty in Research 	<ul style="list-style-type: none"> FP127 - Organization and Management of Educational Centers FP124 - Applied Didactics DO008 - Thesis Proposal DO009 - Thesis Development DO010 - Thesis Dissertation
				Academic Load
				5
				Number of Subjects
3				

MAIN PROFESSORS					
Professor	CV Summary	Doctorate	Program	Courses Taught	
Dr. Armando Anaya	<ul style="list-style-type: none"> B.A. in Archeology, National School of Anthropology and History, Mexico City (1980 - 1986) Associate Professor, Department of Archeology, University of Calgary, Canada (2010 - 2013) Associate Professor, Department of Archeology, University of Calgary, Canada (2014 - 2017) Professor - part-time, Universidad Internacional Iberoamericana 2016 Professor/Researcher, Autonomous University of Campeche, CIHS (2006 - Present) Faculty of Anthropological Sciences-UADY 2006 - 2008 	<ul style="list-style-type: none"> Doctorates in Archeology, University of Calgary (1999) 	<ul style="list-style-type: none"> Master in Strategic Management with a Specialty in Management 	<ul style="list-style-type: none"> TR022 - Hotel Business Management TR027 - Cultural Heritage and Tourism TR028 - Environmental Impact on Tourism Activities TR030 - Rural Tourism and Sustainable Development TR031 - Alternative Tourism and Ecotourism 	
				Academic Load	5
				Number of Subjects	5
Dr. Arturo Ortega	<ul style="list-style-type: none"> Executive Education. Service Business Management. ESADE Business School. Electronic Engineer from the University of Barcelona (Spain). Technical Telecommunications Engineer by the University of Ramon Llull, (Spain). Has been an associate professor at the University of Barcelona for more than a decade. Extensive experience in the design and coordination of R&D projects. Has held management positions in technology sector companies. 	<ul style="list-style-type: none"> Doctorate in Electronic Engineering from the University of Barcelona (Spain). (2001) 	<ul style="list-style-type: none"> Master in Strategic Management with a Specialty in Management Master in Strategic Management with a Specialty in Telecommunications Master in Strategic Management with a Specialty in Information Technology Master in Physical Activity: Sports Training and Management 	<ul style="list-style-type: none"> TI011 – Society of Change and Information. TI035 - Architectures, Networks and Distributive Systems Master's Thesis 	
				Academic Load	3
				Number of Subjects	3
Dr. Atahualpa Sosa López	<ul style="list-style-type: none"> Master's in Sciences. Coastal Oceanography. Fisheries Advisor 1996-1999. Autonomous University of Baja California, School of Marine Sciences Marine Biologist. Faculty of Biological Chemistry of the Autonomous University of Campeche. Professor-Researcher C. EPOMEX Institute, Area of Tropical Fishing Resources and Faculty of Chemical-Biological Sciences. Autonomous University of Campeche. 	<ul style="list-style-type: none"> Doctorate in Sciences. Ecology of Continental Aquatic Systems. Fish Ecology Advisory 2002 -2005. University of Montpellier II, France. (2006) 	<ul style="list-style-type: none"> Doctorate in Projects with a Specialty in Research 	<ul style="list-style-type: none"> DO008 - Thesis Proposal DO009 - Thesis Development DO010 - Thesis Dissertation 	
				Academic Load	3
				Number of Subjects	1
Dr. Benjamín Otto Ortega	<ul style="list-style-type: none"> Diploma of Advanced Studies in Biological Oceanography from the University of Brest and IFREMER Departement d'Environnement Marin Profond. Brest, France. Marine Biologist by the Faculty of Biological Chemical Sciences from the Autonomous University, Campeche, Mexico. 	<ul style="list-style-type: none"> Doctorate in Sciences. Biological Oceanography, Microbiology Specialization by the University of Brest and IFREMER Departement d'Environnement Marin Profond. Brest, France. (1999) 	<ul style="list-style-type: none"> Master in Environmental Management and Auditing 	<ul style="list-style-type: none"> MA073 - Natural Areas in the Context of Societies MA074 - Biodiversity MA075 - Natural Spaces: Typology and Processes MA076 - Uses of Natural Spaces MA077 - The Conservation of Species and Natural Areas MA078 - Management of Natural Spaces MA079 - Ecologic Restoration and Landscaping MA080 - Case studies of Management and Conservation of Natural Spaces MA105 - Sea Water MA107 - Sea Water Chemistry 	
				Academic Load	10
				Number of Subjects	10

MAIN PROFESSORS				
Professor	CV Summary	Doctorate	Program	Courses Taught
Dr. Carlos Lago Fuentes	<ul style="list-style-type: none"> • Master's in Physical Activity, Sport and Health from the University of Vigo (2014). • Graduate in Sciences of Physical Activity and Sport from the University of Vigo (2013). • Professor in the European University of the Atlantic 	<ul style="list-style-type: none"> • Doctorate in Sport Sciences, Physical Education and Healthy Physical Activity in University of Vigo. (2019) 	<ul style="list-style-type: none"> • Master in Physical Activity: Sports Training and Management 	<ul style="list-style-type: none"> • SN157 - Control and Prescription of the Physical Activity • SN158 - Physical Activity for Health in Different Diseases • SN228 - Study and Case Resolution • Master's Thesis
				Academic Load
				4
				Number of Subjects
4				
Dr. Carlos Llopis	<ul style="list-style-type: none"> • Master's in Anthropology of Medicine from Rovira I Virgili University (2000) • Bachelors in Traditional Chinese Medicine at the University of Chinese Medicine and Pharmacology in Beijing (1994). • Bachelor's Degree in Pharmacy from the University of Valencia (1961) 	<ul style="list-style-type: none"> • Doctorate in Pharmacy from the University of Valencia (2005). 	<ul style="list-style-type: none"> • Master in Naturopathic Sciences 	<ul style="list-style-type: none"> • MTC001 - Basic Theory (Part I) • MTC002 - Basic Theory (Part II) • MTC003 - Diagnostic • MTC016- Pharmacopoeia 1 • MTC017- Pharmacopoeia 2 • MTC018 - Prescription • MTC019 - Phytotherapy Treatment MI • MTC020 - Dietetics in Traditional Chinese Medicine • MTC025 - Stage • Master's Thesis
				Academic Load
				10
				Number of Subjects
10				
Dr. Carlos Uc Rios	<ul style="list-style-type: none"> • Master's Degree from the IPN Center for Research and Advanced Studies • Bachelor's Degree, Faculty of Engineering, Autonomous University of Campeche. Engineering in Communications and Electronics. • UNACAR Professor, Faculty of Engineering. • Is certified as a Level D Project Management Technician by the International Project Management Association (IPMA) Certification Body, Argentina. • Experience in the planning of 4th and 5th generation cellular networks, coverage analysis, capacity analysis, mainly in the wireless sector (RF). • Outstanding participation in Workshops, Seminars, Congresses. • Author and co-author of several scientific publications. 	<ul style="list-style-type: none"> • Doctor of Science in Electrical Engineering, specializing in telecommunications from the Center for Research and Advanced Studies of the National Polytechnic Institute (CINVESTAV-IPN) Campus Mexico. (2013) 	<ul style="list-style-type: none"> • Doctorate in Projects with a Specialty in Research. • Master in Strategic Management with a Specialty in Management • Master in Strategic Management with a Specialty in Telecommunications • Master in Strategic Management with a Specialty in Information Technology • Master in Project Design, Administration and Management • Doctorate in Projects with a Specialty in Research 	<ul style="list-style-type: none"> • DD026 - Collaborative Work in Virtual Environments • DD118 - Basic Statistics • DO008 - Thesis Proposal • Thesis. • DO009 - Thesis Development • DO010 - Thesis Dissertation • TI013 - Engineering, Strategy and Management of ICT Systems • TI029 - Telecommunications Services • TI030 - Network Security and Management • TI049 - Quantitative Analysis of Tourism • Master's Thesis
				Academic Load
				10
				Number of Subjects
8				

MAIN PROFESSORS				
Professor	CV Summary	Doctorate	Program	Courses Taught
Dr. Carolina Rodríguez Canales	<ul style="list-style-type: none"> • Professor of Physical Education, Sports and Recreation; • Degree in Education; • Doctor of Human Motor Skill Sciences. • Has 11 years of experience in teaching, research, coordination and management of university academic programs, highlighting achievements in the leadership of multidisciplinary teams, permanently fulfilling the objectives of the academic unit and the organization, which has resulted in awards in the administrative, academic and research management areas. • Has improved in the area of morphological (ISAK 1) and functional (FMS 1) evaluation processes for human beings within the sports and health context, as reflected in publications in national and international journals. • Was selected as a National Canoeing Team member with state funding (PRODDAR) for more than 10 years, and was later part of the National Technical Team. • Currently performs their professions in the conduct and participation in processes of curricular actualization, quality assurance and educational innovation and accreditation for educational institutions. 	<ul style="list-style-type: none"> • Doctor of Human Motor Skill Sciences (2019) 	<ul style="list-style-type: none"> • Master in Education 	<ul style="list-style-type: none"> • FP081 - Strategic Planning and Management
				Academic Load
				1
				Number of Subjects
1				
Dr. Ciro Miguel Labrada Silva	<ul style="list-style-type: none"> • Master in Contemporary History, University of Havana (1999) • Bachelor in Education, with a specialization in History and Social Sciences (1981) • Course in Conception and Methodology of Popular Education (2004) • Substitute Professor (temporary) of Sociology at the Federal Institute of Goiania • Research fellow at Conselho Nacional de Pesquisa 	<ul style="list-style-type: none"> • Doctorate in Sociological Sciences, University of Havana, Cuba. (2019) 	<ul style="list-style-type: none"> • Master in Education 	<ul style="list-style-type: none"> • FP103 - Fundamentals of Special Education: Processes of Attention to Diversity • Master's Thesis
				Academic Load
				2
				Number of Subjects
2				
Dr. Claudia de Barros Camargo	<ul style="list-style-type: none"> • Degree in Pedagogy from the Faculty of Social Sciences of Guarantã do Norte-MT (Brazil) • Master's Degree in Educational Sciences from the Autonomous University of Asunción (Paraguay). • 6 years of experience as an assistance professor. • 12 years as a professor of child education (public position) • Has been a teaching assistant in different degrees, bachelor's and diploma courses at the University of Jaén. Done in subjects related to early childhood education, general didactics, teacher training, continuing education. • Published several books, attended conferences and courses on inclusive education and speech therapy, • Lines of research: Diagnosis, identification of special educational needs and rehabilitation in hearing and language, speech therapy and support for integration, inclusive education, communication disorders, language, speech and voice 	<ul style="list-style-type: none"> • Doctor of Social and Legal Sciences. University of Jaén (Spain)(2014) 	<ul style="list-style-type: none"> • Doctorate in Education with a Specialty in Research 	<ul style="list-style-type: none"> • FP118 - Curricular Design and Programming • FP120 - Creation, Adaptation and Evaluation of Materials • FP122 - Fundamentals of Special Education: Processes of Attention to Diversity • DO008 - Thesis Proposal • DO009 - Thesis Development • DO010 - Thesis Dissertation
				Academic Load
				6
				Number of Subjects
4				

MAIN PROFESSORS					
Professor	CV Summary	Doctorate	Program	Courses Taught	
Dr. Claudia Nelly Orozco	<ul style="list-style-type: none"> Bachelor in Nutrition by the University of Guadalajara. 12 years as a university lecturer at public and private universities. 2 years at the master's level. 11 years of experience in kidney and nutritional research. Participant in various committees organizing training sessions on nutrition. Numerous scientific publications in indexed journals, non-indexed journals and newsletters. Coordinator of 2 books on nutrition. Numerous lectures given. Participation in congresses with poster exhibitions and as an assistant. Lines of Research: Kidney nutrition. Member of the Mexican Association of Statistics. Has acquired different scholarships: Splenda Scholarship 2010, CONACyT Scholarship for doctoral studies. Experience in certification by CIEES. Experience in certification by COPAES. 	<ul style="list-style-type: none"> Doctor in Public Health Sciences. University of Guadalajara, Mexico. (2016) 	<ul style="list-style-type: none"> Master in Strategic Management with a Specialty in Management 	<ul style="list-style-type: none"> DD1007 - Health Planning DD1014 - Biostatistics Master's Thesis 	
				Academic Load	3
				Number of Subjects	3
Dr. Cristobal Villanueva	<ul style="list-style-type: none"> Stays in R&D public and private centers in the United Kingdom, Dominican Republic and Italy Participation in projects: ORIENT@CUAL: Creation of a program and a virtual platform of Guidance for the Development of Professional Projects in Professional Training of the educational system. Numerous publications, scientific and technical documents. 	<ul style="list-style-type: none"> Doctorate in Psychopedagogy , University of Almeria, Spain. (2001) 	<ul style="list-style-type: none"> Doctorate in Education with a Specialty in Research 	<ul style="list-style-type: none"> FP121 - Skills Development 	
				Academic Load	1
				Number of Subjects	1
Dr. David Molero López-Barajas	<ul style="list-style-type: none"> Doctor Employed Professor (long-term work contract). Teaching area: Research Methods and Diagnosis in Education (MIDE). Line of research: Emotional Intelligence, Affection, Assessment and Employment. 	<ul style="list-style-type: none"> Doctorate in Psychopedagogy , University of Jaén, Spain. 	<ul style="list-style-type: none"> Doctorate in Education with a Specialty in Research 	<ul style="list-style-type: none"> DO005 - Methodology of Scientific Research (Part I). DO0014 - Methodology of Scientific Research (Part II). DO008 - Thesis Proposal DO009 - Thesis Development DO010 - Thesis Dissertation DO011 - Research Seminar 	
				Academic Load	6
				Number of Subjects	4
Dr. Daliher Marina Villasmil	<ul style="list-style-type: none"> Master in Educational Management, Yacambú University (2012) Expert in E-Learning Processes, Foundation for the Technological Updating of Latin America (2012) Specialist in Telematics and Telematics in Distance Education, National Open University (2009) Diploma in Qualitative Research Methodology, LUZ (2009) Degree in Mathematics Education, mention in Computer Science, Experimental National University Francisco Miranda (2005) 	<ul style="list-style-type: none"> Doctor in Educational from the Experimental Pegagogical University (2016). 	<ul style="list-style-type: none"> Master in Education 	<ul style="list-style-type: none"> Master's Thesis 	
				Academic Load	6
				Number of Subjects	4

MAIN PROFESSORS				
Professor	CV Summary	Doctorate	Program	Courses Taught
Dr. Diego Gómez	<ul style="list-style-type: none"> Health Administrator: Health Services Management emphasis. National School of Public Health, Antioquia University. Medellín, Colombia (2010) Specialist in Occupational Safety from the Colombian Polytechnic Jaime Isaza Cadavid. Medellín, Colombia (2012) Higher Diploma in International Public Health from the National School of Health. Madrid, Spain (2012) Research experience in issues related to the judicialization of health in Colombia, access to health services in specific groups such as diabetic patients and elderly population, social security (health and social protection against labor contingencies), human rights in street children, among others. Experience in virtual and face-to-face teaching and advisor of graduate work, in professionalizing courses, undergraduate and postgraduate courses in the health area. Author of 3 articles in national journals and 2 book chapters. Participation in national research projects on the right to health and access to health services. 	<ul style="list-style-type: none"> Doctor in International Public Health: Specialization in Health Policies and Development by New Lisbon University, Portugal (2018) 	<ul style="list-style-type: none"> Master in Strategic Management with a Specialty in Management 	<ul style="list-style-type: none"> DD1012 - Health Economics DD1013 - Clinical Epidemiology
				Academic Load
				2
				Number of Subjects
2				
Dr. Diego Kurtz	<ul style="list-style-type: none"> Bachelor in Management Processes, INSUL, Brazil. Bachelor in Agronomy by the UFSC, Brazil. Master in Engineering and Knowledge Management, USFC, Brazil. He acts in the area of Project Management and creation of new businesses, with emphasis on innovation and sustainability strategies for several sectors. Responsible of the research and formulation of proposals for private (medium and large companies) and public sectors. He developed and managed all the stages of the life cycle of projects, from their conception, sale, execution/management and final delivery. Significant interest associated to the fields of Management of Projects, Market Intelligence/Competitive and the creation of new businesses 	<ul style="list-style-type: none"> Doctorate in Engineering and Knowledge Management, Federal University of Santa Catarina (Brazil) (2017) 	<ul style="list-style-type: none"> Master in Strategic Management with a Specialty in Management Master in Strategic Management with a Specialty in Telecommunications Master in Strategic Management with a Specialty in Information Technology Doctorate in Projects with a Specialty in Research 	<ul style="list-style-type: none"> TI023 - Study and Case Resolution Master's Thesis
				Academic Load
				2
				Number of Subjects
2				
Dr. Eduardo García (Department Director)	<ul style="list-style-type: none"> Master in Environmental Technology and Engineering from the University of Leon (Spain). Master in Environmental Technology and Engineering from the University of Leon (Spain). Master in Management and Environmental Audits by the University of Leon (Spain). 	<ul style="list-style-type: none"> Doctor in Engineering Projects: Environment, Safety, Quality and Communication at the Polytechnic University of Catalonia (Spain). (2011) 	<ul style="list-style-type: none"> Master in Environmental Management and Auditing 	<ul style="list-style-type: none"> MA208 - Mining and the Environment Master's Thesis
				Academic Load
				2
				Number of Subjects
2				

MAIN PROFESSORS					
Professor	CV Summary	Doctorate	Program	Courses Taught	
Dr. Elena Sanchez	<ul style="list-style-type: none"> Bachelors in Pharmacy from the University of Valencia (2005). Technical Agricultural Engineer, specialty in Agrarian and Food-manufacturing Industries in the University of Navarra, Spain. 	<ul style="list-style-type: none"> Doctorate in Plant Biology in the Universitat de Barcelona (2015). 	<ul style="list-style-type: none"> Master in Environmental Management and Auditing 	<ul style="list-style-type: none"> IP052 - Basic Waste Management MA002 - Ecology MA007 - Noise Pollution MA008 - Natural Resources MA009 - Soil Pollution MA085 - Environment Education and the MSW MA087 - Evolution of the Environment and Sustainable Development MA088 - Historical Evolution of Environmental Education MA090 - Environmental Management and Sustainable Development MA091- Risk Management and Environmental Education MA194 - Basic General Concepts of Environmental Education MA195 – Environmental Education in Formal Education Master's Thesis 	
				Academic Load	13
				Number of Subjects	13
Dr. Elizabeth Caro	<ul style="list-style-type: none"> Master in Business Administration, EUDE Business School, Spain [in progress] Master's in Business, University of Havana, Cuba (2015) Master's Degree in Law and Organizational Psychology, University of Havana, Cuba (2008) Bachelor's in Psychology, University of Havana, Cuba (2009) Professor-Researcher in the University of Havana, Cuba (2011). 	<ul style="list-style-type: none"> Doctorate in Psychological Sciences, University of Havana, Cuba (2021) 	<ul style="list-style-type: none"> Master in Education 	<ul style="list-style-type: none"> FP102- Strategic Learning and Professional Development 	
				Academic Load	1
				Number of Subjects	1
Dr. Elsie Perez	<ul style="list-style-type: none"> Master in Special Education by the Pedagogical Superior Institute "Enrique José Varona" (2000). Higher education professor since 1985 and Senior Lecturer of the University of Holguín (2009). Bachelor in Speech therapy (Phonoaudiology) (1985) Experience in the field of education, with emphasis on Phonoaudiology and special education, acting mainly in special educational needs, inclusion in higher education, speech therapy and phonoaudiology, early childhood education, prevention and methodology of scientific research. 	<ul style="list-style-type: none"> Doctorate in Psychology by the Pedagogical Higher Institute "José de la Luz y Caballero" (2003) 	<ul style="list-style-type: none"> Master in Education 	<ul style="list-style-type: none"> FP103 - Fundamentals of Special Education: Processes of Attention to Diversity 	
				Academic Load	2
				Number of Subjects	2
Dr. Emilio J. Martínez López	<ul style="list-style-type: none"> University Major in Psychology of Physical Activity and Sports. National University of Distance Education (UNED) (2000) Bachelor in Physical Activity, National Institute of Physical Education - Madrid (1990) Certificate of Pedagogical Aptitude (CAP), University of Granada) (1991) Several scientific publications 	<ul style="list-style-type: none"> Doctorate in Physical Education, Medical School of the University of Granada (2001) 	<ul style="list-style-type: none"> Doctorate in Education with a Specialty in Research 	<ul style="list-style-type: none"> FP125 - Physical Activity Applied to Education, Health and Performance 	
				Academic Load	1
				Number of Subjects	1

MAIN PROFESSORS								
Professor	CV Summary	Doctorate	Program	Courses Taught				
Dr. Emmanuel Soriano	<ul style="list-style-type: none"> Major in Education Innovation, Liceo University Pedro de Gante, 2012-2014. Major in Administration (focused on international business), Accountancy and Administration School of the National Autonomous University of Mexico, 2010-2012. Bachelor in Administration, Accountancy and Administration School of the National Autonomous University of Mexico (Bachelor with Honorable Mention) 2004-2008. Mexican Bachelor and Major professor, with experience in Human Resources and Banking, Founding Partner of Business and Education Consultores 	<ul style="list-style-type: none"> Doctorate in Higher Education Sciences, Autonomous University Chapingo, Mexico. (2017) 	<ul style="list-style-type: none"> Master in Strategic Management with a Specialty in Management Master in Strategic Management with a Specialty in Telecommunications Master in Strategic Management with a Specialty in Information Technology Master in Project Design, Administration and Management Master in Project Design, Administration and Management with a Specialty in Architecture and Urban Planning Master in Project Design, Administration and Management with a Specialty in Innovation and Product 	<ul style="list-style-type: none"> DD002 - Management and Cost Control DD014 - Strategic Management and Planning DD036 - Human Resources Auditing DD047 - Financial Management DD121 - International Taxation and Financing DD122 - International Accounting Standards DD123 - Financial Statement Analysis DD124 - Management Accounting DD372- Organizational Leadership and Coaching TR026 - Business Administration and Management Master's Thesis <table border="1"> <tr> <td>Academic Load</td> </tr> <tr> <td>11</td> </tr> <tr> <td>Number of Subjects</td> </tr> <tr> <td>11</td> </tr> </table>	Academic Load	11	Number of Subjects	11
Academic Load								
11								
Number of Subjects								
11								
Dr. Ernesto Bautista	<ul style="list-style-type: none"> Master in Materials Engineering and Science by the Materials Research Institute of Autonomous University of Mexico (UNAM) Degree in Physical from the Autonomous University of Mexico (UNAM) Research Professor for graduate programs in Industrial Engineering and Projects at the Ibero-American International University (UNINI MX). Lines of research in ICT Applications in Education, Data Science, Analysis and modeling of time series, Software applications in the oil industry. Evaluator of RCEA-CONACYT innovation projects. Consultant in Information Technology and Technological Innovation Projects. Teaching experience: Science (Physics, Computer Science), Engineering (Computer Science and Informatics), Management (Creativity and Technological Innovation) Participation in different Software Development and Innovation projects, as well as basic and applied research. Author of scientific articles and book chapters related to ICTs. 	<ul style="list-style-type: none"> Doctorate in Computer Science from the Computer Research Center of the National Polytechnic Institute (IPN) (2005) 	<ul style="list-style-type: none"> Master in Strategic Management with a Specialty in Management Master in Strategic Management with a Specialty in Information Technology 	<ul style="list-style-type: none"> TI016 - Business Intelligence and Document Management TI025 - e-Business and its Integration with Corporate Management Systems <table border="1"> <tr> <td>Academic Load</td> </tr> <tr> <td>2</td> </tr> <tr> <td>Number of Subjects</td> </tr> <tr> <td>2</td> </tr> </table>	Academic Load	2	Number of Subjects	2
Academic Load								
2								
Number of Subjects								
2								
Dr. Ernesto Ferrando Llimós	<ul style="list-style-type: none"> Masters Degree in Applied Linguistics to the Teaching of Spanish as a Foreign Language. University of Jaen. University of Jaén. Graduate in Art History. Participation as a member of the work team in the R&D project BIMAP for the University Pablo de Olavide. More than ten years of experience as a freelance teacher, giving Spanish classes to individuals and groups (young people and adults), as a teacher of Spanish and Hispanic culture. 	<ul style="list-style-type: none"> Doctor in Applied Linguistics. Pablo de Olavide University, Seville (Spain) (2018) 	<ul style="list-style-type: none"> Master in Teaching Spanish as a Foreign Language 	<ul style="list-style-type: none"> FP022 – Communication and Pragmalinguistic Proficiency FP023 – Language, Culture and Bilingualism FP029 - Creation and Adaptation of Materials FP031 - Projects and Tasks Master's Thesis <table border="1"> <tr> <td>Academic Load</td> </tr> <tr> <td>5</td> </tr> <tr> <td>Number of Subjects</td> </tr> <tr> <td>5</td> </tr> </table>	Academic Load	5	Number of Subjects	5
Academic Load								
5								
Number of Subjects								
5								

MAIN PROFESSORS					
Professor	CV Summary	Doctorate	Program	Courses Taught	
Dr. Esther Mena Rodríguez	<ul style="list-style-type: none"> Bachelor's in Philosophy and Arts: Division in Philosophy and Educational Sciences - Section: Psychology from the University of Málaga Specialist Course in Technologies for e-Learning: Tools for online training by the University of Seville Master in Training and Technologies for e-Learning by the University of Seville 14 years as an associate professor in the Department of Educational Research and Innovation Methods at the University of Málaga. Author of several publications related to technology in education, environmental education, mentoring, professional skills, video games and education. Has carried out research visits in Peru for projects related to Education. Lines of research: Guidance and tutoring in the educational system, Attention to diversity and inclusive education in the educational system, Educational technology, educational innovation with ICT, Learning and education: associated factors and strategies, organization and management of educational centers: curriculum design and counseling, Evaluation of centers and teachers for the quality of the teaching-learning process, Teacher training, Methodology of educational research, Education and emotional intelligence, multiculturalism and interculturalism, Labor competence, education and employment. Has three accreditations awarded by ANECA 	<ul style="list-style-type: none"> Doctorate in Audiovisual Communication and Advertising: Technical and expressive processes by the University of Málaga (2013). 	<ul style="list-style-type: none"> Doctorate in Education with a Specialty in Research 	<ul style="list-style-type: none"> DO008 - Thesis Proposal DO009 - Thesis Development DO010 - Thesis Dissertation 	
				Academic Load	3
				Number of Subjects	1
Dr. Estuardo Pérez	<ul style="list-style-type: none"> Mechanical and Electrical Engineer, University of San Carlos de Guatemala (1988) Master in Project Formulation and Evaluation, University of San Carlos de Guatemala (2003) Law degree from University of San Carlos de Guatemala (2012) Degree in Law and Social Sciences, Lawyer and Notary, University of San Carlos in Guatemala (2012) Has more than 8 years of teaching experience in the educational field at postgraduate level, both in applied sciences and law. Work experience in different companies as manager and supervisor of operations and projects. 	<ul style="list-style-type: none"> Doctor in Law, Economics and Business by the International Ibero-American University of Mexico (2020) 	<ul style="list-style-type: none"> Master in Strategic Management with a Specialty in Management 	<ul style="list-style-type: none"> DD099 - National and International Legislation about Mediation and Other Conflict Resolution Procedures DD104 - Conflict Resolution/ Transformation in the Criminal Field DD106 - International Conflict Resolution/ Transformation DD116 - Creation and Internationalization of Family Businesses DD143 - Basic Legal Aspects of the Family Business 	
				Academic Load	5
				Number of Subjects	5

MAIN PROFESSORS					
Professor	CV Summary	Doctorate	Program	Courses Taught	
Dr. Eugénie Eyeang	<ul style="list-style-type: none"> Bachelor's in Secondary Education. Series B (Economy and Social). Mention: Remarkable. University Diploma of Literary Studies (DUEL, Spanish acronym), Faculty of Arts and Human Sciences (FLSH, Spanish acronym), Omar Bongo University, FLSH, Libreville, Gabon. Bachelor of Arts, Spanish Option, Omar Bongo University, Libreville, Gabon Diploma of Hispanic Studies (DEH, panish acronym), University of Salamanca, International Courses, Spain. Lecturer in Language Didactics at the Ecole Normale Supérieure de Libreville (Gabon) 33 years of experience as a Spanish teacher, Spanish didactics and methodology Publishing director of the CRAAL scientific journal. CRAAL director (Center of Applied Research for Art and Languages, <i>Centro de Investigación Aplicada para el Arte y Lenguas</i>), ENS, Libreville. Has published several international papers about Spanish, learning methodologies, Gabonese society, learning foreign languages. Member of the Scientific Committee AULA (University of Salamanca), Education Forum (University of Valladolid). Member of the Symposium Scientific Committee: Education and Development in Africa (University of Valladolid) Vice-President of the Organizing Committee of the First Forum on Africa, Education and Development. Language, Literature and Educational Sciences in the Educational Systems of Sub-Saharan Africa (University of Salamanca). Lines of teaching: Foreign Language Didactics, Linguistics, Epistemology of Language Teaching, Community Practice, Handbook Design, Program Development, Socio-Cultural Knowledge Building. 	<ul style="list-style-type: none"> Doctorate in Linguistics and Language Teaching, Stendhal University, Grenoble III, Grenoble-Alpes (2010). 	<ul style="list-style-type: none"> Doctorate in Education with a Specialty in Research 	<ul style="list-style-type: none"> DO008 - Thesis Proposal DO009 - Thesis Development DO010 - Thesis Dissertation 	
				Academic Load	3
				Number of Subjects	1
Dr. Federico Fernández	<ul style="list-style-type: none"> Doctor of Philosophy and Educational Sciences, University of Barcelona, Spain (1990). Bachelors in Educational Sciences. Research Professor of Project Engineering, Polytechnic University of Catalonia, Spain (2003-present). Director of the Laboratory of visual image of the School of Industrial Engineers. Course "Training for Teachers" - FUNIBER (2015) Course "Training for Directors of Thesis" - FUNIBER (2015) 	<ul style="list-style-type: none"> Doctor in Educational Sciences from the University of Barcelona, Spain (1990). 	<ul style="list-style-type: none"> Master in Teaching Spanish as a Foreign Language Master in Project Design, Administration and Management Master in Project Design, Administration and Management with a Specialty in Innovation and Product 	<ul style="list-style-type: none"> DD077 - Project Communication Master's Thesis 	
				Academic Load	2
				Number of Subjects	2
Dr. Felipe García Pinillos	<ul style="list-style-type: none"> Bachelors in Physical Activity and Sport Sciences (University of Granada, Spain). Specialist in Re-adaptation and prevention of sports injuries (University of Jaén, Spain). Master's Degree in Research and Teaching in Physical Activity and Sport (University of Jaén, Spain). 	<ul style="list-style-type: none"> Doctor in Physical Activity and Sports Sciences, University of Jaén (Spain) (2016). 	<ul style="list-style-type: none"> Master in Physical Activity: Sports Training and Management 	<ul style="list-style-type: none"> SN155 - Contextualization of Physical Activity and Exercise in the Health Framework Master's Thesis 	
				Academic Load	2
				Number of Subjects	2
Dr. Ferdinand Arce Santiago	<ul style="list-style-type: none"> Master of Arts in Organizational Psychology by the Bayamon Central University (July 1999 - March 2001). Bachelor in Biology from the Interamerican University of Puerto Rico, Arecibo Campus (August 1984 - May 1996). Associate Degree in Police Sciences by the John Jay College of Criminal Justice - Gurabo, Puerto Rico (October 1994 - October 1995). Emergency Medical Technician by the Vocational School Domingo Aponte Collazo, Lares, Puerto Rico (October 2003) 	<ul style="list-style-type: none"> Doctor of Philosophy in Clinical Psychology by the Pontifical Catholic. University of Puerto Rico (2010). 	<ul style="list-style-type: none"> Doctorate in Education with a Specialty in Research 	<ul style="list-style-type: none"> DO008 - Thesis Proposal DO009 - Thesis Development DO010 - Thesis Dissertation 	
				Academic Load	3
				Number of Subjects	1

MAIN PROFESSORS				
Professor	CV Summary	Doctorate	Program	Courses Taught
Dr. Fermín Ferriol	<ul style="list-style-type: none"> • Master in Administration from the University of Havana. • 35 years as a professor and consultant. • Bachelor's in Political Economy. • Training at the (ESADE) (School of Business Administration), Barcelona, Spain. • Training at the University of Lower Saxony, Germany. • Prepared as a Consultant by a group of North American professors and consultants. Havana. • Thesis Director Training Course (FUNIBER, 50 hours). • Course: "Training in Teaching in Virtual Learning Environments (FUNIBER 175h) • He has received more than 45 postgraduate degrees related to Pedagogy, Economics, Philosophy, Administration, Marketing, Financial Administration, Negotiation, Accounting, Business Strategy Design, Market Analysis, Organizational Development, International Economic Relations, Business Management, Human Resource Management, Quality, Leadership, Organizational Learning and Research Methodology. • Coordinator of the National Group of Experts of the universities that advise the ministries and the provinces in the introduction of the Direction by Objectives and the Strategic Planning. • Coordinator of the experience on the introduction of Integrated Strategic Management in 9 of the most developed companies in the country, which was carried out with foreign advice. • Coordinator of the group of Higher Education teachers who teach in the National Art School of the Ministry of Higher Education. • Coordinator of Doctorates at the Universidad Internacional Iberoamericana (UNINI-Mexico) until now. • He has received different medals, diplomas, distinctions of professional merit. • He has written different scientific articles related to Business Development. 	<ul style="list-style-type: none"> • Doctorate in Education from the University of Havana (University Management). (2012) 	<ul style="list-style-type: none"> • Master in Strategic Management with a Specialty in Management • Master in Strategic Management with a Specialty in Telecommunications • Master in Strategic Management with a Specialty in Information Technology • Master in Physical Activity: Sports Training and Management • Doctorate in Projects with a Specialty in Research • Doctorate in Education with a Specialty in Research 	<ul style="list-style-type: none"> • DD159 - Introduction to the New Marketing • DD1009 - Heath Marketing • DO011 - Research Seminar • DP003 - Sports Marketing. Applications • DP006 - Techniques for Management and Leadership in Sports • DO008 - Thesis Proposal • DO009 - Thesis Development • DO010 - Thesis Dissertation • TR024 - Management Techniques and Organizational Leadership • TR046 - Strategic Management of Human Resources
				Academic Load
				10
				Number of Subjects
8				

MAIN PROFESSORS				
Professor	CV Summary	Doctorate	Program	Courses Taught
Dr. Fernando Calahorro	<p>ACADEMIC EXP.:</p> <ul style="list-style-type: none"> • First Certificate English, B2 - "Grade B". Cambridge University 2011. • Master's Degree in Research and Teaching in Physical Activity and Health Science, University of Jaen (2008 -2009). • 3 month doctoral visit to the Physical Exercise and Health Laboratory, Faculty of Human Motorskill Sciences (October - December 2013, Lisbon - Portugal). • 3 month research visit to the Biodynamics and Body Composition Laboratory (University of Málaga; April-June 2014). • Doctor in Physical Activities and Sports Sciences with International Excellence Mention, "Patterns, Fractionation and Guidelines of Physical Activity: the Relevance of School Physical Activity on Peak Oxygen Consumption" - Outstanding Cum Laude unanimously - (2015). • Accredited as a Doctoral Assistant Professor (ANECA, 2016). <p>PROFESSIONAL EXP.:</p> <ul style="list-style-type: none"> • Physical Football Trainer 3rd Division (2006 - 2009). • Physical trainer of the Spanish National Women's Kinball Team (2012-2013). <p>TEACHING EXP.:</p> <ul style="list-style-type: none"> • Teacher in Infant and Primary Education and in the specialty of Physical Education at the University School "Sagrada Familia" - Center adscribed to the Univ. of Jaen. Subject: Didactics of Physical Education (2011). • Bilingual Physical Education Teacher in High School. Andalusian Board (2010-2016). • Teacher of Physical Education in the cycle of Intermediate Degree (Technician in the Leadership of Physical Activities in the Natural Environment) and Higher Degree (Technician in Physical Activities and Sport Entertainment). Subjects: Biological Foundations and Basics of Physical Conditioning; Individual Sports; Games and Physical-Recreational Activities; Group Bicycle and Commute Leadership, Visiting and Safety in the Natural Land Environment. (2011-2012 and 2014-2015) Andalusian Board. 	<ul style="list-style-type: none"> • Bachelor's in Physical and Sports Sciences with Mention of International Excellence, University of Jaén (2015) 	<ul style="list-style-type: none"> • Master in Physical Activity: Sports Training and Management 	<ul style="list-style-type: none"> • DO008 - Thesis Proposal • DO009 - Thesis Development • DO010 - Thesis Dissertation
				Academic Load
				3
				Number of Subjects
				1
Dr. Franahid D'silva Signe	<ul style="list-style-type: none"> • Master in University Teaching, Universidad Nacional Experimental de los Llanos Occidentales Ezequiel Zamora, Venezuela (2009) • Political scientist graduated from Universidad de los Andes, Venezuela (1999) • Assistant professor at the Universidad Nacional Abierta, Venezuela, (as of 2004). • Contract Professor at Universidad Nacional Experimental de los Llanos Occidentales Ezequiel Zamora, Venezuela (1999-2003) 	<ul style="list-style-type: none"> • Doctorate in Education, Universidad Nacional de Educación a Distancia de Panamá, Panamá (2019) 	<ul style="list-style-type: none"> • Master in Education 	<ul style="list-style-type: none"> • FP112 - Design and Evaluation of Training Proposals Based on ICT • FP182 - Knowledge Management and Innovation within Education • Master's Thesis
				Academic Load
				3
				Number of Subjects
				3

MAIN PROFESSORS				
Professor	CV Summary	Doctorate	Program	Courses Taught
Dr. Francisco de Paula Rodríguez Miranda	<ul style="list-style-type: none"> • Degree in Psychopedagogy from the University of Huelva. • Master's degree in University Teaching from the University of Huelva. • Master's degree in Intercultural Education from the University of Huelva. • Areas of Knowledge: Theory and History of Education, Didactics and School Organization. • Lecturer at the University of Huelva and the National University of Distance Education. • Has published several articles, books and professional exhibitions on education, university research, learning by research, and digital resources for teaching. • Lines of research: Attention to diversity and inclusive education in the education system. Educational technology, Educational Innovation with ICT. Organization and Management of Educational Centers Curriculum design and counseling. Evaluation of centers. Teacher's training. Evaluation of centers and teachers for the quality of the teaching and learning process, Methodology of Educational Research. Multiculturalism and interculturalism. 	<ul style="list-style-type: none"> • Doctorates in Education democracy and Diversity: Strategies and Resources for Research from the University of Huelva (2009) 	<ul style="list-style-type: none"> • Doctorate in Education with a Specialty in Research 	<ul style="list-style-type: none"> • DO008 - Thesis Proposal • DO009 - Thesis Development • DO010 - Thesis Dissertation
				Academic Load
				3
				Number of Subjects
Dr. Grisel Rivera	<ul style="list-style-type: none"> • Master in Health Sciences with a Specialty in Adults and Seniors Curriculum and Teaching. University of Puerto Rico (1992) • Bachelor in Science. Interamerican University, Metropolitan Campus, PR. (1982) • Vocational Trade Teacher Certification (Health Related Occupations). Education Department of PR. • Professor of Health Related Occupations in Technological Institutes. Education Department of PR. (2013-2019) • Vocational General Supervisor. Education Department of PR. (2014-2020) • Associate Professor Teacher Preparation Program for the Secondary School Nursing Program - Alternate. University of Puerto Rico PPMES (as of 2009) • PPMES Director and Coordinator University of Puerto Rico. (2010-2013) • Has offered several courses on Educational Philosophy, Growth and Human Development, Social Aspects of Education, among others. • Author of several published books, having participated in such online research as: Educational Aspects in the Teaching area and their needs of professional development for the teaching-learning improvement, and the health area as well, focusing on the curricular aspects of the Nursing Programs at the Bachelor and Master levels and its impact within the necessary competencies for the profession. 	<ul style="list-style-type: none"> • Doctorate in Special Education and Transition Services. Interamerican University, Metropolitan Campus, PR. (2006) 	<ul style="list-style-type: none"> • Doctorate in Education with a Specialty in Research 	<ul style="list-style-type: none"> • DO008 - Thesis Proposal • DO009 - Thesis Development • DO010 - Thesis Dissertation
				Academic Load
				3
				Number of Subjects
Dr. Horacio García Mata	<p>Teaching activity in:</p> <ul style="list-style-type: none"> • Autonomous University of Tamaulipas, Doctorate in Education. • Miguel Hidalgo Regional University, Master's in Administration. • Tamaulipas Normal Higher Education School, Master's in Psychopedagogy • Tamaulipas Normal Higher Education School, Bachelor's Degree in Educational Psychology • Tamaulipas Normal Higher Education School, Bachelor's Degree in Physical Education. • Specialist in the teaching of workshops and lectures related to the: "team building" in business and the educational area. • Physical Education Coordinator at the Education Secretariate in Tamaulipas 	<ul style="list-style-type: none"> • Doctorate in Education (2015) 	<ul style="list-style-type: none"> • Doctorate in Projects with a Specialty in Research 	<ul style="list-style-type: none"> • DO008 - Thesis Proposal • DO009 - Thesis Development • DO010 - Thesis Dissertation
				Academic Load
				3
				Number of Subjects
				1

MAIN PROFESSORS				
Professor	CV Summary	Doctorate	Program	Courses Taught
Dr. Inés María Muñoz Galiano	<ul style="list-style-type: none"> Interim substitute professor, University of Jaen. Assistant Professor, University of Seville. Certified in Social Education (2007). Pedagogic Competence Certificate (CAP). University Expert in Gerontology: socio-educational intervention in seniors (2001). Bachelor in Pedagogy (2001). 	<ul style="list-style-type: none"> Doctorate in Pedagogy, University of Granada (2008) 	<ul style="list-style-type: none"> Doctorate in Education with a Specialty in Research 	<ul style="list-style-type: none"> FP127 – Organization and Management of Educational Centers
				Academic Load
				1
				Number of Subjects
1				
Dr. Irania Malaver	<ul style="list-style-type: none"> Master in Linguistics, Central University of Venezuela (1998) Advanced Degree in Anthropology (1989) Final Project Director, Central University of Venezuela. Collaborating Professor of the Fundació per a la Universitat Oberta de Catalunya 	<ul style="list-style-type: none"> Doctorate in Applied Linguistics, University of Alcala, Spain. (2009) 	<ul style="list-style-type: none"> Master in Teaching Spanish as a Foreign Language 	<ul style="list-style-type: none"> FP019 - Second language acquisition FP027 - Methodological FP033 - Curriculum Design and Programming: Theory and Practice Master's Thesis
				Academic Load
				4
				Number of Subjects
4				
Dr. Isabel Sánchez López	<ul style="list-style-type: none"> Master in Teaching Spanish as a Foreign Language Santander, Menéndez Pelayo International University (Spain), 2005-2007. University expert in teaching Spanish as a Foreign Language. Santander, Menéndez Pelayo International University (Spain), 2004. Bachelor Degree in Hispanic Philology. Faculty of Philosophy and Literature, the University of Granada (Spain). Her lines of work and research are in applied linguistics to the teaching / learning of Spanish and Lexicography. Has published works of various disciplines , but mainly in Lexicography teaching or pedagogical. Has participated and coordinated programs for the training of teachers in Spain and outside of it. Has issued public conferences in Spain and outside of it. Her educational work has been carried out in Spanish and foreign universities and at the Cervantes Institute. She currently works as a professor of Spanish at the University of Jaen and as coordinator of Spanish in this same center. 	<ul style="list-style-type: none"> Doctorate in Spanish Philology. University of Jaén, Spain. (2011) 	<ul style="list-style-type: none"> Master in Teaching Spanish as a Foreign Language Doctorate in Education with a Specialty in Research 	<ul style="list-style-type: none"> FP021 - Learning Factors DO008 - Thesis Proposal DO009 - Thesis Development DO010 - Thesis Dissertation
				Academic Load
				4
				Number of Subjects
2				
Dr. Jesús Arzamendi Sáez de Ibarra	<ul style="list-style-type: none"> Bachelor's in Romance Philology from the University of Deusto (Spain). Professor of General Linguistics, Semiotics and Semantics at the University of Deusto (1973- -1983). Professor of Pedagogy in Language, Linguistics, Evaluation of Bilingual Education Programs and Semiotics at the University of the Basque Country (1981-2005). Director of the Institute of Education Sciences at the University of the Basque Country (1988-1991). Director of the Masters "Teaching Spanish as a Foreign Language" (1992-1996). Director of the Master "English Teachers training in a virtual campus" (1998-2001). 	<ul style="list-style-type: none"> Doctor in Philosophy and Literature - Section: Romance Philology from the University of Deusto (Spain). (1983) 	<ul style="list-style-type: none"> Master in Teaching Spanish as a Foreign Language Doctorate in Education with a Specialty in Research 	<ul style="list-style-type: none"> FP020 - Individual Factors in Learning FP032 - Evaluation of the Learning Process DO008 - Thesis Proposal DO009 - Thesis Development DO010 - Thesis Dissertation Master's Thesis
				Academic Load
				6
				Number of Subjects
4				
Dr. Jesús Sánchez	<ul style="list-style-type: none"> MS in Computer Science, Information Systems, Pace University of New York, New York. MS in Education, The City University of New York (CUNY), New York City. Microsoft Certified Professional (MCP). Coordinator of the School of Technology, professor of computer science at the Catholic University of Puerto Rico, Mayagüez (2011-present). Title V Activity Coordinator, Project PUCPR Mayagüez PR (2007-2010). Coordinator of Faculty Title V, Project PUCPR Mayagüez PR (2005-2007). Director of the School of Business Administration, Catholic University of PR, Mayagüez (1998-2000). 	<ul style="list-style-type: none"> Doctor in Business Administration, Pontifical Catholic University of Puerto Rico, Ponce Puerto Rico Campus. (2013) 	<ul style="list-style-type: none"> Doctorate in Projects with a Specialty in Research 	<ul style="list-style-type: none"> DO008 - Thesis Proposal DO009 - Thesis Development DO010 - Thesis Dissertation
				Academic Load
				3
				Number of Subjects
1				

MAIN PROFESSORS				
Professor	CV Summary	Doctorate	Program	Courses Taught
Dr. Jon Arambarri	<ul style="list-style-type: none"> MBA, Institute of Applied Economics of UPV-EHU. Senior Engineer in Telecommunications Engineering School of Bilbao. Director of R&D in www.virtualware.es; multimedia, 3D, animation and Virtual Interactive Environments. He has worked as R&D director to www.gowex.com: Telecommunication Services for companies. Has made numerous publications on his specialty such as: information systems, telecommunications, collaborative virtual work, environment, management of knowledge 	<ul style="list-style-type: none"> Doctor in the management of engineering projects from the Polytechnic University of Catalonia (Spain). (2014) 	<ul style="list-style-type: none"> Master in Strategic Management with a Specialty in Management Master in Strategic Management with a Specialty in Telecommunications Master in Strategic Management with a Specialty in Information Technology 	<ul style="list-style-type: none"> TI004/DD163 - International Marketing TI015 - Electronic and Legislation Security TI023 - Study and Case Resolution TI026 - Telecommunications Marketing TI027 - Technical-Business Structure of Telecommunications TI028 - Telecommunications Networks TI031 - Telecommunications Marketing Regulations TI043 - Management and Administration of IT Projects Master's Thesis
				Academic Load
				8
				Number of Subjects
8				
Dr. Jorge Crespo	<ul style="list-style-type: none"> Civil Engineering from the Higher Polytechnic Institute José Antonio Echeverría (Cuba) Bachelor (Approval) by the Ministry of Education, Spain in 2010 13 years experience teaching Civil and Industrial Engineering and Architecture. Specialist in computational modeling and simulation, development of automated systems for decision-making and expert systems and management processes. Participated in competitive and non-competitive R&D addressed to administrations and public and private entities in Spain. Author and co-author of scientific books and articles related to civil engineering, numerical methods, structures. 	<ul style="list-style-type: none"> Doctor in Civil Engineering from the University of Cantabria, Santander (Spain). (2011) 	<ul style="list-style-type: none"> Master in Strategic Management with a Specialty in Management Master in Strategic Management with a Specialty in Telecommunications Master in Strategic Management with a Specialty in Information Technology Master in Project Design, Administration and Management Master in Project Design, Administration and Management with a Specialty in Architecture and Urban Planning Master in Project Design, Administration and Management with a Specialty in Innovation and Product 	<ul style="list-style-type: none"> DD076 - Management Without Distances DD119 - Statistical Sampling TI036 - Web Technology and Engineering TI041 - Business Software Process TR036 - Strategy and Tourism Businesses on the Internet TR037 - ICT in the Tourism Industry Master's Thesis
				Academic Load
				7
				Number of Subjects
7				

MAIN PROFESSORS				
Professor	CV Summary	Doctorate	Program	Courses Taught
Dr. José Bazurto	<ul style="list-style-type: none"> Master in Business Administration from Universidad del Mar, Chile; Specialist in Curriculum Design by Competences from the Universidad del Mar, Chile; Electrical Engineer from ULEAM, Ecuador. Professor in Project Management by the ULEAM and by the University of Guayaquil. 	<ul style="list-style-type: none"> Doctor in Projects by the Universidad Internacional Iberoamericana in Mexico (2018) 	<ul style="list-style-type: none"> Doctorate in Projects with a Specialty in Research Master in Project Design, Administration and Management Master in Project Design, Administration and Management with a Specialty in Architecture and Urban Planning Master in Project Design, Administration and Management with a Specialty in Innovation and Product 	<ul style="list-style-type: none"> DD075 - Trust Management: Risk and Quality DD077 - Project Communication DD235 - Introduction to Project Design From Conflict to Technical Problem DD236 - Systems Design - Project Solutions DD237 - Desired Service and Conditions for Provision DD238 - System Solution: Functional Analysis in the Project DD239 - Roles of People in the Project DD240 - Project Security and Reliability DD241 - Environmental Viability of the Project DD242 - Project Proposal: Specifications DD243 - Project Draft Preparation
				Academic Load
				11
				Number of Subjects
				3
Dr. José Hidalgo	<ul style="list-style-type: none"> Education as a graduate in Biological Sciences with a subsequent Doctorate from the University of Granada in Education, specifically within the Department of Didactics of Experimental Sciences. From 1999 onwards, has been a full-time head professor in the Department of Didactics of Experimental Sciences at the "Sagrada Familia" University Centre in Úbeda (attached to the University of Jaén), teaching various subjects related to this area. 	<ul style="list-style-type: none"> Doctor in Population Biology, Aquaculture and Environment. University of Granada (2006) 	<ul style="list-style-type: none"> Doctorate in Education with a Specialty in Research 	<ul style="list-style-type: none"> DO008 - Thesis Proposal DO009 - Thesis Development DO010 - Thesis Dissertation
				Academic Load
				3
				Number of Subjects
				1
Dr. José A. Medina	<ul style="list-style-type: none"> MScHE, Chemical Engineering, Specialty in: Electrochemical Engineering, University of Puerto Rico, Mayagüez PR, 1975-1977 Team Leader, Certified Consultant TSR- IMB Puerto Rico, 1997-2010. Advisor, Sales Representative Advisory, IBM Puerto Rico, 1993-1996 Pharmaceutical Industry Specialist / Consultant, IBM Puerto Rico 1989-1992. Systems Engineer Advisor Level, IBM Puerto Rico, 1985-1989. Research and Development Engineer (R&D), IBM Vermont, U.S. 1979-1985. 	<ul style="list-style-type: none"> Edd., Education, Specialty in: Instructional Technology and Distance Education, NOVA Southeastern University (2013) 	<ul style="list-style-type: none"> Doctorate in Education with a Specialty in Research 	<ul style="list-style-type: none"> DO008 - Thesis Proposal DO009 - Thesis Development DO010 - Thesis Dissertation
				Academic Load
				3
				Number of Subjects
				1

MAIN PROFESSORS					
Professor	CV Summary	Doctorate	Program	Courses Taught	
Dr. José Antonio Trigueros Pina	<ul style="list-style-type: none"> • Degree in Economics and Business Studies from the University of Murcia. Business Branch. • Assistant and tenured professor at the University of Alicante and the University Miguel Hernández. In the Bachelor's as in the Doctorate's. • Member of the promotional team of the Operations Research Center of the Miguel Hernández University • Has published several books on Accounting and Auditing. • Several published articles related to Auditing and Accounting. • Director of the School of Economics from the Ilte. College of Alicante Economists. • Director of the Master's Degree in Auditing and Business Management at Miguel Hernández University. • Director of the Financial Economics and Accounting Division of the Pre-departmental Unit for Economic and Financial Studies of the Miguel Hernández University. • Coordinator of the "Experimental Center for Economic and Financial Studies" from the Faculty of Social and Legal Sciences. 	<ul style="list-style-type: none"> • Doctorate in Economic and Business Sciences from the Complutense University of Madrid. (1995) 	<ul style="list-style-type: none"> • Doctorate in Projects with a Specialty in Research 	<ul style="list-style-type: none"> • DO008 - Thesis Proposal • DO009 - Thesis Development • DO010 - Thesis Dissertation 	
				Academic Load	3
				Number of Subjects	1
Dr. José F. Sanz Requena	<ul style="list-style-type: none"> • Degree in Physics from the University of Valladolid • Research career in Applied Physics. • Professor at the Miguel de Cervantes European University. • High school and Bachelor's professor. • Numerous publications in different magazines and seminars on environmental science. 	<ul style="list-style-type: none"> • Doctor in Physical Sciences from the University of Valladolid (Spain) (1995) • Doctorate Program in Atmospheric Physics • Accredited by ANECA 	<ul style="list-style-type: none"> • Master in Environmental Management and Auditing • Master in Strategic Management with a Specialty in Management 	<ul style="list-style-type: none"> • IP053 - Atmospheric Contamination Treatment • MA005 - Atmospheric Pollution • MA095 - Treatment of Gaseous Effluents • MA245 - Agreements, Negotiations and Instruments for Climate Change • MA246 - Vulnerability and Adaptation to Climate Change • MA247 - Climate Change Mitigation • MA248 - Science and Politics of Climate Change • MA282 - Climate Change Mitigation • Master's Thesis 	
				Academic Load	8
				Number of Subjects	8
Mr. José Manuel Martos Ortega	<ul style="list-style-type: none"> • Specialist in didactic and pedagogical methods. • Researcher in Didactics and School Organization for the University of Granada. • Member of the editorial team of the <i>Profesorado</i>, a Journal on Curriculum and Teacher Education. • Papers presented at conferences, seminars, workshops and/or national or international courses on professional qualifications, socio-educational professionalism, social skills, school failure and educational exclusion, pedagogy in retirement homes and at home. • 13 years of teaching activity • Lines of research: Attention to diversity and inclusive education in the education system. Learning and Education. Associated factors and strategies. Organization and Management of Educational Centers Curriculum design and counseling. Evaluation of centers. Teacher's training. Educational Research Methodology (Qualitative) Occupational Competence, Education and Employment 	<ul style="list-style-type: none"> • Doctorate Program in Didactics and School Organization by the University of Granada (2014) 	<ul style="list-style-type: none"> • Doctorate in Education with a Specialty in Research 	<ul style="list-style-type: none"> • DO008 - Thesis Proposal • DO009 - Thesis Development • DO010 - Thesis Dissertation 	
				Academic Load	3
				Number of Subjects	1

MAIN PROFESSORS				
Professor	CV Summary	Doctorate	Program	Courses Taught
Dr. José Zavala	<ul style="list-style-type: none"> • Master's Degree / Master in the teaching of mathematics with a terminal exit in Mathematics Education / Autonomous University of the State of Morelos. • Master's Degree in Education Sciences/ Institute of University Studies, Civil Association, Chiapas, Mexico. • Specialization in the Teaching of Mathematics with Terminal Outputs in Mathematical Education and Educational Computing / Autonomous University of the State of Morelos, Mexico. • Bachelor's Degree/ Engineer in Chemical Processes, Specialty in Petrochemical Processes/ Carmen Autonomous University / Faculty of Chemistry, Campeche, Mexico. 	<ul style="list-style-type: none"> • Doctorate in Chemical Engineering/ Technological Institute of Celaya, Guanajuato, Mexico. (2005) 	<ul style="list-style-type: none"> • Master in Strategic Management with a Specialty in Management • Master in Environmental Management and Auditing 	<ul style="list-style-type: none"> • DD125 - Total Quality Costs • IP078 - Background and Actual Situation of Integrated Management • IP9001 - Introduction and Fundamentals of Integrated Management Systems • IP9002 - Advantages and Difficulties of The Integration of Systems, Grades, Modes and Integration System Models • MA028 - Potentially Contaminated Marine Ecosystems • MA029 - Environmental Factors that Affect Pollutants • MA030 - Contaminating Agents • MA031 - Toxicology • Master's Thesis
				Academic Load
				9
				Number of Subjects
9				
Dr. Josué Pacheco Castillo	<ul style="list-style-type: none"> • Bachelor in Nursing Sciences by the University of Puerto Rico Medical Science Campus, School of Nursing. • Master in Nursing Sciences with specialization in nursing administration and nursing education by the University of Puerto Rico, Medical Sciences Campus, School of Nursing. • Over 21 years of professional experience in nursing administration, education and research. • Staff administration and supervision. • Staff development and training. • Policy and procedure handbook development. • Protocol development. • Bilingual: Spanish and English. • Skills in the use of MS Office (Word) and Internet Explorer. • Preparation of reports related to teaching and the area of health. • Nurse practitioner with extensive experience in adult and cornflower patient care in the areas of medicine, psychiatry and intensive care of the dying patient. • Evaluation and management of medical records. • Evaluation of educational programs and program accreditation processes. • Verbal and written communication skills. • Extensive experience in research and research ethics. • Experience in the process of evaluating student learning. • Lines of research: Didactics of physical education, health and performance, attention to diversity and inclusive education in the education system, learning and education: Associated factors and strategies, organization and management of educational centers, educational technology, educational innovation with ICT, teacher training, evaluation of centers and teachers for the quality of the teaching-learning process, methodology of educational research, education and health projects, education and emotional intelligence, management of cultural diversity, labor competence, education and employment. 	<ul style="list-style-type: none"> • Doctor in Education with a specialty in Educational Administration from the Inter-American University of Puerto Rico, Metropolitan Campus, San Juan, Puerto Rico. (2007) 	<ul style="list-style-type: none"> • Doctorate in Education with a Specialty in Research 	<ul style="list-style-type: none"> • D0008 - Thesis Proposal • D0009 - Thesis Development • D0010 - Thesis Dissertation
				Academic Load
				3
				Number of Subjects
1				

MAIN PROFESSORS					
Professor	CV Summary	Doctorate	Program	Courses Taught	
Dr. Juan Luis Martín	<ul style="list-style-type: none"> Family Mediation Specialist, College of Psychologists of Vizcaya (Spain). Master's degree in Mental Health and Psychotherapy Techniques at the University of Deusto. Degree in Psychology from the University of the Basque Country (Spain). Bachelor's degree in Psychology from the University of the Basque Country (Spain). Professor as of 2005 in education, special education, psychology. Collaborated in different subjects such as psychology, and psychological development in families. Author and co-author of articles and chapters on psychology, family relationships, (harassment) "bullying", and drug use. 	<ul style="list-style-type: none"> Doctorate in Psychological Treatment, Assessment and Personality, University of the Basque Country, Spain. (2001) 	<ul style="list-style-type: none"> Master in Strategic Management with a Specialty in Management 	<ul style="list-style-type: none"> DD097/DD098 - Mediation DD101 - Conflict Resolution/ Transformation in the Family Master's Thesis 	
				Academic Load	3
				Number of Subjects	3
Dr. Juan Manuel Méndez Garrido	<ul style="list-style-type: none"> Degree in Philosophy and Educational Sciences from the National University of Distance Education Diploma in General Basic Education Teachers Diploma in General Basic Education Teachers by the University of Seville Professor at the University of Huelva, attached to the Department of Education in the Knowledge area of Research and Diagnostic Methods in Education from the University of Huelva, Researcher of the "Educational Orientation Research Group" (GIOE) Has been a researcher in the "Studies Group and Educational Research in Information Technology". Communication, Orientation and Socio-Educational Intervention in Educational Research". Since 1997, has published several books, magazines and conferences related to education, technology for learning, social development and interculturality. Lines of research: Educational Guidance, Career Guidance, Evaluative Research, Program Design, Development and Evaluation, Media and ICT Education, Drug Dependency Prevention 	<ul style="list-style-type: none"> Doctorate in Psychopedagogy from the University of Huelva (2000) 	<ul style="list-style-type: none"> Doctorate in Education with a Specialty in Research 	<ul style="list-style-type: none"> DO008 - Thesis Proposal DO009 - Thesis Development DO010 - Thesis Dissertation 	
				Academic Load	3
				Number of Subjects	1
Dr. Julio Martínez	<ul style="list-style-type: none"> Degree in Electrical Mechanical Engineering. Faculty of Engineering, National Autonomous University of Mexico (1992-1996). Master's Degree in Mechanical Engineering. Division of Postgraduate Studies, Faculty of Engineering, National Autonomous University of Mexico (1996-2001). Professor and researcher at the Faculty of Engineering, Autonomous University of Campeche, Campeche Camp. & Universidad Mundo Maya Campus Campeche, Campeche Camp (2001- present). Creator of projects and publications related to Energy and Technology. Has collaborated in conferences and presentations on Engineering, Energy, Sustainable Development, among others since 2006. 	<ul style="list-style-type: none"> Doctorates in Mechanical Engineering. Division of Postgraduate Studies, Faculty of Engineering, National Autonomous University of Mexico (2005). 	<ul style="list-style-type: none"> Master in Strategic Management with a Specialty in Management Master in Strategic Management with a Specialty in Telecommunications Master in Strategic Management with a Specialty in Information Technology 	<ul style="list-style-type: none"> DO008 - Thesis Proposal DO009 - Thesis Development DO010 - Thesis Dissertation DD013 - Logistics Master's Thesis 	
				Academic Load	5
				Number of Subjects	3
Dr. Kamil Giglio	<ul style="list-style-type: none"> Master in Engineering and Knowledge Management, Universidade Federal de Santa Catarina (2010). Graduated in Social Communication, Universidade do Sul de Santa Catarina (2005). Graduate in literature - French, Universidade Federal de Santa Catarina (2005). Professor at the School of Technology Aerotd. Researcher at Wiesbaden Business School. 	<ul style="list-style-type: none"> Doctorate in Engineering and Knowledge Management, Universidade Federal de Santa Catarina (2014) 	<ul style="list-style-type: none"> Master in Education 	<ul style="list-style-type: none"> FP101 - Learning Theories and Methodological Approaches in Education FP087 - Learning Factors FP076 - Collaborative Work in Virtual Environments Master's Thesis 	
				Academic Load	4
				Number of Subjects	4

MAIN PROFESSORS				
Professor	CV Summary	Doctorate	Program	Courses Taught
Dr. Kilian Tutusaus	<ul style="list-style-type: none"> Bachelor's in Marine Sciences from the University of Las Palmas de Gran Canaria (1999-2000). Master's degree in Environmental Engineering from the Chemical Institute of Sarriá (2000-2001). Professor in the face-to-face training program for university professors: Promotion of teaching innovation experiences supported by information and communication technologies. Bolivia (2004-2005). Speaker at the International Internet Global Congress: An example of recycling virtual educational tools, Barcelona (2004). Has been a speaker at various congresses, seminars and conferences on topics related to teaching innovation, the use of ICT in education and technopedagogical models of teaching and learning. Has publications such as: Marine Pollution, Management of Natural Spaces, Oceanography and Marine Resources, Natural Resources, Teaching Experience at Distance in Latin America. 	<ul style="list-style-type: none"> Doctor in Engineering Projects: Environment, Quality, Safety and Communication in Polytechnic University of Catalonia. (2016) 	<ul style="list-style-type: none"> Master in Environmental Management and Auditing 	<ul style="list-style-type: none"> MA106 - Water Circulation MA108 - Fishery Exploitation MA109 - Marine Culture MA110 - Navigation and Marine Transportation MA111 - Mineral and Energy Resources MA136 - Marine Aquaculture Technology: Toward a Sustainable Aquaculture MA137 - Biological Pollution Management MA139 - Management of Natural Marine Protected Areas MA140 - Fisheries Management MA243 - Management of Water Pollutants
				Academic Load
				10
				Number of Subjects
10				
Dr. Laura Pérez	<ul style="list-style-type: none"> Master's in Cognitive and Language Sciences from the Universitat de Barcelona (Spain). Psychologist, specialization in Clinical and Organizational Psychology Pontificia Universidad Javeriana (Bogotá). Psychologist and coach, Florecimiento Humano (<i>Human Flourishing</i>). Experience as researcher at the Universitat de Barcelona, Spain. Experience as a psychologist in the hospitals San Juan de Dios and La Inmaculada, Colombia. Experience in Recruitment and Selection processes for various companies in Spain and the United Kingdom. 	<ul style="list-style-type: none"> Doctorate in Cognitive and Language Sciences from the Universitat de Barcelona (Spain). (2013) 	<ul style="list-style-type: none"> Master in Strategic Management with a Specialty in Management Master in Strategic Management with a Specialty in Telecommunications Master in Strategic Management with a Specialty in Information Technology Master in Physical Activity: Sports Training and Management 	<ul style="list-style-type: none"> DD022 - Organizational Structure and Change DD024 - Organizational Culture and Setting DD031 - Recruitment, Selection and Promotion DD032 - Performance Evaluation and Management by Competencies DD034 - Training and Career Plans DD091/DD092 - Conflict Theory DD107 - Online Dispute Resolution (ODR) FP092- Methodology of Scientific Research Master's Thesis
				Academic Load
				9
				Number of Subjects
9				
Dr. Lázaro Salomón Dibut Toledo	<ul style="list-style-type: none"> Master in Education. University of Cienfuegos, Cuba. Director of Research, Graduate Studies and Continuing Education. University of the Gulf of California, Cabo San Lucas, Baja California Sur, Mexico. Director of Research and Graduate Studies, Universidad de las Californias Internacional, Tijuana, Mexico. Has been a guest professor at various universities in Mexico and Colombia. 	<ul style="list-style-type: none"> Doctor in Pedagogy from the University of Oviedo, Spain. Program: Curriculum Design and Evaluation. (2001) 	<ul style="list-style-type: none"> Doctorate in Projects with a Specialty in Research 	<ul style="list-style-type: none"> DO008 - Thesis Proposal DO009 - Thesis Development DO010 - Thesis Dissertation
				Academic Load
				3
				Number of Subjects
1				

MAIN PROFESSORS				
Professor	CV Summary	Doctorate	Program	Courses Taught
Dr. Leonardo Ribeiro	<ul style="list-style-type: none"> Graduated in Agronomy from Universidade Federal de Viçosa, UFV, Brazil (2000) Environmental Analyst of the Brazilian Institute of Environment and Renewable Natural Resources Has experience in the areas of Environmental Management and Environmental Sociology, mainly performing in processes of environmental licensing of large companies, evaluation of environmental impacts, evaluation of cumulative impacts with the Theory of Ecological Modernization. 	<ul style="list-style-type: none"> Doctor in Environment and Society from the Universidade Estadual de Campinas, UNICAMP, Brazil (2013) 	<ul style="list-style-type: none"> Master in Education Master in Environmental Management and Auditing 	<ul style="list-style-type: none"> FP084 – Environmental Education in Formal Education MA099 - Dynamic Earth MA100 - Coastline and Marine Erosion MA101 - Marine Sediments and Glacial Influence of the Seas MA102 - Basic Marine Ecology MA103 - Marine Culture MA104 - Marine Communities MA105 - Sea Water MA107 - Sea Water Chemistry Master's Thesis
				Academic Load
				10
				Number of Subjects
10				
Dr. Lilian Stevens	<ul style="list-style-type: none"> Bachelor's in General Psychology. Universidad de Oriente. Santiago de Cuba. Cuba (1996). Consultant and teacher/professional training at Universidad Gregório Semedo. Luanda. Angola (2014-2016) Research Project Coordinator and Pedagogical Director, Gregório Semedo University, Luanda, Angola (2011-2013) Was vice-dean of the Faculty of Social Sciences, University of Oriente, Cuba (2005-2006). 	<ul style="list-style-type: none"> Doctor in Pedagogical Sciences, Cátedra Manuel. F. Grant. Universidad de Oriente. Santiago de Cuba (2007) 	<ul style="list-style-type: none"> Master in Strategic Management with a Specialty in Management Master in Education Doctorate in Education with a Specialty in Research 	<ul style="list-style-type: none"> FP118 - Curricular Design and Programming FP124 - Applied Didactics Master's Thesis
				Academic Load
				3
				Number of Subjects
3				
Dr. Lizbeth Salgado Beltran	<ul style="list-style-type: none"> Has taught courses on environment and marketing, market research and consumer behavior at UNISON, ITESM Sonora Norte Campus and UST (Chile). Publications in University and Science Magazines, Fuzzy Economic Review, <i>Agroalimentaria</i>, WOBI, International Journal of Management Science and Information Technology, British Food Journal, <i>Interciencia</i>, etc. 	<ul style="list-style-type: none"> Business Studies, University of Barcelona, Spain (2009) 	<ul style="list-style-type: none"> Doctorate in Projects with a Specialty in Research 	<ul style="list-style-type: none"> DO008 - Thesis Proposal DO009 - Thesis Development DO010 - Thesis Dissertation
				Academic Load
				3
				Number of Subjects
1				
Dr. Luis Acuña	<ul style="list-style-type: none"> Research professor at the Autonomous Universities of Chiapas and Querétaro (Mexico). Member of the National System of Researchers (2018). Member of the Mexican Council of Educational Research (COMIE, Spanish acronym) A.C.; active member of the Latin American Network of Epistemological Studies in Educational Policy (Argentina-Brazil), as well as the Working Group of the Latin American Council of Social Sciences (CLACSO, Spanish acronym) Educational Reforms and Counter-Reforms in Our America. 	<ul style="list-style-type: none"> Doctorate in Regional Studies. Autonomous University of Chiapas (2017) 	<ul style="list-style-type: none"> Doctorate in Education with a Specialty in Research 	<ul style="list-style-type: none"> DO008 - Thesis Proposal DO009 - Thesis Development DO010 - Thesis Dissertation
				Academic Load
				3
				Number of Subjects
1				

MAIN PROFESSORS					
Professor	CV Summary	Doctorate	Program	Courses Taught	
Dr. Luis Dzul	<ul style="list-style-type: none"> • Doctorate in Project Engineering: environment, safety, quality and communication, Polytechnic University of Catalonia, Spain (2009). • Graduate in Project Engineering, Polytechnic University of Catalonia, Spain (2007). • Graduate in Effective Teaching, University of Mayab, Mexico (2004). • Master's Degree in Engineering, National Autonomous University of Mexico, Mexico (2002). • Civil Engineering, Autonomous University of Campeche, Mexico (1999). • Course "Training for Teachers" - FUNIBER (2015). • Professor at the Instituto Tecnológico y de Estudios Superiores de Monterrey (ITESM), Tampico campus, in the subjects "Project Engineering" and "Concrete Structures". Team Teaching Modality (2010 - present) • Researcher at the Center for Industrial Research and Technology of Cantabria (CITICAN) of the European University of the Atlantic. (2014-Present). • Research Professor at the Autonomous University of Campeche (UAC), Mexico. Department of Environmental Microbiology and Biotechnology. Project Engineering Area. (2011-2014). • Member of the Project Engineering Research Group: Design, Sustainability and Communication (GIIP) of the Department of Projects of the Higher School of Industrial Engineering of Barcelona, UPC. (2008-2011). • Guest professor at the Latin University of Panama (Panama campus) at the Postgraduate Studies Center, teaching the subject "International Standards for Project Management". (2011-Present). 	<ul style="list-style-type: none"> • Dr. in Project Engineering at the Polytechnic University of Catalonia (Spain). (2009) 	<ul style="list-style-type: none"> • Master in Strategic Management with a Specialty in Management • Master in Strategic Management with a Specialty in Telecommunications • Master in Strategic Management with a Specialty in Information Technology • Master in Project Design, Administration and Management • Master in Project Design, Administration and Management with a Specialty in Architecture and Urban Planning • Master in Project Design, Administration and Management with a Specialty in Innovation and Product 	<ul style="list-style-type: none"> • IP9002 - Advantages and Difficulties of The Integration of Systems, Grades, Modes and Integration System Models • IP9003 - Integration of Management Systems Based on Standards and Processes • IP9004 - Implementation of the Integrated Management System-practical cases • PC002 - Collaboration and Development Theory • PC012 - International Collaboration System • PC013 - Logical Framework • Master's Thesis 	
				Academic Load	7
				Number of Subjects	7
Dr. Majid Safadaran	<ul style="list-style-type: none"> • Master's degree in TESOL/ESL from the University of New York (U.S.). • Master's degree in Education from the University of Piura (Peru). • Master's degree in TEFL from the University of Piura (Peru). • Master's degree in Accounting from the University of Kerela (India). • Bachelor's in Accounting from the University of Poona (India). 	<ul style="list-style-type: none"> • Doctorate in Education from the Atlantic University (U.S.) (2009) 	<ul style="list-style-type: none"> • Master in Teaching English as a Foreign Language 	<ul style="list-style-type: none"> • FP001 - Approaches to Language • FP005 - Teaching Pronunciation • FP012 - Assessment & Testing in the Classroom • FP013 - English in the Community • Master Thesis 	
				Academic Load	5
				Number of Subjects	5
Dr. Manuel Antonio Masías Vergara	<ul style="list-style-type: none"> • Industrial and Systems Engineer from the University of Piura. Master's degree in Strategic Management in Information Technology from the University of León. • Online tutor for subjects related to Programming and ICT. Specialist in Management and development of system projects, Management of research teams. 	<ul style="list-style-type: none"> • Doctor in Project Engineering from the Universidad Internacional Iberoamericana Universidad Internacional Iberoamericana. (2018) 	<ul style="list-style-type: none"> • Master in Strategic Management with a Specialty in Management • Master in Strategic Management with a Specialty in Information Technology • Master in Strategic Management with a Specialty in Telecommunications • Doctorate in Projects with a Specialty in Research 	<ul style="list-style-type: none"> • DO008 - Thesis Proposal • DO009 - Thesis Development • DO010 - Thesis Dissertation • TI017 - Integration of Business Management Systems • TI020 - e-Business Project Management • TI034 - Languages and Programming Paradigms 	
				Academic Load	9
				Number of Subjects	7

MAIN PROFESSORS				
Professor	CV Summary	Doctorate	Program	Courses Taught
Dr. Manuel Pérez	<ul style="list-style-type: none"> Bachelor's in Psychology, Degree in Pedagogy and Teaching. Has studied Social Education. Master's Degree in Policies and Practices of Educational Innovation for the Knowledge Society. Doctor in Education Sciences, with the qualification of Outstanding Cum Laude. Has worked as a professor in different centers in the province of Malaga. Has worked for ten years as a guidance counselor and head of the guidance department in different HEIs in the province of Malaga and another seven years as a school counselor in the EOE Malaga East, five of them as a coordinator. Head of the Guidance Department in the Instituto Jardín de Málaga. Member of the Malaga's Association of Counselors (AOSMA, Spanish acronym), of which he has been a president of. Has given courses, seminars, talks, written articles and participated in congresses. Member of the Research Group of the University of Málaga HUM 365: "Training, Guidance, Employability, Entrepreneurship, Inclusion and Innovation" 	<ul style="list-style-type: none"> Doctorate in Educational Policy. University of Málaga (2017) 	<ul style="list-style-type: none"> Doctorate in Education with a Specialty in Research 	<ul style="list-style-type: none"> DD008 - Thesis Proposal DD009 - Thesis Development DD010 - Thesis Dissertation
				Academic Load
				3
				Number of Subjects
1				
Dr. Marco Rojo	<ul style="list-style-type: none"> Bachelor in Economy by the Autonomous Metropolitan University (UAM, Mexico). Professor and Doctor in Social Studies (Soc. Economy). Winner of the University Merit Medal. Winner of the Small Research Grand Program (UCLA, USA). Winner of the Public State Management Award (Campeche, Mexico). Specialist in innovation systems, technological change, efficiency and competitiveness. Is currently an researcher for UNINI, Mexico. 	<ul style="list-style-type: none"> Doctorate in Social Studies (Soc. Studies, Post-graduate in Social Studies. Autonomous Metropolitan University (UAM) (2013) 	<ul style="list-style-type: none"> Master in Strategic Management with a Specialty in Management Master in Strategic Management with a Specialty in Telecommunications Master in Strategic Management with a Specialty in Information Technology Doctorate in Projects with a Specialty in Research 	<ul style="list-style-type: none"> DD012 - Management and Operational Direction DD120 - Financial Mathematics DD152 - Economy DD168 - Distribution Management Policies DD171 - Control and Marketing Plan DD1004 - Health Economics DD008 - Thesis Proposal DD009 - Thesis Development DD010 - Thesis Dissertation Master's Thesis
				Academic Load
				10
				Number of Subjects
8				
Dr. Margarita Alcaide Risoto	<ul style="list-style-type: none"> Currently working as a Professor and Practicum Coordinator. Focused on Teaching in Education Lines of research: New technologies applied to guidance and mentoring, intercultural education, guidance in the different non-university stages of the educational system, guidance in the university, citizenship, culture of peace and conflict resolution and diagnosis and intervention in social contexts. 	<ul style="list-style-type: none"> Doctorate in Psychopedagogy, University of Jaén, Spain. (2008) 	<ul style="list-style-type: none"> Doctorate in Education with a Specialty in Research 	<ul style="list-style-type: none"> DD008 - Thesis Proposal DD009 - Thesis Development DD010 - Thesis Dissertation
				Academic Load
				3
				Number of Subjects
1				

MAIN PROFESSORS					
Professor	CV Summary	Doctorate	Program	Courses Taught	
Dr. María Araceli Alonso	<ul style="list-style-type: none"> Diploma of Advanced Studies, IULA – Universitat Pompeu Fabra (Barcelona). (September 2003) Master in Applied Linguistics, IULA - Universitat Pompeu Fabra (Barcelona). (September 2003) A.T.E.R (Attaché Temporaire d'Enseignement et de Recherche), Département d'espagnol et d'études ibéro-américaines, Faculté de Lettres, Langues, Sciences Humaines et Sociales, Université de Bretagne-Sud (France). (2014 – 2016) A.T.E.R (Attaché Temporaire d'Enseignement et de Recherche), Département d'espagnol et d'études ibéro-américaines, Faculté de Lettres, Langues, Sciences Humaines et Sociales, Université de Bretagne-Sud (France). (2012-2014) Collaborating Professor, National University of Distance Education - UNED (Madrid). (2009-2013) Associated Professor, Facultat de Formació del Professorat, Departament de Didàctica de la Llengua i la Literatura at the Universitat de Barcelona (Barcelona). (2009-2010) Associate Professor, Facultat de Traducció e Interpretació, Departament de Traducció i Ciències del Llenguatge at the Universitat Pompeu Fabra (Barcelona) (2006–2010) 	<ul style="list-style-type: none"> Doctor in Applied Linguistics, IULA - Universitat Pompeu Fabra. Barcelona, Spain. (2010) 	<ul style="list-style-type: none"> Master in Teaching Spanish as a Foreign Language Master in Teaching English as a Foreign Language 	<ul style="list-style-type: none"> FP003 - Second language acquisition FP006 – Methodological Approaches: FP014 - Learning Strategies Master's Thesis 	
				Academic Load	4
				Number of Subjects	4
Dr. María Jesús Colmenero Ruíz	<ul style="list-style-type: none"> Accredited teacher (ANECA). Internship (Aula-Problemas). Teaching subjects and direction of doctoral theses at the University of Jaén. Participation in teaching innovation projects. Participation in numerous R&D projects financed in competitive calls of Administrations or public and private entities. 	<ul style="list-style-type: none"> Doctorate in Psychopedagogy , University of Jaen (2005) 	<ul style="list-style-type: none"> Doctorate in Education with a Specialty in Research 	<ul style="list-style-type: none"> DO008 - Thesis Proposal DO009 - Thesis Development DO010 - Thesis Dissertation FP122 - Fundamentals of Special Education: Processes of Attention to Diversity 	
				Academic Load	4
				Number of Subjects	2
Dr. María Luisa Sámano	<ul style="list-style-type: none"> Master in Sciences: Specialization in Chemical Engineering University of the Americas, Puebla (Mexico, 2005). Degree in Chemical Engineering University of the Americas, Puebla (Mexico, 2001). Laboratory Professor, University of the Americas - Puebla. San Andres Cholula, Mexico (2002-2005). Project Coordinator and Water Quality Research, Number Systems, etc. Full-time researcher at the Institute of Environmental Hydraulics of Cantabria, Cantabria University (2010-2014). Author and co-author of scientific articles and book chapters in the field of environmental study. 	<ul style="list-style-type: none"> Doctorate in Environmental Hydraulic University of Cantabria (Spain). (2011) 	<ul style="list-style-type: none"> Master in Environmental Management and Auditing Doctorate in Projects with a Specialty in Research 	<ul style="list-style-type: none"> MA003 - Water Treatment MA015 - Introduction to Project Management: MA016 - The Water Cycle MA017 - Water Management MA018 - Water Analysis and Characterization MA021 - Water and Environmental Education DO008 - Thesis Proposal DO009 - Thesis Development DO010 - Thesis Dissertation Master's Thesis 	
				Academic Load	10
				Number of Subjects	8
Dr. María T. Antúnez de Mayolo L.	<ul style="list-style-type: none"> Master's Degree in School Psychology. Inter-American University of Puerto Rico, San Germán Campus (2003 - 2006). Master in Education; Irregular Behavior, Lima-Peru Universidad Fem. del Sagrado Corazón (1986-1989). Postgraduate degree in Clinical Neuropsychology Lima- Peru, Universidad Federico Villarreal (1987). Bachelor's Degree in Special Education, Lima-Peru Universidad Fem. del Sagrado Corazón. Computer skills: Word, Excel, SPSS, Web, PowerPoint, Publisher, etc. (1979-1983). 	<ul style="list-style-type: none"> Doctor of Curriculum and Learning. Interamerican University of Puerto Rico, San Germán Campus (2016). Doctorates in School Psychology. Interamerican University of Puerto Rico, San Germán Campus (2010). 	<ul style="list-style-type: none"> Doctorate in Education with a Specialty in Research 	<ul style="list-style-type: none"> DO008 - Thesis Proposal DO009 - Thesis Development DO010 - Thesis Dissertation 	
				Academic Load	3
				Number of Subjects	1

MAIN PROFESSORS					
Professor	CV Summary	Doctorate	Program	Courses Taught	
Dr. María Angeles Diaz	<ul style="list-style-type: none"> Professor in the following areas: Education for peace and improvement of coexistence Intercultural, social and citizenship skills Site evaluation High School Counselor 	<ul style="list-style-type: none"> Doctorate in Psychopedagogy, University of Jaén, Spain. (2010) 	<ul style="list-style-type: none"> Doctorate in Education with a Specialty in Research 	<ul style="list-style-type: none"> DO008 - Thesis Proposal DO009 - Thesis Development DO010 - Thesis Dissertation 	
				Academic Load	3
				Number of Subjects	1
Dr. M ^a Luisa Grande	<ul style="list-style-type: none"> Bachelor's Degree in Political Science and Sociology. University of Granada. (1997). Graduate in Nursing. University of Granada (1983). Head Professor from the Faculty of Political Sciences and Sociology. University of Jaén. Participated in several research projects and R&D projects for International Public Administrations and private companies. Publication of several articles and papers on immigration, gender, development cooperation, etc. 	<ul style="list-style-type: none"> Doctorate in Public Law and Special Private Law (2007) 	<ul style="list-style-type: none"> Doctorate in Education with a Specialty in Research 	<ul style="list-style-type: none"> DO008 - Thesis Proposal DO009 - Thesis Development DO010 - Thesis Dissertation 	
				Academic Load	3
				Number of Subjects	1
Dr. Mariacarla Martí González	<ul style="list-style-type: none"> Master's in Education, University of the Arts, Cuba (2009) Degree in Pedagogy and Psychology of Art, University of the Arts (2008) Bachelor's in Psychology, University of Havana (2005) Professor in undergraduate and postgraduate university education in psychology and related areas. Has carried out more than 40 postgraduate training actions that include subjects from her area of knowledge, as well as professional competences for teaching in the classroom and virtual modality. 	<ul style="list-style-type: none"> Doctor in Educational from the University of Saragossa, Spain (2019). 	<ul style="list-style-type: none"> Master in Strategic Management with a Specialty in Management 	<ul style="list-style-type: none"> DD039 - Interpersonal Communication Technique DD041 - Work Team Management Techniques DD042 - Time Management and Conducting Meetings DD045 - Emotional Intelligence IP064 - Training and Communication IP071 - Applied Psychology IP073 - Ergonomics and Applied Psychology Master's Thesis 	
				Academic Load	8
				Number of Subjects	8
Dr. Mário Marques Durão	<ul style="list-style-type: none"> Master's Degree in Education - Personal and Social Training, Institute of Education of the University of Lisbon (2012). Specialized professor of education and teacher in different institutions. External evaluator at Agência de Avaliação e Acreditação do Ensino Superior, Lisbon. 	<ul style="list-style-type: none"> Doctorate in Education - Educational Psychology, University of Lisbon (2017) 	<ul style="list-style-type: none"> Master in Education 	<ul style="list-style-type: none"> FP079- Tutoring Action in the Education System FP110 - Training in Virtual Learning Environments Master's Thesis 	
				Academic Load	3
				Number of Subjects	3
Dr. Martín Tamayo	<ul style="list-style-type: none"> Master in Pedagogy, Universidad Pedagógica Nacional, Mexico (2000) Degree in Sociology of Education, Universidad Pedagógica Nacional, Mexico (1992) Professor at the Universidad Pedagógica Nacional, Mexico (2002-2016) Professor of Humanities, Universidad Interamericana para el Desarrollo, Mexico (2012-2016) Professor at the Universidad Hispanoamericana Justo Sierra, Mexico (2016-2017) 	<ul style="list-style-type: none"> D. in Humanistic Education, Instituto Humanista de Estudios Superiores, Mexico (2011) 	<ul style="list-style-type: none"> Master in Education Doctorate in Education with a Specialty in Research 	<ul style="list-style-type: none"> FP109 - ICT in Education and Learning Theories FP111 - Analysis of Technological Resources and Design of Creative Activities DO008 - Thesis Proposal DO009 - Thesis Development DO010 - Thesis Dissertation 	
				Academic Load	5
				Number of Subjects	3

MAIN PROFESSORS				
Professor	CV Summary	Doctorate	Program	Courses Taught
Dr. Matías Mazzetto	<ul style="list-style-type: none"> • Doctorate in Project Management. UNINI Mexico (2018). • Master's in Project Design, Administration and Management. Miguel de Cervantes European University, Spain (2013). • Occupational Engineer. National Technological University, Argentina (2014). • Information Systems Engineer. Catholic University La Plata, Argentina (2011). • Trainer. Judicial Branch of the Province of Buenos Aires (2010). 	<ul style="list-style-type: none"> • Doctorate in Projects, UNINI Mexico, Mexico (2018) 	<ul style="list-style-type: none"> • Doctorate in Projects with a Specialty in Research 	<ul style="list-style-type: none"> • DD072 - Computing Tools for Project Management • DD074 - Project Evaluation • DD235 - Introduction to the Project Design: from the Conflict to the Problem. • DD236 - Systems Design - Project Solutions • DD237 - Desired Service and Conditions for Provision • DD238 - System Solution: Functional Analysis in the Project • DD239 - Roles of People in the Project • DD240 - Reliability in the Project • DD241 - Environmental Viability of the Project • DD242 - The Project Proposal: Specifications • DD243 - Project Draft and its Presentation
				Academic Load
				11
				Number of Subjects
				3
Dr. Maydali Engracia del Carmen Villasmil	<ul style="list-style-type: none"> • Master in Open and Distance Education (2020) • E-Commerce Expert, FATLA (2019) • E-Learning Platform Expert, FATLA (2018) • Expert in Educational Technology, FATLA (2017) • International Master's Degree in Social Education and Interculturality, Institute of Global Studies (2015) • Magister Scientiarum in Educational Management, Universidad Yacambú (2012) • Degree in Education in Foreign Languages, mention in English, Universidad Nacional Experimental Francisco Miranda (2005) 	<ul style="list-style-type: none"> • Doctor in Education from the Universidad Pedagógica Experimental Libertador (2016) 	<ul style="list-style-type: none"> • Master in Education 	<ul style="list-style-type: none"> • Master's Thesis
				Academic Load
				1
				Number of Subjects
				1
Dr. Mayra González	<ul style="list-style-type: none"> • Master in Counseling and Guidance, Interamerican University of Puerto Rico, Arecibo Campus (2003) • Bachelor's in Social Sciences with a major in Political Sciences from the University of Puerto Rico, Rio Piedras Campus (1996). • Licensed professional counselor, part-time, Universidad Internacional Iberoamericana (2014 to present). • Licensed Professional Counselor and Director of Prevention and Violence against Women, University of Puerto Rico, Utuado (2012) 	<ul style="list-style-type: none"> • Doctorate in Education with a specialization in Guidance and Counseling, Interamerican University of Puerto Rico, Metropolitan, Cupey, P.R. (2017) 	<ul style="list-style-type: none"> • Master in Strategic Management with a Specialty in Management • Master in Strategic Management with a Specialty in Telecommunications • Master in Strategic Management with a Specialty in Information Technology • Master in Project Design, Administration and Management • Master in Project Design, Administration and Management with a Specialty in Architecture and Urban Planning • Master in Project Design, Administration and Management with a Specialty in Innovation and Product 	<ul style="list-style-type: none"> • DD040 - Negotiation and Conflict Resolution Techniques • DD043 - Stress and Burnout • DD044 - Public Speaking Techniques • DD097/DD098 - Mediation. • DD103 - Conflict Resolution/ Transformation in the Organization • DD138 - Conflict Resolution/ Transformation Principles and Processes
				Academic Load
				6
				Number of Subjects
				6

MAIN PROFESSORS					
Professor	CV Summary	Doctorate	Program	Courses Taught	
Dr. Michele Borges	<ul style="list-style-type: none"> • Master in Engineering and Knowledge Management, Federal University of Santa Catarina (2012). • Service Provider in Ayrton Senna Institute. • Individual micro-seller at Inovedu Soluções Educacionais Inovadoras. • Publication of articles, books and book chapters. 	<ul style="list-style-type: none"> • Doctorate in Engineering and Knowledge Management, Federal University of Santa Catarina, Brazil. (2017) 	<ul style="list-style-type: none"> • Master in Education • Doctorate in Education with a Specialty in Research 	<ul style="list-style-type: none"> • FP077- ICT in the Classroom. Educational Applications and Use of Resources • FP090 - Learning Evaluation • FP106 - Curricular Design, Programming and Outcome Development • FP107 - Classroom learning methodologies • FP113 - e-Business and its Integrations in the Corporative Systems for the Educational Management • FP121 - Skills Development • FP182 - Knowledge Management and Innovation within Education • DO008 - Thesis Proposal • DO009 - Thesis Development • DO010 - Thesis Dissertation • Master's Thesis 	
				Academic Load	10
				Number of Subjects	8
Doctor Miguel Ángel Torres Díaz	<ul style="list-style-type: none"> • Doctoral Research: Luis Muñoz Marín as a creator of "Operation. • Serenity" as an Educational Philosophy Project and Sociological Plan for the Puerto Rican Society of the Future. • Doctorate in Sociology, Faculty of Political and Social Sciences, National Autonomous University of Mexico (1974-1977). • Master's Degree in Public Administration from the Graduate School of Public Administration, University of Puerto Rico, Río Piedras Campus Thesis: "El Desahorro en Puerto Rico 1968 al 1972" (1970-1974). • Bachelor's Degree in Social Sciences achieving two major specialties: Economics and Sociology at the School of Social Sciences, University of Puerto Rico, Río Piedras Campus (1966-1970). 	<ul style="list-style-type: none"> • Doctorate in History: Emphasis on Sociology, Economics, Education and Politics in the historical context of social crises and globalization. Center for Advanced Studies of Puerto Rico and the Caribbean, San Juan, Puerto Rico. (2015) 	<ul style="list-style-type: none"> • Doctorate in Education with a Specialty in Research 	<ul style="list-style-type: none"> • DO008 - Thesis Proposal • DO009 - Thesis Development • DO010 - Thesis Dissertation 	
				Academic Load	3
				Number of Subjects	1
Dr. Millie Perez	<ul style="list-style-type: none"> • Master's in Education (Special Needs), University of Central Bayamon (2007). • Master's in Education (Educational Technology and Instructional Systems), University of Sagrado Corazon (2006). • Bachelor's in Secondary Education from the University of Puerto Rico (1997) • University education with a specialization in occupational education, distance education and technology. • Has taught courses at the university level, training teachers, and advising government and university agencies. Certified in the Moodle platform and Blackboard. 	<ul style="list-style-type: none"> • Doctorate in Education (Distance Education) from Nova Southern University, Florida, USA (2016) 	<ul style="list-style-type: none"> • Doctorate in Education with a Specialty in Research 	<ul style="list-style-type: none"> • DO008 - Thesis Proposal • DO009 - Thesis Development • DO010 - Thesis Dissertation 	
				Academic Load	3
				Number of Subjects	1

MAIN PROFESSORS				
Professor	CV Summary	Doctorate	Program	Courses Taught
Dr. Mirtha Silvana Marín Garat	<ul style="list-style-type: none"> Master's Degree in Sustainable Development, University of Lanus – Foro Latino Americano Foro de Ciencias Ambientales Latin American Forum for Environmental Sciences Forum (FLCAM)- UNESCO Chair in Sustainable Development (2004). Consultant for the development of projects for local or foreign companies (especially Brazil) in the Rivera Free Market Zone (April 1995 - March 2000). Consulting in local project development and social and environmental responsibility (design, direction and management). (March 2000). Coordinator of workshops for teachers at the Alberto Chipande Institute of Higher Education (2014) Mozambique. Complementary training: <ul style="list-style-type: none"> Course on "Training for Teachers" - FUNIBER (December 2015). Course "Training for Directors of Thesis" - FUNIBER (December 2015). Course on "Teaching in the virtual field FUNIBER, 175 hours (July 2015). 	<ul style="list-style-type: none"> Doctorate in Projects. Universidad Internacional Iberoamericana (Mexico) (2019) 	<ul style="list-style-type: none"> Master in Project Design, Administration and Management Master in Project Design, Administration and Management with a Specialty in Architecture and Urban Planning Master in Project Design, Administration and Management with a Specialty in Innovation and Product 	<ul style="list-style-type: none"> DD050 - Introduction to Projects DD051 - Project System Design DD052 - Analysis of Provision of Services DD053 - Functional Analysis of the Project DD054 - Project Ergonomics DD055 - Project Security and Reliability DD056 - Environment in a Project DD057 - Project Specifications DD058 - Project Draft Preparation DD070 - Introduction to Project Management DD073 - Project Monitoring and Control
				Academic Load
				11
				Number of Subjects
3				
Dr. Mónica García	<ul style="list-style-type: none"> Bachelor's in Environmental Sciences. Specialty: Environmental Management. University of Leon Doctorate in Physics, Chemistry and Applied Sciences with an outstanding Cum Laude rating. University Jaume I of Castellón Master's Degree in Environmental Impact Assessment from the Ecological Research Institute of Cádiz Pedagogical Aptitude Course (CAP, Spanish acronym). Institute of Education Sciences (ICE, Spanish acronym). Polytechnic University of Valencia Higher Studies in Traditional Chinese Medicine. Higher School of Traditional Chinese Medicine Various courses/training on acupuncture, oriental chiropractic and massage. Center for acupuncture, therapeutic and sports massage, reflexology Professor at the Higher School of MTC (Valencia) 	<ul style="list-style-type: none"> Doctorate in Physics, Chemistry and Applied Sciences with an outstanding Cum Laude rating. University Jaume I of Castellón (2016) 	<ul style="list-style-type: none"> Master in Naturopathic Sciences 	<ul style="list-style-type: none"> MTC007 - Differentiation of Syndromes MTC008 - MTC Therapeutic MTC009 - Auriculartherapy MTC010 - Meridian and Points (Part I) MTC011 - Meridian and Points (Part II) MTC012 - Acupuncture Techniques MTC013 - Acupuncture - Internal Medicine MTC014 - Acupuncture - Specialties MTC025 - Stage Master's Thesis
				Academic Load
				10
				Number of Subjects
10				
Dr. Narciso Miguel Contreras Izquierdo	<ul style="list-style-type: none"> University expert in Teaching Spanish as a Foreign Language by the Menéndez Pelayo International University (Spain). Bachelor's degree in Philosophy and Literature (Philology) from the University of Jaen (Spain). TEACHING <ul style="list-style-type: none"> Doctoral assistant professor in the Spanish Philology Department at the University of Jaén (Spain). Director of the Secretariat of International Mobility Programs from the University of Jaén (Spain). Distance Master's Degree Professor in Applied Linguistics to the Teaching of Spanish as a Foreign Language at the University of Jaen. Speaker in various congresses and conferences related to Spanish methodology, lexicon and its varieties in LLEE didactics. Professor of the Hispanic Department in Attila Jozsef of Szeged University (Hungary) for 3 years. Professor of the Instituto Cervantes in Romania and the University of Bucharest. President of the board of DELE in Hungary and Romania, and Chairman of the Board of Examiners for these tests at the University of Jaen. 	<ul style="list-style-type: none"> Doctorate in Spanish Philology (University of Jaen, Spain). (2003) 	<ul style="list-style-type: none"> Master in Teaching Spanish as a Foreign Language 	<ul style="list-style-type: none"> DO008 - Thesis Proposal DO009 - Thesis Development DO010 - Thesis Dissertation FP025 - Spanish and its Varieties FP026 - Teaching Vocabulary and Pronunciation
				Academic Load
				5
				Number of Subjects
3				

MAIN PROFESSORS					
Professor	CV Summary	Doctorate	Program	Courses Taught	
Dr. Nivia Núñez de la Paz	<ul style="list-style-type: none"> • Postdoctoral degree in Theology Faculdades EST, São Leopoldo, Brasil (2015-2017). • Master in Theology Faculdades EST, São Leopoldo, Brasil (2002-2004). • Specialization. Public Policies and Gender Justice. CLACSO, Argentina (2018-present). • Complementary training in the virtual platform Moodle. • Professional experience as a professor at university and master's level in different institutions. 	<ul style="list-style-type: none"> • Doctorate in Theology, Faculdades EST, São Leopoldo, Brazil (2008) 	<ul style="list-style-type: none"> • Master in Education 	<ul style="list-style-type: none"> • FP078- Interculturality and Education • FP080- Conflict Solution and Transformation in the Educational Environment • FP090 - Learning Evaluation • Master's Thesis 	
				Academic Load	4
				Number of Subjects	4
Dr. Noelia Margarita Moreno Martínez	<ul style="list-style-type: none"> • Diploma of Advanced Studies (DEA) in the Doctoral Program: "Education Professionals facing Social Change" • Certificate in Speech Therapy; Teaching Diploma in the Hearing and Language Specialty. • Bachelor in Pedagogy. • Researcher in the Edulnnovagogía (HUM971) Group in the Universidad Pablo de Olavide (Seville). Former member of the MapEduca Group of the Geography department of the Universidad de Málaga carrying out two Teaching Innovation Projects about Geolocation and digital mapping in Education tools. • Member of a teaching team developing an Educational Innovation Project on Gamification, Augmented Reality and Video Recording. • Specialist in ICT applied to Education: Emerging technologies: Augmented Reality, 3D Modeling, Geolocation, Mobile Learning, Gamification, Educational Robotics, Programming. 	<ul style="list-style-type: none"> • Doctor in Pedagogy from the University of Málaga, Spain (2014). 	<ul style="list-style-type: none"> • Doctorate in Education with a Specialty in Research 	<ul style="list-style-type: none"> • DO008 - Thesis Proposal • DO009 - Thesis Development • DO010 - Thesis Dissertation 	
				Academic Load	3
				Number of Subjects	1
Dr. Oscar Ulloa	<ul style="list-style-type: none"> • Master in Community Development-Social Psychology. Universidad Central de Las Villas, Cuba (2006-2008). • Diploma in Social Work Training, University of Havana, Cuba (2002-2003). • Bachelor's in Psychology. University of Oriente (1997-2002). • Collaborating Professor, Master's Program in Sexology and Society (2015-present). • Fellow (Doctorate), Federal University of Rio Grande do Sul, Brazil, Faculty of Education, Doctorate in Education (2011-2015). • Participated in Research Projects, as of 2005 on Social Sciences, Masculinity, Paternity and Psychology. • Author of some scientific journals and book articles. 	<ul style="list-style-type: none"> • Doctorate in Education, Federal University of Rio Grande do Sul, Brazil (2011-2015). 	<ul style="list-style-type: none"> • Master in Strategic Management with a Specialty in Management • Master in Strategic Management with a Specialty in Telecommunications • Master in Strategic Management with a Specialty in Information Technology • Master in Education • Doctorate in Education with a Specialty in Research 	<ul style="list-style-type: none"> • DD100- Conflict Solution and Transformation in the Educational Environment • DD102 - Resolution/ Transformation of Conflict in the Community • DD105 - Resolution/ Transformation of Conflict in the Health Field • DO008 - Thesis Proposal • DO009 - Thesis Development • DO010 - Thesis Dissertation • FP092- Methodology of Scientific Research • FP117 - Learning Theories and Teaching Methodological Bases • FP119 - Learning Factors • Master's Thesis 	
				Academic Load	10
				Number of Subjects	8
Dr. Pablo Blanco	<ul style="list-style-type: none"> • Degree in Journalism (2011). • Bachelors Degree in Physical Activity and Sports Sciences (2010). • Master in Sports Programs: Management, High Performance and Social Development (2012). • Journalist. • Work experience in the field of management and communication in the field of sports. 	<ul style="list-style-type: none"> • Doctorate in Sciences of Physical Activity and Sport at the University Camilo José Cela (2018). 	<ul style="list-style-type: none"> • Master in Physical Activity: Sports Training and Management 	<ul style="list-style-type: none"> • DP001 - Administration and Management of Sport Entities • DP002 - Strategic Management and Planning of Sport Organizations • DP003 - Sports Marketing. Applications • DP007 - Society of Sport and Information 	
				Academic Load	4
				Number of Subjects	4

MAIN PROFESSORS					
Professor	CV Summary	Doctorate	Program	Courses Taught	
Dr. Paula Arzadun	<ul style="list-style-type: none"> • Master in Cooperative Business Administration • Postgraduate degree in Data Science • Degree in Economics (Universidad de Buenos Aires, Argentina) • Numerous publications related to education, development and cooperativism. 	<ul style="list-style-type: none"> • Doctor in Business Administration (Universidad de Costa Rica) 	<ul style="list-style-type: none"> • Master in Project Design, Administration and Management • Master in Project Design, Administration and Management with a Specialty in Architecture and Urban Planning • Master in Project Design, Administration and Management with a Specialty in Innovation and Product • Doctorate in Projects with a Specialty in Research 	<ul style="list-style-type: none"> • DD070: Introduction to Project Management • TR038: Project Planning and Management 	
				Academic Load	2
				Number of Subjects	2
Dr. Pedro Barros García	<ul style="list-style-type: none"> • Degree in Philosophy and Arts, University of Granada (1969) • More than 45 years of university teaching experience at the University of Granada in subjects related to the Spanish language and Spanish as a foreign language, at undergraduate, postgraduate and doctorate levels • Participation in a large number of seminars and courses related to language teaching • More than 40 years of research experience and participation in numerous research projects • Numerous publications related to L1 and LE language teaching • Direction of 11 doctoral theses • Direction of 20 master's theses 	<ul style="list-style-type: none"> • Doctorate in Romance Philology, University of Granada (1975) 	<ul style="list-style-type: none"> • Doctorate in Education with a Specialty in Research 	<ul style="list-style-type: none"> • DO008 - Thesis Proposal • DO009 - Thesis Development • DO010 - Thesis Dissertation 	
				Academic Load	3
				Number of Subjects	1
Dr. Pedro Latorre Román	<ul style="list-style-type: none"> • Bachelor's in Physical Education, University of Granada (1993). • Specialist Course in Sports Training (UNED, 1999). • Specialist Course in Sports Medicine and Traumatology (University of Almería, 2000). • Direction of 7 doctoral theses 	<ul style="list-style-type: none"> • Doctorate in Physical Activity and Health (outstanding cum laude), University of Granada (2003) 	<ul style="list-style-type: none"> • Doctorate in Education with a Specialty in Research 	<ul style="list-style-type: none"> • DO008 - Thesis Proposal • DO009 - Thesis Development • DO010 - Thesis Dissertation • FP119 - Learning Factors 	
				Academic Load	4
				Number of Subjects	2
Dr. Pereira Alfredo	<ul style="list-style-type: none"> • Master in Environmental Technology and Engineering, University of Leon, Spain (2011) • Post-Graduation in Free Software by the Catholic University of Brasilia (2010) • Professor at the Agostinho Neto Public University, Methodist Private University of Angola and at the Escuela Superior Pedagógica de Bengo in the programs of Bachelor's, Master's in Entrepreneurship and Doctorate in Management. • Professor of subjects in the area of Marketing and Logistics; Information Systems; Computing; Environment and Sustainable Development. • Experience in Bachelor and Doctorate boards. 	<ul style="list-style-type: none"> • Doctorate in Information Sciences, Specialization in Information Systems and Technologies, University of Fernando Pessoa, (2015). 	<ul style="list-style-type: none"> • Doctorate in Projects with a Specialty in Research 	<ul style="list-style-type: none"> • DO008 - Thesis Proposal • DO009 - Thesis Development • DO010 - Thesis Dissertation 	
				Academic Load	3
				Number of Subjects	1

MAIN PROFESSORS				
Professor	CV Summary	Doctorate	Program	Courses Taught
Dr. Priscilla Almeida de Souza	<ul style="list-style-type: none"> Bachelor in Human Nutrition and Dietetics, Centro Universitario Belo Horizonte (UNIBH), Brazil. (2002-2006). Postgraduate in Sport Nutrition, Centro Universitario Belo Horizonte (UNIBH), Brasil. (2006-2008). Diploma of Advanced Studies (DEA) in Physiology. (2009-2012). 	<ul style="list-style-type: none"> Doctor in Biomedicine. University of Zaragoza, Spain. (2016) 	<ul style="list-style-type: none"> Master in Strategic Management with a Specialty in Management Master in Physical Activity: Sports Training and Management Master in Naturopathic Sciences 	<ul style="list-style-type: none"> SN018- Evaluation of the Nutritional State SN042 - Kinanthropometry SN043 - Ergogenic Aids SN047 - Eating Disorders in Sports SN198 - Basic Aspects of Nutrition SN217 -Nutrition and Sport TR023 - Food and Drinks Management Master's Thesis
				Academic Load
				8
				Number of Subjects
8				
Dr. Ramón María Calduch	<ul style="list-style-type: none"> Bachelor's in Law. Open University of Catalonia. Master's in Anthropology of Medicine from Rovira I Virgili University. Vice-President of the European Foundation of Traditional Chinese Medicine (Spain) Vice-President of PEFOTS (Pan European Federation of Chinese Medicine Societies). President of ECCTCM (European Chamber of Commerce for TCM). Chairman of the Supervisory Board of WFCMS (World Federation of Chinese Medicine Societies). Member of the Expert Committee of the "International TCM Program for Cooperation in Science and Technology" appointed by the Ministry of Science and Technology of the P.R. China. Guest Professor in Management at Beijing TCM University. Vice Chairman of the Specialty Committee of Translation of WFCMS Vice Chairman of the Specialty Committee of Standardization of WFCMS Vice-President of the World Federation of Acupuncture and Moxibustion Societies (WFAS) Member of ISO/TC249TCM and member of Chair Advisory Group. International Award for Contribution to Traditional Chinese Medicine, 3rd edition (awarded by WFCMS in November 2009). 	<ul style="list-style-type: none"> Doctor of Law (PhD). Abat Oliba University. (2017) 	<ul style="list-style-type: none"> Master in Naturopathic Sciences 	<ul style="list-style-type: none"> SN028 - History of Biological-Naturist Medicine Master's Thesis
				Academic Load
				2
				Number of Subjects
2				
Dr. Ramón Palí Casanova	<ul style="list-style-type: none"> Bachelor's in Mechanical Engineering from the Technological Institute of Campeche (Mexico). Master's in Physics Applied to Materials by the CINVESTAV IPN Unidad Mérida (Mexico). Author of numerous research publishings and projects. Member of the CONACYT from 2003 to 2006. 	<ul style="list-style-type: none"> Doctor in Materials Engineering and Technology from the Applied Chemistry Research Center (Mexico) (2014) 	<ul style="list-style-type: none"> Master in Environmental Management and Auditing Master in Strategic Management with a Specialty in Management 	<ul style="list-style-type: none"> DD133 - Occupational Risk Prevention: OHSAS 18001 MA039 - Industrial Wastewater Treatment MA057 - Introduction to Renewable Energies MA059 - Solar Thermal Energy MA061 - Hydraulic Energy MA064 - Biomass Energy MA065 - Sea Energy MA092 - Fundamentals of Environmental Engineering MA143 - Energy Recovery MA029 - Facilities and Water Treatment Master's Thesis
				Academic Load
				11
				Number of Subjects
11				

MAIN PROFESSORS					
Professor	CV Summary	Doctorate	Program	Courses Taught	
Dr. René Velázquez	<ul style="list-style-type: none"> Master of Science in Business Planning and Regional Development, Instituto Tecnológico de Mérida (ITM). Mexico. (2004) Electronic Engineering, Instituto Tecnológico de Mérida (ITM). Mexico. (1999) 	<ul style="list-style-type: none"> Doctor in Social Sciences with a Specialization in Regional Studies, El Colegio de la Frontera Norte. Mexico. (2010) 	<ul style="list-style-type: none"> Master in Strategic Management with a Specialty in Management Master in Strategic Management with a Specialty in Telecommunications Master in Strategic Management with a Specialty in Information Technology 	<ul style="list-style-type: none"> DD040 - Negotiation and Conflict Resolution Techniques IP062 - Ergonomics FP092- Methodology of Scientific Research Master's Thesis 	
				Academic Load	4
				Number of Subjects	4
Dr. Ricardo Jorge de Guedes Almeida	<ul style="list-style-type: none"> Master in Biological-Naturist Studies, University of León (2011). Bachelor's Degree in Nursing, Provision of Nursing Care, Escola Superior de Saúde de Viseu - Polytechnic Institute of Viseu, Portugal (2008). 	<ul style="list-style-type: none"> Doctorate in Education, Ibero-American International University of Mexico. (2018) 	<ul style="list-style-type: none"> Master and Certification in Naturopathic Sciences 	<ul style="list-style-type: none"> MN013- Iridology and Sclerology MN014 - Methods of Naturopathic Evaluations MN016 - Homeopathic Therapy in Acute Diseases MN017 - Homeopathic Therapy in Chronic Diseases SN090 - Ozone-therapy SN091- Heliotherapy, Thalassotherapy, Mud Therapy and Aerotherapy SN097- Neural Therapy and Neurofocality SN100 - Hydrology, Mineral-Medicine, Waters and Balneotherapy SN103 - Sophrology SN105 - Spagyria SN136- Electroacupuncture of Voll and Bioresonance Master's Thesis 	
				Academic Load	12
				Number of Subjects	12
Dr. Rita Sierra	<ul style="list-style-type: none"> Degree in Institutional and Curricular Management from the National University of Cuyo (2005). Diploma in Education and New Technologies, Latin American Faculty of Social Sciences (2006). Higher Specialist in Education and New Technologies, Latin American Faculty of Social Sciences (2008). Specialist in Virtual Learning Environments, OIE Virtual Educa Argentina and the Center for Higher University Studies (2012). Teaching experience since 2008 in subjects related to the pedagogical use of ICT in didactic learning applications and virtual learning environments as a learning scenario. 	<ul style="list-style-type: none"> Doctorate in Management and Planning for Educational Quality in the 21st Century Society. University of Jaén. Spain (2011) 	<ul style="list-style-type: none"> Doctorate in Education with a Specialty in Research 	<ul style="list-style-type: none"> DO008 - Thesis Proposal DO009 - Thesis Development DO010 - Thesis Dissertation 	
				Academic Load	3
				Number of Subjects	1
Dr. Roberto Álvarez (Department Director)	<ul style="list-style-type: none"> Architect (FADU-UBA, Argentina). Graduate in Strategic Planning (FADU-UBA, Argentina). Graduate in Project Evaluation for Non-Specialists (FADU-UBA, Argentina). Specialist in Strategic Management for Design. Project Management and Design (UBA- Polit- of Milan, Argentina). 	<ul style="list-style-type: none"> Dr. in Project Engineering at the Polytechnic University of Catalonia (Spain). (2009) 	<ul style="list-style-type: none"> Master in Project Design, Administration and Management Master in Project Design, Administration and Management with a Specialty in Architecture and Urban Planning Master in Project Design, Administration and Management with a Specialty in Innovation and Product 	<ul style="list-style-type: none"> AU004 - Economic, Social, and Institutional Contextual Components of the Project AU006 - Architectural-Urban Project Theory AU010 - Integral Management of Design and Product Master's Thesis 	
				Academic Load	4
				Number of Subjects	4

MAIN PROFESSORS				
Professor	CV Summary	Doctorate	Program	Courses Taught
Dr. Roberto Fabiano Fernandes	<ul style="list-style-type: none"> Master's Degree in Engineering and Knowledge Management, Federal University of Santa Catarina (2010-2012). Specialization in Project and Software Engineering, South University of Santa Catalina (2009). Degree in Computer Science, Blumenau Regional University Foundation (2001). Has experience in the areas of engineering and production with an emphasis on innovation management. Has specifically worked in the following areas: innovation, project management, identification of opportunities, design and knowledge management. Complementary training: <ul style="list-style-type: none"> Course: "Training for Thesis Directors" - FUNIBER (2015) Course: "Training for Teachers" - FUNIBER (2015). 	<ul style="list-style-type: none"> Doctorate in Engineering and Knowledge Management, Federal University of Santa Catarina, USFC, Brazil. (2017) 	<ul style="list-style-type: none"> Master in Strategic Management with a Specialty in Management Master in Strategic Management with a Specialty in Telecommunications Master in Strategic Management with a Specialty in Information Technology 	<ul style="list-style-type: none"> TI030 - Network Security and Management TI034 - Languages and Programming Paradigms TI035 - Architectures, Networks and Distributive Systems TI036 - Web Technology and Engineering TI037 - Integral Design and Analysis of Systems and Requirements TI038 - Data Model and Database Design TI040 - Management of Databases and Information Resources TI041 - Business Software Process Master's Thesis
				Academic Load
				9
				Number of Subjects
9				
Dr. Roberto García	<ul style="list-style-type: none"> Graduated from the University of Valle de Mexico, San Rafael Campus, Mexico City. Master in Constitutional Law and Amparo, at the Law School of the National Bar Association, Mexico Federal District. Has professional experience in the marketing sector. 	<ul style="list-style-type: none"> Doctor of Law at the National Institute of Legal Development, Mexico Federal District. (2011) 	<ul style="list-style-type: none"> Master in Strategic Management with a Specialty in Management 	<ul style="list-style-type: none"> DD090 - Business Ethics and Corporate Social Responsibilities DD161 - Consumer-Buyer Behavior DD165 - Marketing Audits DD166 - Product and Brand Policy Management DD167 - Price Management Policy DD169 - Communication Management Policies
				Academic Load
				5
				Number of Subjects
5				
Dr. Rocio Jimenez	<ul style="list-style-type: none"> Doctoral professor in the Research Methods Area of the University of Seville. Extraordinary Doctorate Award from the University of Seville. Research experience since 2005. Was recently the main researcher in the R&D project (2013-2016), "Las mujeres como tejedoras de las redes sociales: Estrategias relacionales e inclusión digital" <i>"Women as Weavers of Social Networks: Relational Strategies and Digital Inclusion"</i> (Edu2013-45134-P) Financed By The Ministry Of Economy and Competitiveness in the framework of the State Program for the Promotion of Scientific and Technical Research of Excellence (2013-2016 (Spain)). University teaching experience for more than 10 years. 	<ul style="list-style-type: none"> Doctor in Pedagogy: Educational research and interventions, University of Seville (2005) 	<ul style="list-style-type: none"> Doctorate in Education with a Specialty in Research 	<ul style="list-style-type: none"> DO008 - Thesis Proposal DO009 - Thesis Development DO010 - Thesis Dissertation
				Academic Load
				3
				Number of Subjects
1				

MAIN PROFESSORS					
Professor	CV Summary	Doctorate	Program	Courses Taught	
Dr. Rosa Eva Valle	<ul style="list-style-type: none"> • Master in Human Resources Management and Direction. Training Business Center. Chamber of Commerce of León-ESIC Company (1993). • Bachelor's in Philosophy and Education Sciences. Head Professor from the Faculty of Education. University of León (as of 1990). • Deputy Director of the Department of General and Specific Didactics and Theory of Education University of León (as of 2011). • Coordinator of the Master's Degree in Educational Guidance (from 2014). • Participation in several teaching innovation projects and R&D projects financed in competitive calls from Administrations or public and private entities. • Collaboration as a researcher in non-competitive R&D projects with Administrations or public or private entities. 	<ul style="list-style-type: none"> • Doctor of Education in Philosophy and Educational Sciences. National University of Distance Education (2004). 	<ul style="list-style-type: none"> • Doctorate in Education with a Specialty in Research 	<ul style="list-style-type: none"> • DO008 - Thesis Proposal • DO009 - Thesis Development • DO010 - Thesis Dissertation 	
				Academic Load	3
				Number of Subjects	1
Dr. Rubén Calderón	<ul style="list-style-type: none"> • Bachelor's in Economic Sciences from the University of Valladolid (Spain). • Master of Advanced Studies-Research Proficiency: Application of the real options for the demand value in higher education - Applied Economy Department - CCEE Faculty - University of Valladolid. • Pedagogical Aptitude Course (CAP, Spanish acronym). • Senior Technician in Occupational Risk Prevention (Safety at Work). • Higher Technician in Occupational Risk Prevention (Ergonomics and Applied Psychosociology). • Superior Technician in Occupational Risk Prevention (Industrial Hygiene). • For 10 years, has participated in administrative positions at the European University of Miguel de Cervantes. • 6 years of official experience as a professor in 3-year undergraduate and bachelor's degrees teaching subjects related to Economics, Microeconomics, Macroeconomics. • Has 4 scientific publications in Spanish and foreign magazines, books and monographs. • Participates as a communicator and assistant in different professional congresses. • Member of the Spanish Association of Economics of Education. 	<ul style="list-style-type: none"> • Doctorate in Economics from the Universidad Antonio de Nebrija (Spain). (2012) 	<ul style="list-style-type: none"> • Master in Strategic Management with a Specialty in Management 	<ul style="list-style-type: none"> • DD108 - Family Business Concepts and Characteristics • DD109 - Succession and Continuity in Family Business • DD110 - Systematic Focus Applied to Conflict in Family Businesses • DD112 - Governing Structures and Bodies • DD113 - The Family Protocol • DD114 - Property Management in Family Businesses • DD115 - Key Factors for Success in the Family Business 	
				Academic Load	7
				Number of Subjects	7
Dr. Salvador Doblás	<ul style="list-style-type: none"> • Professor in Audiovisual Department Communication and Advertising department. University of Málaga. Málaga. 2009 - Present. • Research visit with mention of European Doctorate School of Communication and Education - School of Health of the University of Algarve - Faro - Portugal. 2011. • Scholarship in the General Management of the Andalusian Institute of Public Administration for the support in Communication and Institutional Image and Marketing. Seville. 2007. • International Association of Researchers Award, Seville, 2007. • Candidate for the Andalusian Healthcare Quality Agency Awards. Seville. 2006. ? Candidate for the Spanish Network of Business University Foundations Awards. Mallorca 2005. • Collaborator in the III Doctoral Conferences of Andalusia. Málaga 2005. • Professor in the Open Training Classroom for the Elderly. University of Málaga. 2004-2005. • Business-University Agreement. 2005. Technological Park of Andalusia. P.T.A. (Spanish acronym). (Spanish acronym). Carlos Haya Regional University Hospital in Malaga. H.R.U.C.H. - University of Málaga U.M.A. • II Andalusian Doctoral Conference Prize, Seville 2004. 	<ul style="list-style-type: none"> • Doctorate in Audiovisual Communication, University of Málaga, Spain (2016) 	<ul style="list-style-type: none"> • Doctorate in Education with a Specialty in Research 	<ul style="list-style-type: none"> • DO008 - Thesis Proposal • DO009 - Thesis Development • DO010 - Thesis Dissertation 	
				Academic Load	3
				Number of Subjects	1

MAIN PROFESSORS				
Professor	CV Summary	Doctorate	Program	Courses Taught
Dr. Sandra Milena Camelo	<ul style="list-style-type: none"> • Master's in Cultural Studies Pontifical Javeriana University (2012). • Master in Linguistics Applied to the Teaching of Spanish as a Foreign Language University of Jaén, Spain. • Bachelor's in Modern Languages Pontifical Javeriana University (2008). 	<ul style="list-style-type: none"> • Doctor in Cultural Studies. Goldsmiths College, London (2012-2017) 	<ul style="list-style-type: none"> • Master in Teaching Spanish as a Foreign Language • Master in Teaching English as a Foreign Language 	<ul style="list-style-type: none"> • FP007 - Classroom Management • FP008 - Developing Language Skills • FP009 - Materials & Resources • FP010 - Computer assisted language learning • Master's Thesis
				Academic Load
				5
				Number of Subjects
5				
Dr. Santos Gracia	<ul style="list-style-type: none"> • Doctor in Multimedia Engineering, Polytechnic University of Catalonia, Spain (2000). • Industrial Engineer, Polytechnic University of Catalonia, Spain (1996). • Course "Training for Teachers" - FUNIBER (2015). • Professor of "Introduction to Project Management" in Doctorate of Integration and Economic Development, University of Leon, Spain (2007-2010). • Professor of "Project Design" in Doctorate in Project Engineering, Technological University of Panama, Panama (2007-2010). • Professor of "Project Design and Management" in Doctorate in Project Engineering: Environment, Quality, Safety and Communication in Polytechnic University of Catalonia, Spain (2003-2009). • Professor of "Virtual Collaborative Work Environments" in Doctorate in Project Engineering: Environment, Quality, Safety and Communication in Polytechnic University of Catalonia, Spain (2003-2009). • Professor of "Project and Communication" in Doctorate in Project Engineering: Environment, Quality, Safety and Communication in Polytechnic University of Catalonia, Spain (2003-2009). • Professor of Project Engineering Degree, Polytechnic University of Catalonia, Spain (2002-2009). 	<ul style="list-style-type: none"> • Doctor in Multimedia Engineering, Polytechnic University of Catalonia, Spain (2000) 	<ul style="list-style-type: none"> • Master in Strategic Management with a Specialty in Management • Master in Strategic Management with a Specialty in Telecommunications • Master in Strategic Management with a Specialty in Information Technology • Master in Project Design, Administration and Management • Master in Project Design, Administration and Management with a Specialty in Architecture and Urban Planning • Master in Project Design, Administration and Management with a Specialty in Innovation and Product • Doctorate in Projects with a Specialty in Research 	<ul style="list-style-type: none"> • Master's Thesis
				Academic Load
				1
				Number of Subjects
1				

MAIN PROFESSORS				
Professor	CV Summary	Doctorate	Program	Courses Taught
Dr. Santiago Brie	<ul style="list-style-type: none"> Master's Degree in Project Design, Administration and Management, University of León, Spain (June 2008-June 2011) Degree in Urban Environmental Management, Department of Productive and Technological Development, National University of Lanus (UNLA) Argentina (March, 2002-December, 2007) Professor of Urban Environmental Management at the National University of Lanus. Project design and implementation of the Geographic Information Systems Laboratory for the degree of Urban Environmental Management, Department of Productivity and Technological Development (July 2011 - December 2011) Complementary training: <ul style="list-style-type: none"> Teacher Training (December 2015). Training for Thesis Directors, (December 2015). Teaching in the virtual field FUNIBER, 175 hours (July 2015) 	<ul style="list-style-type: none"> Doctorate in Projects. Universidad Internacional Iberoamericana (Mexico) (2019) 	<ul style="list-style-type: none"> Master in Project Design, Administration and Management Master in Project Design, Administration and Management with a Specialty in Architecture and Urban Planning Master in Project Design, Administration and Management with a Specialty in Innovation and Product Doctorate in Projects with a Specialty in Research 	<ul style="list-style-type: none"> AU001 - Architecture and Urbanism Interrelation AU002 - The Environment in Urban Planning - Architectural Projects AU005 - City Marketing AU007 - Preservation of the Architectural Urban Heritage AU008 - The Function of the State AU011 - Areas of Design Contextual Conditions and User Requirements AU012 - Innovation as a Tool for Improvement and Product Value Contribution AU013 - Product and the Environment DD070 - Introduction to Project Management DD073 - Project Monitoring and Control PC013 - Logical Framework TR038 - Planning and Management of Projects
				Academic Load
				12
				Number of Subjects
				12
Dr. Sheila Queralt Estévez	<ul style="list-style-type: none"> Master's degree in Forensic Science and Criminal Intelligence. Universitat Autònoma de Barcelona (UAB), 2016. Master's degree in Graphic Design. UAB, 2016. Master's degree in Applied Statistics to Research. Virtual Institute of Human Sciences, Madrid, 2013. Master's Degree in Theoretical and Applied Linguistics. UPF, Barcelona, 2013. Master's in Criminology with a Specialty in Forensic Document Analysis and Judicial Expertise of intellectual and industrial property. Universitat Autònoma de Barcelona, Barcelona, 2009-2011. Master's degree in Forensic Linguistics. IDEC-IULA, Barcelona, 2009-2011. Postgraduate degree in Legal and Judicial Language. IDEC-IULA, Barcelona, 2010. Postgraduate Degree in Expert Judicial Calligraphy, Graphic Arts, Document Analysis and Forensic Socio-linguistics. Universitat Autònoma de Barcelona, Barcelona, 2010. University Degree in Linguistic Mediation. UPF, Barcelona, 2010. - Bachelor in Linguistics. UPF, Barcelona, 2005-2009. - Bachelor's Degree in Translation and Interpretation. UPF, Barcelona, 2005-2009. Online Professor of the Master in the Communication and Social Sciences Faculty from the University of San Jorge, and professor in the Research and Criminal Education Center from the University of Miguel Hernández. Director of professional courses in Forensic Linguistics from the SQ Laboratory. 	<ul style="list-style-type: none"> Doctorate in Translation and Language Sciences. Pompeu Fabra University (UPF). (2015.) 	<ul style="list-style-type: none"> Master in Teaching English as a Foreign Language 	<ul style="list-style-type: none"> FP002 - Observation and Research in the Language Classroom FP004 - Individual Factors FP036 - Teaching English through translation Master Thesis
				Academic Load
				4
				Number of Subjects
				4

MAIN PROFESSORS				
Professor	CV Summary	Doctorate	Program	Courses Taught
Dr. Silvia Aparicio	<ul style="list-style-type: none"> Postgraduate studies, with a scholarship from the Erasmus program (Denmark). Bachelor's degree in Business Administration from the University of Cambria (Spain). Has served in managerial positions and coordination in different educational institutions. Has experience in management positions within private companies. Has made presentations on topics such as entrepreneurship, scientific research, contributory system, finance, marketing, distribution, and the environment, new technology for the Ministry of Agriculture from the Autonomous University of Madrid, Cantabria, Valladolid and Copenhagen. Author and co-author of several newspaper articles of impact and media (El Mundo). 	<ul style="list-style-type: none"> Doctorate in Economics from the Faculty of Economics and Economic Development (Program of Integration and Economic Development) of the Autonomous University of Madrid. (2014) 	<ul style="list-style-type: none"> Master in Strategic Management with a Specialty in Management Master in Strategic Management with a Specialty in Telecommunications Master in Strategic Management with a Specialty in Information Technology 	<ul style="list-style-type: none"> DD126 - Budget and Public Accounting DD128 - Administration and Planning of Audits DD130 - Auditing Procedures by Area DD131 - Audit Reports DD153 - Financial Valuation for IAS DD154 - Internal Control DD155 - Documentation, Tests and Risks DD1008 - Health Services Management TR047 - Financial Management
				Academic Load
				9
				Number of Subjects
9				
Dr. Silvia Pueyo Villa (Department Director)	<ul style="list-style-type: none"> Master in Applied Linguistics to the Teaching of Spanish as a Foreign Language, University of Jaen and the Universidad Internacional Iberoamericana (2008-2009). Master in Teaching Spanish as a Foreign Language, University of Barcelona (1999-2001) Bachelor in Translation and Interpretation, Autonomous University of Barcelona (1997) Academic Director of the Translation and Interpreting and Applied Languages Degrees from the European University of the Atlantic, Santander (2014-2015) Complementary training: <ul style="list-style-type: none"> Course "Training for Directors of Thesis" - FUNIBER (2015) Course on "Teaching in Virtual Environment" - FUNIBER (2015) 	<ul style="list-style-type: none"> Doctorates in the Educational Sciences at the University of Barcelona (Spain).. (2016) 	<ul style="list-style-type: none"> Master in Teaching Spanish as a Foreign Language Doctorate in Education with a Specialty in Research 	<ul style="list-style-type: none"> FP017 - Modes of Directing the Classroom FP028 - Developing Skills in the Classroom FP030 - Educational Technology in Language Learning DD008 - Thesis Proposal DD009 - Thesis Development DD010 - Thesis Dissertation Master's Thesis
				Academic Load
				7
				Number of Subjects
5				
Dr. Silvia Quer Palomas	<ul style="list-style-type: none"> Master in Clinical Psychology and Health, specialty in Clinical Neuropsychology (2012). Master's in Neurosciences - Universitat Autònoma de Barcelona (2010). Bachelor's in Psychology - Universitat Autònoma de Barcelona (2009). 	<ul style="list-style-type: none"> Doctor in Clinical and Health Psychology - Universitat Autònoma de Barcelona (2013). 	<ul style="list-style-type: none"> Master in Physical Activity: Sports Training and Management 	<ul style="list-style-type: none"> DD049 - Neurolinguistic Programming DD093/DD094 - Emotion, Communication and Conflict SN050 - Sport Psychology Master's Thesis
				Academic Load
				4
				Number of Subjects
4				
Dr. Sonia Rodríguez Fernández	<ul style="list-style-type: none"> DEA (Diploma of Advanced Studies) University of Granada. Faculty of Education Sciences. Bachelor's in Psychopedagogy from the University of Granada. Faculty of Education Sciences. Counselors in the Psychopedagogy Cabinet and University Guidance. University of Granada. Participation in R&D projects financed in national and international public calls. 	<ul style="list-style-type: none"> Doctorate in Pedagogy and Psychopedagogy, University of Granada (2003) 	<ul style="list-style-type: none"> Doctorate in Education with a Specialty in Research 	<ul style="list-style-type: none"> FP120 - Creation, Adaptation and Evaluation of Materials
				Academic Load
				1
				Number of Subjects
1				

MAIN PROFESSORS				
Professor	CV Summary	Doctorate	Program	Courses Taught
Dr. Susana de León	<ul style="list-style-type: none"> Bachelors in Electronic Engineering in Technological Institute of Minatitlán. Master of Science in Electronic Engineering by CENIDET, specialization in power electronics. Author of numerous publications. Thesis director at the master's and doctoral levels. 	<ul style="list-style-type: none"> Doctor in Electronic Engineering Sciences. National Center of Research and Development (CENIDET, Spanish acronym), Cuernavaca (Mexico) (2016) 	<ul style="list-style-type: none"> Master in Environmental Management and Auditing Master in Strategic Management with a Specialty in Management 	<ul style="list-style-type: none"> IP082 - Quality Management: ISO 9001 IP9003 - Integration of Management Systems Based on Standards and Processes MA001 - Introduction to Sustainable Development MA010 - Business Environmental Management MA011 - Environmental Audit MA012 - Environmental Impact Assessment MA060 - Photovoltaic Solar Energy MA062 - Wind Energy MA063 - Geothermal Energy MA098 - Business Environmental Management: ISO 14001 Master's Thesis
				Academic Load
				11
				Number of Subjects
				11
Dr. Susana Golçalves	<ul style="list-style-type: none"> Bachelor's Degree in Psychology from the University of Coimbra, Portugal (1985). Master's degree in Psychology (Specialisation in Psychology and Pedagogy), University of Coimbra, Portugal (1996). Has more than 10 years of teaching experience in universities. Has a large number of publications related to: higher education, teaching in higher education, teacher training, intercultural education, education and citizenship and multiculturalism. Has participated in numerous conferences and seminars as a speaker in relation to her areas of expertise. 	<ul style="list-style-type: none"> Doctorate in Psychology from the University of Coimbra, Portugal (2000) 	<ul style="list-style-type: none"> Doctorate in Education with a Specialty in Research 	<ul style="list-style-type: none"> D0008 - Thesis Proposal D0009 - Thesis Development D0010 - Thesis Dissertation
				Academic Load
				3
				Number of Subjects
				1
Dr. Susana Martínez	<ul style="list-style-type: none"> Master's Degree in Occupational Risk Prevention, Board of Castilla and León (2009) Degree in Food Science and Technology Intensified Food Technology, University of León (2004) Bachelor's in Biology (2000) Senior Research Technician, Institute of Biomedicine in León (2013) Several training courses in online teaching. Professor at the University of León. 	<ul style="list-style-type: none"> Doctorate in Biology, University of Leon (2004) 	<ul style="list-style-type: none"> Master in Physical Activity: Sports Training and Management Master in Naturopathic Sciences 	<ul style="list-style-type: none"> FP092- Methodology of Scientific Research SN017 - Nutritional Biochemistry SN039 - Structure and Function of the Human Body SN043 - Ergogenic Aids SN259 - Human Anatomy and Physiology SN260 - Organic Chemistry Master's Thesis
				Academic Load
				7
				Number of Subjects
				7
Dr. Tatiana de los Reyes Suárez Turriza	<ul style="list-style-type: none"> Post-Doctorate in Humanities from the National Autonomous University of Mexico. Master's degree in Mexican literature from the Institute of Linguistic-Literary Research of the University of Veracruzana. Master's degree in Hispanic Literature from the Center for Linguistic and Literary Studies of the Colegio de México. Degree in Hispanic Language and Literature from the Faculty of Spanish Literature at the University of Veracruzana 	<ul style="list-style-type: none"> Doctor in Hispanic Literature from the Center for Linguistic and Literary Studies of the Colegio de México. (2014) 	<ul style="list-style-type: none"> Doctorate in Projects with a Specialty in Research 	<ul style="list-style-type: none"> D0008 - Thesis Proposal D0009 - Thesis Development D0010 - Thesis Dissertation
				Academic Load
				3
				Number of Subjects
				1

MAIN PROFESSORS					
Professor	CV Summary	Doctorate	Program	Courses Taught	
Dr. Vanessa Anaya Moix	<ul style="list-style-type: none"> • Master's in Teacher Training in Spanish as a Foreign Language, University of Barcelona (2001). • Bachelor in Translation and Interpreting from the University of Pompeu Fabra (Spain). • Specialization courses in educational quality and teaching in virtual environments. • International stays of more than 3 years in France and Ireland. • Several publications in journals. 	<ul style="list-style-type: none"> • Doctor of Didactics in Language and Literature from the University of Barcelona (Spain). (2008) 	<ul style="list-style-type: none"> • Master in Teaching Spanish as a Foreign Language • Master in Teaching English as a Foreign Language • Doctorate in Education with a Specialty in Research 	<ul style="list-style-type: none"> • FP011 - Task and projects • FP015 - Curriculum and Course Design - Principles and Practice • FP018 - Observation and Research in the Classroom • FP119 - Learning Factors • FP123 - Educational Counseling and Mentoring • FP124 - Applied Didactics • FP125 - Physical Activity Applied to Education, Health and Performance • FP126 - ICT in Education and Learning Theories • FP127 - Organization and Management of Educational Centers 	
				Academic Load	9
				Number of Subjects	9
Dr. Víctor Jiménez	<ul style="list-style-type: none"> • Bachelor in Civil Engineering by the Autonomous Metropolitan University of Mexico (Mexico). • Master's Degree in Construction Engineering from the National Autonomous University of Mexico (Mexico). • Head and responsible for Health and Safety of the East Sender Tunnel Project (2009-2012) • Technical advisor to the Chamber of Deputies during the construction of the building for the ASF. • Has worked as part of the teaching staff for 58 undergraduate courses, 65 bachelor's courses. • Has participated in the modification of the analytical programs for UEAs (UAM). • Has 5 specialized articles in national magazines. Has also carried out the technical evaluation of a scientific book. • Participated in different national and international congresses. 	<ul style="list-style-type: none"> • Doctorate in Project Engineering at the Polytechnic University of Catalonia (Spain). (2005) 	<ul style="list-style-type: none"> • Master in Strategic Management with a Specialty in Management • Master in Strategic Management with a Specialty in Telecommunications • Master in Strategic Management with a Specialty in Information Technology 	<ul style="list-style-type: none"> • DD1010 - Assistance Quality and Patient Safety • IP002 - Workplace Safety • IP003 - Industrial Hygiene • IP004 - Occupational Health • IP059 - Fundamentals in Occupational Risk Prevention • IP060 - Occupational Safety • IP076 - Workplace Hygiene • Master's Thesis 	
				Academic Load	8
				Number of Subjects	8
Dr. Victor Robles Ramirez	<ul style="list-style-type: none"> • Master's Degree in Educational Computer Science, specializing in Distance Education. • Interamerican University of Puerto Rico, San Germán Campus (2009 - 2011). • Bachelor's in Computer Sciences. Interamerican University of Puerto Rico, San Germán Campus (1983 - 1989). • Courses on computer programming. Hudson County Community College Advanced (1984-1985). 	<ul style="list-style-type: none"> • Doctor in Distance Education, Outstanding Grade. University of Jaén, Jaén, Spain (2017). 	<ul style="list-style-type: none"> • Doctorate in Education with a Specialty in Research • Doctorate in Projects with a Specialty in Research 	<ul style="list-style-type: none"> • D0008 - Thesis Proposal • D0009 - Thesis Development • D0010 - Thesis Dissertation 	
				Academic Load	3
				Number of Subjects	1
Dr. Viviane Brandão	<ul style="list-style-type: none"> • Master in Engineering and Knowledge Management, Federal University of Santa Catarina, Brazil (2012) • Bachelor's Degrees in Information Systems, Federal University of Santa Catarina, Brazil (2006) 	<ul style="list-style-type: none"> • Doctorate in Engineering Production, Federal University of Santa Catarina, Brazil (2019) 	<ul style="list-style-type: none"> • Master in Strategic Management with a Specialty in Management • Master in Strategic Management with a Specialty in Telecommunications • Master in Strategic Management with a Specialty in Information Technology 	<ul style="list-style-type: none"> • DD014 - Strategic Management and Planning • DD068 - Knowledge Management and Organizational Learning • Master's Thesis 	
				Academic Load	3
				Number of Subjects	3

MAIN PROFESSORS					
Professor	CV Summary	Doctorate	Program	Courses Taught	
Dr. Viviane Sartori	<ul style="list-style-type: none"> Master in Engineering and Knowledge Management, Federal University of Santa Catarina (2012). Graduate in Pedagogy, Universidade Estadual de Maringá, UEM, Brazil (1994) Visiting Professor at the Catholic Faculty of Santa Catarina, FACASC, Brazil. PCADIS - Scientific Research Group in Distance Education - 2012 - 2015. Rooms for innovation and entrepreneurship (Via Estação Conhecimento). 	<ul style="list-style-type: none"> Doctorate in Engineering and Knowledge Management, Federal University of Santa Catarina (2017) 	<ul style="list-style-type: none"> Master in Education Doctorate in Education with a Specialty in Research 	<ul style="list-style-type: none"> FP081 - Strategic Management and Planning FP114 - Educational Quality. Evaluation and Innovation FP115 - Work Team Management Techniques Master's Thesis 	
				Academic Load	4
				Number of Subjects	4
Dr. Yaritza María Elba Ferreira	<ul style="list-style-type: none"> Master in Advanced Management in Education, Universidad de Carabobo (2006) Bachelor's in Psychology, University Yacambú (2018) Bachelor's in Education, University Yacambú (2003) 	<ul style="list-style-type: none"> Doctorate in Education, University of Carabobo (2010). 	<ul style="list-style-type: none"> Master in Education 	<ul style="list-style-type: none"> Master's Thesis 	
				Academic Load	1
				Number of Subjects	1
Dr. Yini Miró	<ul style="list-style-type: none"> Master in Project Design, Administration and Management of Architecture and Urban Planning, Puerto Rico UNINI (2014) Architect, University of Los Andes, Merida - Venezuela (2009) Architect, developing projects for interior design, Baobab Design and Manufacture C.A - Merida Venezuela (2014-present) 	<ul style="list-style-type: none"> Doctorate in Project Management. Universidad Internacional Iberoamericana (Mexico) (2020) 	<ul style="list-style-type: none"> Master in Strategic Management with a Specialty in Management Master in Strategic Management with a Specialty in Telecommunications Master in Strategic Management with a Specialty in Information Technology Master in Project Design, Administration and Management Master in Project Design, Administration and Management with a Specialty in Architecture and Urban Planning Master in Project Design, Administration and Management with a Specialty in Innovation and Product 	<ul style="list-style-type: none"> AU004 - Contextual Components of the Project: Economic, Social, Institutional and Cultural AU010 - Integral Management of Design and Product AU016 - Product Design and the Agents of Technology Innovation AU017 - Profit and Strategic Design 	
				Academic Load	4
				Number of Subjects	4
Dr. Yoanky Cordero	<ul style="list-style-type: none"> Course on International Political Relations. Higher Institute of International Relations, Cuba (2005-2007). Graduate in Social Worker Training. University of Havana, Cuba (2002 -2003). Bachelor's in Education. University of Pedagogical Sciences (UCP), Cuba (1998-2002). Collaborating researcher at the Paulista State University (UNESP), Brazil. 	<ul style="list-style-type: none"> Doctor of Arts, Paulista State University (UNESP), Brazil (2012-2016). 	<ul style="list-style-type: none"> Master in Education 	<ul style="list-style-type: none"> FP091- Content and Language Integrated Learning Master's Thesis 	
				Academic Load	2
				Number of Subjects	2

MAIN PROFESSORS				
Professor	CV Summary	Doctorate	Program	Courses Taught
Dr. Yolanda Alarcón	<ul style="list-style-type: none"> • Master of Arts. University of Phoenix, Arizona (1988) • Bachelor of Arts. Interamerican University of Puerto Rico (1986). • Consultant-Speaker of the Educational Curriculum, Strategies and Federal Educational Proposal (as of 2014). • Part-time professor in courses for instructors of the Curriculum in Mentoring, Mathematics and Education Administration. Graduate School. Research Director of the M.A. Graduate Project Caribbean University Of Puerto Rico. (as of 2007). • Undergraduate and graduate associate professor. Graduate in Programed Mathematics, Educational Administration and Supervision. Caribbean University Of Puerto Rico (as of 2008). 	<ul style="list-style-type: none"> • Doctor in Education with a Specialty in Educational Administration. Interamerican University of Puerto Rico (2007) 	<ul style="list-style-type: none"> • Doctorate in Education with a Specialty in Research 	<ul style="list-style-type: none"> • DD008 - Thesis Proposal • DD009 - Thesis Development • DD010 - Thesis Dissertation
				Academic Load
				3
				Number of Subjects
1				

TUTORS				
Professor	CV Summary	Doctorate	Program	Courses Taught
Dr. (c) Alba Hernández	<ul style="list-style-type: none"> • Master in Social Psychology. Faculty of Psychology. University of Havana. (2003) • Bachelor in Psychology, University of La Habana (1996) • Researcher, Business Consultant and Project Chief. Psychological and Sociological Research Center. Havana. Cuba (1998-2015) • Translation of scientific papers from English to Spanish. Chapter translations from the book "El poder de la Indagación Apreciativa" (<i>The Power of Appreciative Inquiry</i>). Acuario Editions. (2011). • Has taught numerous courses, workshops and seminars in Mexico, USA, Spain, Puerto Rico and Cuba. 	<ul style="list-style-type: none"> • Doctorate in Education, Universidad Internacional Iberoamericana, Mexico [Studying] 	<ul style="list-style-type: none"> • Master in Strategic Management with a Specialty in Management 	<ul style="list-style-type: none"> • DD109 - Succession and Continuity in Family Business • DD110 - Systematic Focus Applied to Conflict in Family Businesses • DD115 - Key Factors for Success in the Family Business • DD091/DD092 -Conflict Theory
				Academic Load
				4
				Number of Subjects
4				
Dr. (c) Andrea Gutiérrez	<ul style="list-style-type: none"> • Master's Degree in Human Resources and Knowledge Management, Universidad Internacional Iberoamericana in accordance with the University of León, Barcelona, Spain (2010) • Psychologist, Pontificia Universidad Javeriana, Cali, Colombia (1998) • Coordinator of Organizational Psychology, Integrated Massive Transportation Group Massive GIT S.A. (July 2009 - December, 2010) • Consultant for the Evaluation of Human Development project, Ingacon ltd. (April- July 2008) 	<ul style="list-style-type: none"> • Doctorate in Education, Universidad Internacional Iberoamericana, Mexico [Studying] 	<ul style="list-style-type: none"> • Master in Strategic Management with a Specialty in Management • Master in Strategic Management with a Specialty in Telecommunications • Master in Strategic Management with a Specialty in Information Technology • Master in Project Design, Administration and Management • Master in Project Design, Administration and Management with a Specialty in Architecture and Urban Planning • Master in Project Design, Administration and Management with a Specialty in Innovation and Product 	<ul style="list-style-type: none"> • DD111 - Professionalization of Family Business • DD112 - Governing Structures and Bodies • DD113 - The Family Protocol • DD114 - Property Management in Family Businesses • DD116 - Creation and Internationalization of Family Businesses • DD108 - Family Business Concepts and Characteristics • DD143 - Basic Legal Aspects of the Family Business • TR026 - Business Administration and Management
				Academic Load
				8
				Number of Subjects
8				

TUTORS				
Professor	CV Summary	Doctorate	Program	Courses Taught
Dr. (c) Arlette Zárate	<ul style="list-style-type: none"> Master's in Organizational Psychology from the Instituto de Estudios Universitarios, Mexico. Master's in Educational Administration with a major in Basic Education by Instituto Tecnológico y de Estudios Superiores de Monterrey. Bachelor's in Educational Psychology from the Autonomous University of Campeche. Expert in Psychology by the Mexican Forensic Society. Has experience in managing early childhood, preschool and elementary school centers, as well as in applying recruitment processes, organizational development and workplace environment. Certified trainer by the National Council of Standardization and Certification of Labor Competencies, recognized as an External Training Agent in the Secretariat of Labor and Social Welfare. Experience as an undergraduate and graduate teacher in the areas of education and psychology, as well as a counselor applying processes of vocational and labor guidance based on competencies. 	<ul style="list-style-type: none"> Doctorate in Psychology, Universidad Internacional Iberoamericana (Mexico), [in progress] 	<ul style="list-style-type: none"> Master in Strategic Management with a Specialty in Management 	<ul style="list-style-type: none"> DD024- Organizational Culture and Setting DD030 - Position Analysis, Description and Value DD032 - Performance Evaluation and Management by Competencies DD033 - Compensations and Incentives DD034 - Training and Career Plans DD045 - Emotional Intelligence DD043 - Stress and Burnout
				Academic Load
				7
				Number of Subjects
7				
Dr. (c) Beatriz Suárez	<ul style="list-style-type: none"> Bachelor's in Philology from the University of Vigo (Spain). Master in Teaching Spanish as a Foreign Language, University of Jaen (Spain) 	<ul style="list-style-type: none"> Doctorate's in Philology from the University of Vigo (Spain). 	<ul style="list-style-type: none"> Master in Teaching Spanish as a Foreign Language 	<ul style="list-style-type: none"> FP020 - Individual Factors in Learning FP028 - Developing Skills in the Classroom FP032 - Evaluation of the Learning Process
				Academic Load
				3
				Number of Subjects
3				
Dr. (c) Carmen Lili Rodríguez Velasco	<ul style="list-style-type: none"> Master's Degree in Education, European University of the Atlantic (2018). Master's Degree in Work and Organizational Psychology, University of Havana (2010). Bachelor's in Psychology, Central University of Las Villas (2002) Professional career has been related to teaching, research and consulting in the field of organizational psychology and other related areas. Experience in the coordination of teams for the curricular design of academic programs and the creation of teaching materials, as well as the management and optimization of processes and procedures related to the design and implementation of academic programs in virtual learning environments. Broad participation in Workshops, Seminars, Congresses. Author and co-author of several scientific publications. 	<ul style="list-style-type: none"> Doctorate in Education, Universidad Internacional Iberoamericana, [Studying] 	<ul style="list-style-type: none"> Master in Strategic Management with a Specialty in Management Master in Strategic Management with a Specialty in Information Technology 	<ul style="list-style-type: none"> DD031 - Recruitment, Selection and Promotion DD036 - Human Resources Auditing DD047 - Intellectual Capital DD048 - Quality as a Management Tool for Human Resources
				Academic Load
				4
				Number of Subjects
4				
Dr. (c) Claudia Cataño Hoyos	<ul style="list-style-type: none"> Master in Education, Universidade Federal de Santa Catarina (2015). Master's in social problems: direction and management of social programs, University of Granada (2009). Graduate in Psychology, University of Antioquia (2006). Experience in qualitative research and public policy in education. Four years of professional experience in the direction and management of social programs, three years of experience in the implementation and evaluation of public policies, development of projects for the protection, demand and vindication of human rights. 	<ul style="list-style-type: none"> Doctorate in Education, Federal University of Santa Catarina (Studying) 	<ul style="list-style-type: none"> Master in Education 	<ul style="list-style-type: none"> FP078- Interculturality and Education FP080- Conflict Solution and Transformation in the Educational Environment FP082 - Planning and Management of Projects FP088- Creation, adaptation and evaluation of materials FP106 - Curricular Design, Programming and Outcome Development FP107 - Classroom learning methodologies
				Academic Load
				6
				Number of Subjects
6				

TUTORS				
Professor	CV Summary	Doctorate	Program	Courses Taught
Dr. (c) Cristina Arazola	<ul style="list-style-type: none"> . Master's Degree in Research and Teaching in Physical Activity and Health Science, University of Jaen, Spain (2017) . Doctor in, University of Saragossa, Spain (2016). 	<ul style="list-style-type: none"> • Doctor in Teaching Innovation and Teacher Training, University of Jaén (Spain) and University of Boras (Sweden) [in progress] 	<ul style="list-style-type: none"> • Master in Education 	• FP087- Learning Factors
				Academic Load
				1
				Number of Subjects
1				
Dr. (c) Daniela Torrico	<ul style="list-style-type: none"> • Master's Degree in Marketing and Commercial Distribution, Polytechnic University of Catalonia Barcelona, Spain (2008 - 2009) • Master in Business Administration (MBA), La Salle Business Engineering School, Barcelona, Spain (2007 - 2008) • Assistant in the Finance and Expansion Department, HOTUSA, Barcelona, Spain (2008 - 2009) • Account Executive, ENTEL S.A., La Paz, Bolivia (2006 - 2007) 	<ul style="list-style-type: none"> • Doctorate in Projects, Marketing Research from the Universidad Internacional Iberoamericana [in progress] 	<ul style="list-style-type: none"> • Master in Strategic Management with a Specialty in Management • Master in Strategic Management with a Specialty in Telecommunications • Master in Strategic Management with a Specialty in Information Technology 	• DD159 - Introduction to the New Marketing
				• DD161 - Consumer-Buyer Behavior
				• DD170 - Marketing Services
				• DD1009 - Heath Marketing
Academic Load				
4				
Number of Subjects				
4				
Dr. (c) Elena Caixal	<ul style="list-style-type: none"> • Master in Applied Linguistics to the Teaching of English as a Foreign Language, University of Jaen and the Universidad Internacional Iberoamericana (2011) • Master in Applied Linguistics to the Teaching of Spanish as a Foreign Language, University of Jaen and the Universidad Internacional Iberoamericana (2010) • Complementary training: <ul style="list-style-type: none"> - Course "Training for Directors of Thesis" - FUNIBER (2015) - Course on "Teaching in Virtual Environment" - FUNIBER (2015) 	<ul style="list-style-type: none"> • Doctorate in Education. Universidad Internacional Iberoamericana (Mexico) [in progress] 	<ul style="list-style-type: none"> • Master in Teaching Spanish as a Foreign Language • Master in Teaching English as a Foreign Language 	• FP017 - Modes of Directing the Classroom
				Academic Load
				1
				Number of Subjects
1				
Dr. (c) Elisangela Faustino	<ul style="list-style-type: none"> • Master in Information Sciences, Federal University of Santa Catarina, Brazil (2012). • Bachelor in German Literature, Federal University of Santa Catarina, Brazil (2009). • Bachelor in History, Federal University of Santa Catarina, Brazil (2006). 	<ul style="list-style-type: none"> • Doctorate in Projects. Universidad Internacional Iberoamericana (Mexico) [in progress] 	<ul style="list-style-type: none"> • Master in Strategic Management with a Specialty in Management • Master in Strategic Management with a Specialty in Telecommunications • Master in Strategic Management with a Specialty in Information Technology • Master in Project Design, Administration and Management • Master in Project Design, Administration and Management with a Specialty in Architecture and Urban Planning • Master in Project Design, Administration and Management with a Specialty in Innovation and Product 	• DD012 - Management and Operational Direction
				• DD013 - Logistics
				• DD022 - Organizational Structure and Change
				• DD040 - Negotiation and Conflict Resolution Techniques
• DD041 Work Team Management Techniques:				
• DD043 - Stress and Burnout				
• DD044 - Public Speaking Techniques				
• TI011 - Society of Change and Information.				
• TI017 - Integration of Business Management Systems				
• TI025 - e-Business and its Integration with Corporate Management Systems				
Academic Load				
10				
Number of Subjects				
10				

TUTORS				
Professor	CV Summary	Doctorate	Program	Courses Taught
Dr. (c) Erik Simoes	<ul style="list-style-type: none"> Master in Aquaculture by the Postgraduate Program in Aquaculture at the Federal University of Santa Catarina (2011). Degree in Aquaculture, Federal University of Santa Catarina, UFSC, Brazil (2009). 	<ul style="list-style-type: none"> Doctorate in Projects, Universidad Internacional Iberoamericana (Mexico), [Studying] 	<ul style="list-style-type: none"> Master in Environmental Management and Auditing 	<ul style="list-style-type: none"> MA028 - Potentially Contaminated Marine Ecosystems MA029 - Environmental Factors that Affect Pollutants MA030 - Contaminating Agents MA031 - Toxicology MA073 - Natural Areas in the Context of Societies MA078 - Management of Natural Spaces MA079 - Ecologic Restoration and Landscaping MA080 - Case studies of Management and Conservation of Natural Spaces MA109 - Marine Culture MA136 - Technology in Marine Aquaculture MA140 - Fisheries Management
				Academic Load
				11
				Number of Subjects
				11
Dr. (c) Eugenia Falabella	<ul style="list-style-type: none"> Master's Degree in Linguistics Applied to the Teaching English as a Foreign Language. University of Jaen (official) (2010). Postgraduate/Specialization in Teaching in Virtual Learning Environments. National University of Quilmes. Virtual University of Quilmes (2016). Bachelor of Arts in Teaching English, Catholic University of La Plata (UCALP) (2016). Professional experience in face-to-face (primary, secondary and tertiary/university), blended and distance education. 	<ul style="list-style-type: none"> Doctorate in Education. Universidad Internacional Iberoamericana (Mexico) [in progress] 	<ul style="list-style-type: none"> Master in Teaching English as a Foreign Language 	<ul style="list-style-type: none"> FP003 - Second language acquisition FP006 - Methodological Approaches:
				Academic Load
				2
				Number of Subjects
				2
Dr. (c) Fabricio De Paula	<ul style="list-style-type: none"> Master in Project Design, Administration and Management, University of León, Spain (2013). Architect, Faculty of Architecture, University of the Republic, MVD (2006) Competencies Certification in Project Management. IPMA, Level D. AGPA, IPMA. Buenos Aires, Argentina (2016). Teaching Professor - Fundación Universitaria Iberoamericana (December, 2015). Teaching course in a virtual environment - 175h, Iberoamerican University Foundation (June, 2015) Teaching of Professional Employment Practice, Faculty of Architecture, University of the Republic MVD (2009- -2012). 	<ul style="list-style-type: none"> Doctorate in Projects. Universidad Internacional Iberoamericana (Mexico) [in progress] 	<ul style="list-style-type: none"> Master in Project Design, Administration and Management with a Specialty in Innovation and Product 	<ul style="list-style-type: none"> AU014 - Theory of the Object AU015 - Relationship between Innovation, Creativity, Productivity, and Competitiveness DD050 - Introduction to Projects DD051 - Project System Design DD052 - Analysis of Provision of Services DD053 - Functional Analysis of the Project DD054 - Project Ergonomics DD055 - Project Security and Reliability DD056 - Environment in a Project DD057 - Project Specifications DD058 - Project Draft Preparation
				Academic Load
				11
				Number of Subjects
				3

TUTORS					
Professor	CV Summary	Doctorate	Program	Courses Taught	
Dr. (c) Fernanda Fauth	<ul style="list-style-type: none"> Master's Degree in Research in Didactics, Training and Evaluation. University of Barcelona, UB, Spain (2013) Bachelor's in Physical Education. Federal University of Santa Catarina, UFSC, Brazil (2010) Collaborator, Functional framework: researcher at the University of Barcelona Project Participation Activities: 2012- 2013 Living and learning with new literacies in and out of secondary school: contributions in reducing early school withdrawal, exclusion and disaffection among young people. 2013 - 2013 scholarship holder: Agència de Gestió d'Ajuts Universitaris i de Recerca (AGAUR): Scholarships for academic activities aimed at supporting the teaching staff in the public universities of the Catalan university system and the Universitat Oberta de Catalunya (Open University of Catalonia, AAD). 	<ul style="list-style-type: none"> Doctoral student of the Arts and Education program, University of Barcelona, UB. 	<ul style="list-style-type: none"> Master in Education 	<ul style="list-style-type: none"> FP101 - Learning Theories and Methodological Approaches in Education FP102- Strategic Learning and Professional Development FP110 - Training in Virtual Learning Environments FP112 - Design and Evaluation of Training Proposals Based on ICT Portfolio I, II, III 	
				Academic Load	4
				Number of Subjects	4
Dr. (c) Irma Domínguez	<ul style="list-style-type: none"> Master in Physical Activity: Sports Training and Management. International and Inter-University Master's program in Nutrition and Applied Dietetics specializing in Eating Disorders And Nutrition and Aging from the University of Leon (Spain). University Degree in Human Nutrition and Dietetics from the University of Navarra (Spain). 	<ul style="list-style-type: none"> Doctorate in Education by the Universidad Internacional Iberoamericana [Mexico (Studying)] 	<ul style="list-style-type: none"> Master in Physical Activity: Sports Training and Management Master in Naturopathic Sciences 	<ul style="list-style-type: none"> SN018- Evaluation of the Nutritional State SN047 - Eating Disorders in Sports SN198 - Basic Aspects of Nutrition SN217 -Nutrition and Sport 	
				Academic Load	4
				Number of Subjects	4
Dr.(c) Johanna Loaiza	<ul style="list-style-type: none"> Master in Economic and Financial Administration, Technological University of Pereira. Industrial Engineer, Technological University of Pereira. Experience in planning, execution and management of social-based projects with public and private entities. Advisor in administrative and financial areas for technology-based enterprises in the discovery phase for the formulation of proposals, projects, resource management, budget preparation and analysis. Trainer in technological education processes with young people belonging to the public and private education system, promoting scientific, creative and innovative thinking. Leader in the management of processes and strategies for innovation, science, technology and entrepreneurship in the public sector. 	<ul style="list-style-type: none"> Doctorate in Projects, Universidad Internacional Iberoamericana, [Studying] 	<ul style="list-style-type: none"> Master in Strategic Management with a Specialty in Management 	<ul style="list-style-type: none"> DD121 - International Taxation and Financing DD123 - Financial Statement Analysis DD128 - Administration and Planning of Audits DD130 - Auditing Procedures by Area DD131 - Audit Reports DD154 - Internal Control DD155 - Documentation, Tests and Risks 	
				Academic Load	7
				Number of Subjects	7
Dr. (c) Karina Nossar	<ul style="list-style-type: none"> Master's Degree in Teaching Spanish as a Foreign Language, Universidad Internacional Iberoamericana, (2012-2014). Master's Degree in Education with emphasis on research in teaching and learning University ORT Uruguay. (2005) Degree in teaching Spanish Language Artigas Teachers Institute, National Public Education Administration, Uruguay (1991) Degree in teaching Literature Artigas Teachers Institute, National Public Education Administration, Uruguay (1985) Assistant director, reserve position, (40 hours per week), Instituto de Profesores Artigas, Uruguay. 2009 – Present Director, (40 hours per week / total dedication), CERP del Norte, Uruguay. 2002 - Present 	<ul style="list-style-type: none"> Doctoral student in Education, Faculty of Education Sciences, Business University, Uruguay (2008). 	<ul style="list-style-type: none"> Master in Education 	<ul style="list-style-type: none"> FP082 - Planning and Management of Projects FP104- Organization and Management of Educational Centers FP114 - Educational Quality. Evaluation and Innovation FP115 - Work Team Management Techniques 	
				Academic Load	7
				Number of Subjects	7

TUTORS				
Professor	CV Summary	Doctorate	Program	Courses Taught
Dr. (c) Kathilça Lopes de Souza	<ul style="list-style-type: none"> Master's Degree in Education with specialization in Teacher Training, UNINI (2018). Graduate in Art and Literature - French, Federal University of Santa Catarina (2015). External tutor at the Leonardo da Vinci University Center, UNIASSELVI, Brazil Teacher at Florianópolis City Hall, PMF, Brazil. 	<ul style="list-style-type: none"> Doctorate in Education. Universidad Internacional Iberoamericana (Mexico) [in progress] 	<ul style="list-style-type: none"> Master in Education 	<ul style="list-style-type: none"> FP101 - Learning Theories and Teaching Methodological Bases Portfolio I, II, III
				Academic Load
				2
				Number of Subjects
2				
Dr. (c) Leonardo de Jesús Hernández Cruz	<ul style="list-style-type: none"> Master in Physical Activity (2010) Postgraduate specialist in Handball for High Performance by the University of Physical Culture and Sport Sciences, Huguin Faculty, Cuba (2012). Degree in Physical Culture (1997). Diploma in Sports Training (2005). Professor at the Universidad Internacional Iberoamericana. 	<ul style="list-style-type: none"> Doctorate in Education by the Universidad Internacional Iberoamericana, Mexico [in progress] 	<ul style="list-style-type: none"> Master in Physical Activity: Sports Training and Management 	<ul style="list-style-type: none"> SN048 - Training Theory and Practice SN049 - Sports Planning SN228 - Study and Case Resolution for Sports Training
				Academic Load
				3
				Number of Subjects
3				
Dr. (c) Liliana Valdés	<ul style="list-style-type: none"> Master in Marketing and Digital Publicity. Grupo IMF Formación (2016) Master in Business Administration, Economics Faculty, University of Havana, Cuba (2009-2011) University program: Bachelor in Psychology, University of Havana, Cuba (2003-2008) Collaborator of the Enjoycuba Travel Agency, specialist in tours to Cuba (2012) 	<ul style="list-style-type: none"> Doctorate in Projects, Universidad Internacional Iberoamericana (Mexico), [Studying] 	<ul style="list-style-type: none"> Master in Strategic Management with a Specialty in Management 	<ul style="list-style-type: none"> TR022 - Hotel Business Management TR023 - Food and Drinks Management TR027 - Cultural Heritage and Tourism TR030 - Rural Tourism and Sustainable Development TR031 - Alternative Tourism and Ecotourism TR043 - Tourism Foundations TI049 - Quantitative Analysis of Tourism
				Academic Load
				7
				Number of Subjects
7				
Dr. (c) María E. Luna Borgaro	<ul style="list-style-type: none"> Master's Degree in Human Resources and Knowledge Management, University of Leon, Spain (2007 -2009) Bachelor in Psychology, University of Guadalajara (1982 - 1987) Professor in the Master in Administrative Skills, University College (2001-2010) Complementary training: <ul style="list-style-type: none"> Course "Training for Teachers" - FUNIBER (2015). Course "Training for Directors of Thesis" - FUNIBER (2015) Course on "Teaching in Virtual Environment" - FUNIBER (2015) 	<ul style="list-style-type: none"> Doctorate in Education, Universidad Internacional Iberoamericana, Mexico [Studying] 	<ul style="list-style-type: none"> Master in Physical Activity: Sports Training and Management Master in Strategic Management with a Specialty in Management Master in Strategic Management with a Specialty in Telecommunications Master in Strategic Management with a Specialty in Information Technology Master in Project Design, Administration and Management Master in Project Design, Administration and Management with a Specialty in Architecture and Urban Planning Master in Project Design, Administration and Management with a Specialty in Innovation and Product 	<ul style="list-style-type: none"> DD022 - Organizational Structure and Change DD039 - Interpersonal Communication Technique DD041 Work Team Management Techniques: DD042 -Time Management and Conducting Meetings DD044 - Public Speaking Techniques DD1021 - Strategic Management of Human Resources TR024 - Management Techniques and Organizational Leadership TR046 - Strategic Management of Human Resources
				Academic Load
				8
				Number of Subjects
8				

TUTORS				
Professor	CV Summary	Doctorate	Program	Courses Taught
Dr. (c) María Fernanda Figueroa	<ul style="list-style-type: none"> • Master in Strategic Sports Management, University of Barcelona (2011-2013). • Bachelor in Sports Management and Bachelor in Business Administration, Iowa Wesleyan College (2010). • Complementary training: <ul style="list-style-type: none"> - Course "Training for Teachers" - FUNIBER (2015). - Course "Training for Directors of Thesis" - FUNIBER (2015) - Course on "Teaching in Virtual Environment" - FUNIBER (2015) 	<ul style="list-style-type: none"> • Doctorate in Education [in process] 	<ul style="list-style-type: none"> • Master in Physical Activity: Sports Training and Management • Master in Strategic Management with a Specialty in Management • Master in Strategic Management with a Specialty in Telecommunications • Master in Strategic Management with a Specialty in Information Technology 	<ul style="list-style-type: none"> • DD046 - Personal Marketing • DP001 - Administration and Management of Sport Entities • DP002 - Strategic Management and Planning of Sport Organizations • DP004 - Management Techniques for Sports Teams • DP006 - Techniques for Management and Leadership in Sports • TI011 - Society of Change and Information. • TI017 - Integration of Business Management Systems • TI018 - Innovation, Culture and Work Management in the Communication Society
				Academic Load
				9
				Number of Subjects
9				
Dr. (c) María M. Peña Rodríguez	<ul style="list-style-type: none"> • International Professional Certification Level D as Project Management Association (IPMA). • Master's Degree in Design, Management and Project Direction from the European University Miguel de Cervantes (2015). • Master in Cultural Management, Carlos III of Madrid University. • Architect, Faculty of Architecture, University of the Republic. 	<ul style="list-style-type: none"> • Doctorate in Projects, Universidad Internacional Iberoamericana (Mexico), [Studying] 	<ul style="list-style-type: none"> • Master in Project Design, Administration and Management with a Specialty in Architecture and Urban Planning 	<ul style="list-style-type: none"> • AU001 - Architecture and Urbanism Interrelations • DD050 - Introduction to Projects • DD051 - Project System Design • DD052 - Analysis of Provision of Services • DD053 - Functional Analysis of the Project • DD054 - Project Ergonomics • DD055 - Project Security and Reliability • DD056 - Environment in a Project • DD057 - Project Specifications • DD058 - Project Draft Preparation
				Academic Load
				10
				Number of Subjects
2				
Dr. (c) Mariela Rodríguez	<ul style="list-style-type: none"> • Master's Degree in Design, Management and Project Management with major in Architecture and Urbanism (2014). • Architect (2010). • Professor of Architecture at the Catholic University of Santa Fe, Posadas (2013-Present). • Competencies Certification in Project Management. IPMA, Level D. AGPA, IPMA. Buenos Aires, Argentina (2016). • Postgraduate course in Contemporary Architecture Within Historical Contexts. Catholic University of Santa Fe, Posadas (2009). • Postgraduate course "Identity and Architecture: Postmodernity and Heritage". Catholic University of Santa Fe, Posadas (2011). • Course on "Training Tutors for Distance Learning Academic Proposals". Catholic University of Santa Fe, Posadas (2016). • Course "Training course for Professionals in the Teaching Practice". Catholic University of Santa Fe, Posadas (2011). 	<ul style="list-style-type: none"> • Doctorate in Projects, Universidad Internacional Iberoamericana (Mexico), [Studying] 	<ul style="list-style-type: none"> • Master in Project Design, Administration and Management with a Specialty in Architecture and Urban Planning 	<ul style="list-style-type: none"> • AU006 - Architectural-Urban Project Theory • DD050 - Introduction to Projects • DD051 - Project System Design • DD052 - Analysis of Provision of Services • DD053 - Functional Analysis of the Project • DD054 - Project Ergonomics • DD055 - Project Security and Reliability • DD056 - Environment in a Project • DD057 - Project Specifications • DD058 - Project Draft Preparation • DD077 - Project Communication
				Academic Load
				11
				Number of Subjects
3				

TUTORS					
Professor	CV Summary	Doctorate	Program	Courses Taught	
Dr. (c) Martín Barcala Furelos	<ul style="list-style-type: none"> Master's Degree in Physical Education (UDC, Spain). Bachelors Degree in Physical Activity and Sports Sciences, (UCLM, Spain). Master in Teaching Spanish as a Foreign Language (UNEATLANTICO, Spain). 	<ul style="list-style-type: none"> Doctorate in Physical Activity and Sports, Universidad Internacional Iberoamericana (Mexico), [Studying] 	<ul style="list-style-type: none"> Master in Physical Activity: Sports Training and Management 	<ul style="list-style-type: none"> SN039 - Structure and Function of the Human Body SN156 - Psychosocial Aspects of Physical Activity for Health SN159 - Physical Activity in Children and Teenagers 	
				Academic Load	3
				Number of Subjects	3
Dr (c) Mauricio Pulgarín	<ul style="list-style-type: none"> Master in Economic and Financial Management, Technological University of Pereira (2008 - present) Public Accounting, Universidad Libre (2004) Bachelor's, Colegio Diocesano Pereira (1996) Accounting and Financial Advisor, Comdinamica LTDA, (February 2010 – present) Treasurer-Accountant, Asociación Ecociudad (June 2008 – present) Fiscal Reviewer, Sociedad de San Vicente de Paúl (January 2007 – present) Santo Tomas University - Open and Distance Education (January - December 2008) Politécnico Metropolitano (January 2008- December 2008) 	<ul style="list-style-type: none"> Doctorate in Projects. Universidad Internacional Iberoamericana (Mexico) [in progress] 	<ul style="list-style-type: none"> Master in Strategic Management with a Specialty in Management Master in Strategic Management with a Specialty in Telecommunications Master in Strategic Management with a Specialty in Information Technology 	<ul style="list-style-type: none"> DD002 - Management and Cost Control DD120 - Financial Mathematics DD122 - International Accounting Standards DD124 - Management Accounting DD126 - Budget and Public Accounting DD153 - Financial Valuation for IAS TR047 - Financial Management 	
				Academic Load	7
				Number of Subjects	7
Dr. (c) Nelson Yepes	<ul style="list-style-type: none"> Master in Project Design and Management, Bogotá D.C., Universidad Internacional Iberoamericana UNINI, Polytechnic University of Catalonia Iberamerican University, (2008- -2010). Professor of Industrial Engineering, University Uniagustiniana, Bogotá D.C. (2011 - present). CVIac (Colciencias) Research Professor University of Antonio Nariño, UAN (2004 - present). Complementary training: <ul style="list-style-type: none"> Course "Training for Directors of Thesis" - FUNIBER (2015). Course on "Training for Teachers" - FUNIBER (December 2015). Course on "Teaching in the virtual field" FUNIBER, 175 hours (July 2015). 	<ul style="list-style-type: none"> Doctorate in Projects, with emphasis on Industrial Technology, Bogotá D.C, 2014 Universidad Internacional Iberoamericana UNINI, Mexico (studying) 	<ul style="list-style-type: none"> Master in Project Design, Administration and Management 	<ul style="list-style-type: none"> DD050 - Introduction to Projects DD051 - Project System Design DD052 - Analysis of Provision of Services DD053 - Functional Analysis of the Project DD054 - Project Ergonomics DD055 - Project Security and Reliability DD056 - Environment in a Project DD057 - Project Specifications DD058 - Project Draft Preparation DD072 - Computing Tools for Project Management DD075 - Trust Management: Risk and Quality. 	
				Academic Load	11
				Number of Subjects	3
Dr. (c) Pablo Urquizo	<ul style="list-style-type: none"> Master's Degree in Strategic Management in ICT's University of León (Spain). Master's Degree in Training Course for Chiefs of Staff General Command of the Army (Uruguay). Instructor at the Army Peace Operations School (1998-2006). Computer Science Instructor - I.M.A.E. (2001-2006). Teacher of Computer Science - Liceo N°1 Extra-age E.S.O.E. (2001-2006). Teacher of Drawing - Liceo N°1 Extra-age E.S.O.E. (1996). Teacher of Mathematics - Liceo N°1 Extra-age E.S.O.E. (2001 – 2006) 	<ul style="list-style-type: none"> Doctorate in Projects, Universidad Internacional Iberoamericana (Mexico), [Studying] 	<ul style="list-style-type: none"> Master in Project Design, Administration and Management Master in Project Design, Administration and Management with a Specialty in Architecture and Urban Planning Master in Project Design, Administration and Management with a Specialty in Innovation and Product Doctorate in Projects with a Specialty in Research 	<ul style="list-style-type: none"> PC002 - Collaboration and Development Theory PC012 - International Collaboration System PC013 - Logical Framework 	
				Academic Load	3
				Number of Subjects	3

TUTORS					
Professor	CV Summary	Doctorate	Program	Courses Taught	
Dr. (c) Rita Hauce	<ul style="list-style-type: none"> Master in Educational Sciences, University of Matanzas, Cuba (2020). Degree in Biology and Chemistry, University of Matanzas, Cuba (2019) Professor at the Higher Polytechnic Institute of Cuito, Angola, since 2020 	<ul style="list-style-type: none"> Doctorate in Education, Universidad Internacional Iberoamericana, Mexico [Studying] 	<ul style="list-style-type: none"> Master in Education 	<ul style="list-style-type: none"> FP104 - Organization and Management of Educational Centers FP109 - ICT in Education and Learning Theories 	
				Academic Load	2
				Number of Subjects	2
Dr. (c) Rosana Oddone	<ul style="list-style-type: none"> Master's in Project Design, Administration and Management (2008-2010) Architecture, University of the Republic, Faculty of Architecture (2006) Construction Manager, Stiler S.A. Construction Company (August 2015 - present) Construction Manager, Stiler S.A. Construction Company (February - July 2015) Complementary training: <ul style="list-style-type: none"> Course: "Training for Directors of Thesis" - FUNIBER (December, 2015) Course: "Training for Teachers" - FUNIBER December (2015). 	<ul style="list-style-type: none"> Doctorate in Projects. Universidad Internacional Iberoamericana (Mexico) [in progress] 	<ul style="list-style-type: none"> Master in Project Design, Administration and Management with a Specialty in Architecture and Urban Planning 	<ul style="list-style-type: none"> AU003 - Technology Impact in Urban Architectural Projects: DD050 - Introduction to Projects DD051 - Project System Design DD052 - Analysis of Provision of Services DD053 - Functional Analysis of the Project DD054 - Project Ergonomics DD055 - Project Security and Reliability DD056 - Environment in a Project DD057 - Project Specifications DD058 - Project Draft Preparation 	
				Academic Load	10
				Number of Subjects	2
Dr. (c) Sara Moza	<ul style="list-style-type: none"> Masters Degree in Teacher Training, University of Seville (2014) Master's Degree in Human Resources. Legal Studies Centers of Granada (2013) Human Resources Technician, GFI Computing (August - November 2015) Complementary training: <ul style="list-style-type: none"> Training for Teachers FUNIBER (December 2015). Training for Thesis Directors, FUNIBER (December 2015). Teaching in the virtual environment, FUNIBER, 175 hours (July 2015) 	<ul style="list-style-type: none"> Doctorate in Education. Universidad Internacional Iberoamericana (Mexico) [in progress] 	<ul style="list-style-type: none"> Master in Strategic Management with a Specialty in Management Master in Strategic Management with a Specialty in Telecommunications Master in Strategic Management with a Specialty in Information Technology 	<ul style="list-style-type: none"> DD093/DD094 - Emotion, Communication and Conflict DD103 - Conflict Resolution/ Transformation in the Organization DD138 - Conflict Resolution/ Transformation Principles and Processes 	
				Academic Load	3
				Number of Subjects	3
Dr. (c) Sonia Pérez	<ul style="list-style-type: none"> Master in Music Therapy, National University of Colombia, Bogotá 2010. Psychology, Open and Distance National University, Bogotá 2015. Anthropology, University of the Andes, Bogota 2007. Professor of Business Ethics, Polytechnic University Granacolombiano, Bogota 2016-present. Professor of professional ethics and research methodology for all professional technician programs. Methodological Adviser for degree works, University Workshop 5, design center 2014- present. High competency in the development of educational, social and therapeutic processes from capacity-based comprehension, analysis and proactive vision, from a point of view that combines the strategic with the functional-operational. 	<ul style="list-style-type: none"> Doctorate in Education by the Universidad Internacional Iberoamericana, Mexico [in progress] 	<ul style="list-style-type: none"> Master in Strategic Management with a Specialty in Management Master in Strategic Management with a Specialty in Telecommunications Master in Strategic Management with a Specialty in Information Technology 	<ul style="list-style-type: none"> DD090 - Business Ethics and Corporate Social Responsibilities DD101 - Conflict Resolution/ Transformation in the Family FP092- Methodology of Scientific Research 	
				Academic Load	3
				Number of Subjects	3

TUTORS				
Professor	CV Summary	Doctorate	Program	Courses Taught
Dr. (c) Stephen Bonilla	<ul style="list-style-type: none"> Master's Degree in Engineering and Science of Non-Conventional Materials from the University of São Paulo (2015). Environmental Engineer, graduated from the National University (2008). Quality and Project Manager - Proteins and Energy of Colombia (PROTEICOL), Bogota (2010-2013). Environmental Advisor - Productos Biológicos Perkins LTDA, (2009 -2010). Undergraduate thesis researcher - National University of Colombia, Palmira (2007- -2008). 	<ul style="list-style-type: none"> Doctorate in Projects. Universidad Internacional Iberoamericana (Mexico) [in progress] 	<ul style="list-style-type: none"> Master in Environmental Management and Auditing 	<ul style="list-style-type: none"> MA003 - Water Treatment MA007 - Noise Pollution MA009 - Soil Pollution MA010 - Business Environmental Management MA013 - Economy and the Environment MA074 - Biodiversity MA075 - Natural Spaces: Typology and Processes MA077 - The Conservation of Species and Natural Areas MA105 - Sea Water MA107 - Sea Water Chemistry
				Academic Load
				10
				Number of Subjects
				10
Dr. (c) Thomas Prola	<ul style="list-style-type: none"> Master in Teaching and Learning Environments Mediated by Digital Technologies, Universitat de Barcelona, Spain (2018) Master in Social Anthropology, Université de Nice, France (2007) Degree in Social Anthropology, Université de Nice, France (2005) Professor at the European University of the Atlantic, Spain (as of 2018). Associate Professor at the Universitat de Barcelona, Spain (as of 2015). 	<ul style="list-style-type: none"> Doctorate in Education and Society, University of Lisbon [in progress] 	<ul style="list-style-type: none"> Master in Education 	<ul style="list-style-type: none"> FP077- ICT in the Classroom. Educational Applications and Use of Resources
				Academic Load
				1
				Number of Subjects
				1
Dr.(c) Tulassy Rico	<ul style="list-style-type: none"> Master in animal biology by the Federal University of Rio Grande do Sul, Porto Alegre (Brazil). Bachelor in Biology from the Francisco José de Caldas District University, Bogota (Colombia). Field assistant in herpetology, data analysis and environmental impact assessment. 	<ul style="list-style-type: none"> Doctorate in Projects. Universidad Internacional Iberoamericana (Mexico) [in progress] 	<ul style="list-style-type: none"> Master in Environmental Management and Auditing 	<ul style="list-style-type: none"> MA002 - Ecology MA004 - Waste Management MA008 - Natural Resources MA014 - Environmental Law MA016 - The Water Cycle MA017 - Water Management MA076 - Uses of Natural Spaces MA100 - Coastline and Marine Erosion MA137 - Biological Pollution Management
				Academic Load
				9
				Number of Subjects
				9
Dr. (c) Vanessa Yélamos	<ul style="list-style-type: none"> Master's Degree in Integral Coaching from Coaching Higher Institute and Motivat Barcelona Group. CCP ADESCO Accreditation (Spanish Association in Coaching) Master's Degree in Systemic Coaching from the Autonomous University of Barcelona and the Systemic Institute of Barcelona. Mentoring program with mentoring sessions valid for ICF ACC Accreditation. (International Coach Federation) Currently awaiting formal examination for ACC Accreditation by ICF. Specialist Course in Coaching Techniques. Program with ACSTH Accreditation by the ICF (International Coach Federation) Classroom course taught by Gonzalo Silió. Digital Transformation in the classroom: an activity to incorporate Face-to-face course in Systemic Coaching - Family Constellations. Module II. Barcelona: Online Course in Thesis Director Training. Online Course in Professor/Tutor Training Online Course in Social and Educational Interventions. IL3 University of Barcelona. Face-to-face course in Systemic Coaching - Family Constellations. Module I Barcelona Personal-Integral Coach. Through the systemic, ontological and transformational approach 	<ul style="list-style-type: none"> Doctorate in Psychology, Universidad Internacional Iberoamericana (Mexico), [in progress] 	<ul style="list-style-type: none"> Master in Strategic Management with a Specialty in Management 	<ul style="list-style-type: none"> DD049 - Neurolinguistic Programming DD372- Organizational Leadership and Coaching
				Academic Load
				2
				Number of Subjects
				2

TUTORS				
Professor	CV Summary	Doctorate	Program	Courses Taught
Dr. (c) Verónica Andrea Cabañas de Romero	<ul style="list-style-type: none"> Senior professor of English language and literature, graduated from the Faculty of Philosophy and Literature from the National University of Cuyo. Certified English translator of the Supreme Court of Justice Specialist in university teaching, degree endorsed by the Faculty of Philosophy and Letters, National University of Cuyo (2004). Assistant professor and tutor through the virtual platform of the Faculty of Sciences Applied to Industry, National University of Cuyo, 	<ul style="list-style-type: none"> Doctorate in Education. Universidad Internacional Iberoamericana (Mexico) [in progress] 	<ul style="list-style-type: none"> Master in Teaching English as a Foreign Language Master in Teaching Spanish as a Foreign Language 	<ul style="list-style-type: none"> FP011 - Tasks & Projects FP014 - Learning Strategies FP015 - Curriculum & Course Design FP030 - Educational Technology in Language Learning
				Academic Load
				4
				Number of Subjects
4				
Dr. (c) Vivian Lipari	<ul style="list-style-type: none"> Master in Public Health - Chile, University of Chile (March, 2009- January, 2012) Master (c) in Public Health Administration - Peru, National University of Federico Villarreal (March, 2006-March, 2008) Dental Surgeon, Private University San Martín de Porres - Faculty of Dentistry (2005) Professor in the Department of Dentistry, Humanization of Health Program, University of Finis Terrae (July 2012 - present) Complementary training: <ul style="list-style-type: none"> - Course on "Teaching in Virtual Environment" FUNIBER, 175 hours (September 2014). 	<ul style="list-style-type: none"> Doctorate in Projects. Universidad Internacional Iberoamericana (Mexico) [in progress] 	<ul style="list-style-type: none"> Master in Strategic Management with a Specialty in Management 	<ul style="list-style-type: none"> DD1004 - Health Economics DD1007 - Health Planning DD1008 - Health Services Management DD1010 - Assistance Quality and Patient Safety DD1012 - Health Economics DD1013 - Clinical Epidemiology
				Academic Load
				5
				Number of Subjects
5				

PROFESSORS RECRUITED UNDER CONDITIONS OF EXCEPTIONAL MERIT				
Professor	CV Summary	Doctorate	Program	Courses Taught
Dr. (c) Luis Miguel Becerra	<ul style="list-style-type: none"> Master's Degree in Biological-Naturist Studies, University of Leon (2011). Barcelona, Spain. (2014). Major in Clinical Nutrition and Advanced Food Science, University of Barcelona. (2016). Specialist in Immunonutrition, Catholic University of Valencia, Spain (2015). Clinical Training Visit in Metabolic and Nutritional Support of High Specialty, Regional Hospital "Adolfo López Mateos" Regional Hospital, Mexico City, Mexico. (2017). Nutritionist-Dietician, National University of Colombia, Bogota. (2010). Coordinator of the Clinical-Pediatric Nutrition course, University Hospital of Valle. (2015 - present) Postgraduate Professor of Clinical Pediatric Gastroenterology and Nutrition, University Hospital of Valle. (2015-2016). Tutor in Natural Health (2016 - present). Occasional Teacher with major in Clinical Nutrition. University of Buenos Aires (2018). Exceptional Merit Sheet. UNINI. 	<ul style="list-style-type: none"> Doctorate in Projects, Universidad Internacional Iberoamericana (Mexico), [Studying] 	<ul style="list-style-type: none"> Master in Naturopathic Sciences 	<ul style="list-style-type: none"> MN012- Nutrition in Common Diseases MN015- Massage, Reflexology and Kinesiology SN086 - Biological Perspective on Organ Dysfunction SN087 - Naturist Diet and Dietary Sensibility SN089 - Biological-Naturist Therapies for Common Diseases SN093 - Pulsed Magnetic Wave and Hyperthermia SN094- Anti-aging, Free Radical and Antioxidant Therapy SN098 - Kousmine Method SN099 - Colon Hydrotherapy SN101 - Constitutional Types in Naturopathy Master's Thesis
				Academic Load
				11
				Number of Subjects
11				

PROFESSORS RECRUITED UNDER CONDITIONS OF EXCEPTIONAL MERIT				
Professor	CV Summary	Doctorate	Program	Courses Taught
Dr. (c) Sandra Jarrín	<ul style="list-style-type: none"> Master in Biological-Naturist Studies, University of León, Spain (2010). Professional Career in Nutritionist and Dietetics, South Scientific University, Peru (2006). <i>International Baccalaureate Diploma Program</i>, College of Sir Isaac Newton, Peru (2000). Exceptional Merit Sheet. UNINI. 	<ul style="list-style-type: none"> Doctorate in Health Education, Universidad Internacional Iberoamericana in Mexico [in progress] 	<ul style="list-style-type: none"> Master in Naturopathic Sciences 	<ul style="list-style-type: none"> MN005- Homeopathic Basics and Principles MN006- Homeopathic Method Application MN007 - Medical Homeopathic Material MN018 - Schüssler Salts MN019- Supervised On-site Practices SN011 - Phytotherapy SN088 - Aromatherapy SN096- Orthomolecular Therapy and Trace Elements SN102 - Homeopathy and Homotoxicology SN104- Bach Flowers Master's Thesis
				Academic Load
				11
				Number of Subjects
				10

EXTRAORDINARY PROFESSORS				
Professor	CV Summary	Doctorate	Program	Courses Taught
Dr. Roberto Ruiz	<ul style="list-style-type: none"> Bachelor of Arts (Geography and History), History Section at the University of Cantabria, Spain, 1988. Has taught and has had administrative positions at Universities in Latin America, Spain and the United States. Rector, Vice Rector, Secretary General of the University, Dean and Academic Director. Has been a professor and associate professor at several universities where he has taught courses in History, Anthropology, Cultural Heritage and Archeology. 	<ul style="list-style-type: none"> Doctorate in Education University of Newport, US (Doctorate in Education Philosophy, PhD.) 2001. Doctorate in IE at the University of Spain, approved by the Minister of Education (national record for Doctoral degree 2010 / H05334 in 2010). 	<ul style="list-style-type: none"> Master in Strategic Management with a Specialty in Management Master in Strategic Management with a Specialty in Telecommunications Master in Strategic Management with a Specialty in Information Technology 	<ul style="list-style-type: none"> Master's Thesis
Dr. Santiago Tejedor	<ul style="list-style-type: none"> Bachelor's in Journalism by the Autonomous University of Barcelona (Spain). Master in Communication and Education at the University of Barcelona (Spain). 	<ul style="list-style-type: none"> Doctorate in Journalism by the Autonomous University of Barcelona (Spain). (2006) Dr. in Project Engineering at the Polytechnic University of Catalonia (Spain). (2010) 	<ul style="list-style-type: none"> Master in Strategic Management with a Specialty in Management Master in Strategic Management with a Specialty in Telecommunications Master in Strategic Management with a Specialty in Information Technology 	<ul style="list-style-type: none"> Master's Thesis

GLOSSARY

- **Evaluated (educational) Activity.** Qualified activity of a certain type that allows recognizing the proper use and/or mastery of a set of topics.
- **Subject.** A subject is a set of contents, assessed educational activities and theoretical-practical learning experiences, which objective is for the student to acquire the knowledge, skills, behaviors and attitudes in certain specific areas of knowledge from previously acquired others. The subject demands an effort from the student's part to achieve the objective expressed in terms of credits.

- **Printed Subject.** Set of chapters on the content of a subject that define a body of knowledge for a specific training. Sequence of chapters and evaluated activities.
- **Asynchronous.** None simultaneous or mismatched event.
- **Author.** Anyone who can prove that he or she owns a work, in whole or in part, receiving protection under copyright law.
- **Grade.** Quantitative value obtained after carrying out an evaluated activity. The rating can be any of the following qualitative values with their quantitative values:

Quantitative Values			Value Qualitative
0-10	Grade Point Average GPA.	%	
10-8.6	4.00 – 3.50.	100-90	A
8.5-7.0	3.49 – 2.50.	89-80	B
6.9-4.5	2.49 – 1.60.	79-70	C
4.4-4.0	1.59 – 0.80.	69-50	D
0	0.79 – 0.00.	49-0	F

The grade equivalences for the qualitative values are:

- A: Outstanding
- B: Good.
- C: Average.
- D: Below Average.
- F: Failed.
- T: Transferred.

All grades should be notified to the student and known before proceeding with the following evaluated activity.

- **Candidate.** person who is interested in the University's studies program.
- **Academic Load.** Measure relative to the effort a professor considers a student should carry out to study and pass their subject.
- **University Community.** Group of professors, students and staff.
- **Contents.** Subject study material.
- **Password.** Secret code for accessing a mechanism or certain computer functions.
- **Credit.** Quantitative unit to measure the academic work carried out by the student. One credit equals 15 hours of contract work and 30 hours of autonomous work when carrying out an academic period.
- **Professors.** University Personnel in any academic role.
- **Student.** Generic name associated to a person enrolled into a Studies Program.
- **Active Student.** Candidate who has accomplished the admissions requirements, is up-to-date on their academic, administrative and economic duties, and is studying the studies program.
- **Withdrawn student.** Active or partially withdrawn student who has been removed from the program for academic, administrative, economic or their own reasons.

- **Egressed student.** Active student who has completed all of their subjects but has not turned in their Thesis Work.
- **Graduated Student.** Thesis student who has successfully completed their studies program and has received their diploma.
- **Thesis student.** Egressed student who has handed in their Thesis Work.
- **Supervised Exams (*Proctoring*).** Exams supervised by the academic personnel using a web cam.
- **Staff.** Person hired by the University who fulfills the responsibilities as described by their post.
- **Student Identification (ID).** Each active student will have a unique identification code. This code will enable them access to their confidential information.
- **Module.** One or several printed subjects grouped into one body of knowledge.
- **Academic Period.** Time in which a students may begin and end one or several subjects. For example, trimesters, semesters, etc.
- **Plagiarism.** Use of another's work, ideas or words as if your own without explicitly giving credit where the information came from.
- **Study Program.** Defines the set of subjects, evaluated educational activities and learning experiences through which the student should manage the knowledge and skills development, attitudes and values, as expressed in the graduate profile, that enable them to obtain the corresponding professional or academic degree. The Studies Program should at least contain the list of mandatory subjects, their prerequisites and their organization within a net of progression or studies programming, and at least, the credit value of each subject, as well as the sum of the credits for each academic period or studies module.
- **Studies Schedule.** Sequence of subjects and evaluated activities. Every active student receives their own studies schedule when beginning their studies or continuing with them.
- **Synchronous.** Event that is done at the same time.
- **Evaluation Techniques.** Any activity that measures what the student has learned so as to give them a grade or offer them information on their academic achievements.
- **Volume.** Physical folder storing one or several printed parts of a subject delivered to active students as they progress through the studies program. It is a physical storage unit.
- **User.** Person who uses a computer and carries out several operations so as to learn.
- **Academic Life.** Academic Life is the time during which a student has an active status. The sum of the periods in which they are in this status should not be excluded to the duration of the studies program which they are studying. The Academic Life's maximum number is stipulated by the program's duration. Academic life is recorded as of the official date of enrollment at the University until the delivery date of the final work required for graduation.
- **University Life.** Space of time during which a student stays related to the University as part of the program upon a change in status. The Academic life is found within the University Life, but does not imply the student's graduation. University Life is recorded as of the official date of enrollment at the University until the delivery date of the final work required for graduation, or due to complete withdrawal by exceeding the program's period, any sanction applied or other motive.



APPENDIX:

Subject Description by Academic Department

INDEX

•• SUBJECT DESCRIPTION BY ACADEMIC DEPARTMENT

1. Department of Language and Communication Science	1
1.1. Doctorate in Education with a Specialty in Research	1
1.2. Master in Teaching Spanish as a Foreign Language	5
1.3. Master in Teaching English as a Foreign Language	7
1.4. Master in Education with a Specialization in Higher Education	11
1.5. Master in Education with a Specialty in the Organization and Management of Education Centers	14
1.6. Master in Education with a Specialty in Teacher Training	17
1.7. Master in Education with a Specialty in ICT in Education	21
2. Department of Innovation, Business and New Technologies	24
2.1. Master in Strategic Management with a Specialty in Management	24
2.2. Master in Strategic Management with a Specialty in Information Technology ..	43
2.3. Master in Strategic Management with a Specialty in Telecommunications	50
3. Department of Projects	56
3.1. Doctorate in Projects with a Specialty in Research	56
3.2. Master in Project Design, Administration and Management	60
3.3. Master in Project Design, Administration and Management with a Specialty in Architecture and Urban Planning	65
3.4. Master in Project Design, Administration and Management with a Specialty in Innovation and Product	69
4. Department of Environment and Sustainability	75
4.1. Master in Environmental Management and Auditing	75
5. Department of Health Sciences	88
5.1. Master in Physical Activity: Sports Training and Management	88
5.2. Master in Naturopathic Sciences – Acupuncture	92

SUBJECT DESCRIPTION BY ACADEMIC DEPARTMENT

1. DEPARTMENT OF LANGUAGE AND COMMUNICATION SCIENCE

1.A. DOCTORATE IN EDUCATION WITH A SPECIALTY IN RESEARCH

D0005 - Methodology of Scientific Research I. Foundations

Research is essential for doctoral students since it is essential that they acquire the basic training necessary to be able to write their doctoral thesis and do so with the highest possible quality. This subject presents the student with the basic concepts and foundations of research.

D00014 - Methodology of Scientific Research II. Paradigms and Methods

This subject presents the stages of the research methods within education, enabling the student to take a closer look at the scientific method, by which facilitating their contribution within their chosen field. The student will analyze the paradigms and research methods in education.

D0011- Research Seminar (Doctoral File)

This subject enables students to actively participate in a doctoral research seminar during which they will analyze and show the initial structure of the research work that they wish to develop. In order to do so, they will have to start consulting and reviewing specialized sources. The student will develop a research protocol (doctoral file), in which they will have to define a tentative topic.

FP117– Learning Theories and Methodological Approaches in Education

This subject offers the study and analysis of teacher training models that respond to quality mechanisms, as well as the knowledge of teaching methodologies to guide the teaching practice, and to construct teaching and learning processes that develops professional competencies. This subject presents the most complete training models, as well as the knowledge of teaching methods based on self-learning and collaborative learning, strategies that develop the personal and professional competencies necessary for the teaching profession. Students will conduct research to understand the structure of social phenomena and explain how they function and come to control and transform them, and will also develop learning methodologies for the classroom.

FP118 - Curricular Design and Programming

The competence that needs to be developed to plan teaching-learning scenarios has been considered one of the most fundamental teaching skills. This subject presents the current situation in curricular programming and design, as well as the basic concepts of curricular programming to help the student distinguish and define them. Studies linked to evaluative research and case studies are presented to ascertain the effects of teacher innovations on the methods followed within the teaching activity, adaptations of the curriculum and various components of the teaching program that vary with the diversity in the student body. The student will also develop teaching-learning programs by considering the paradigms of curricular research and applying different curricular theories.

FP119 – Learning Factors

This subject introduces the factors that influence teaching and learning in the classroom and the various learning strategies. The student will apply the models and theoretical frameworks in curricula that correspond to the problems of the information and knowledge society, the school, and the classroom. Students will conduct research to analyze the factors that determine learning processes, and academic performance as a consequence.

FP120 - Creation, Adaptation and Evaluation of Materials

Teaching materials are one of the most important tools for a teacher's pedagogical action. In this sense, this subject develops research components that contribute to educational innovation in the search to improve teaching and learning processes. Its research character integrates both quantitative and qualitative approaches to evaluate the quality of the teaching materials, identifying the benefits of their use in learning and facilitating decision-making on instructional design, producing teaching materials and implementing pedagogical models.

FP121 - Skills Development

This subject enables the student to distinguish between contents, objectives and competences. The student will understand the importance of competences in the organization of the teaching process and will apply said knowledge when organizing teaching processes based on competences, after carrying out research on learning as seen from different perspectives.

FP122 - Fundamentals of Special Education: Processes of Attention to Diversity

This subject studies the pedagogical and educational aspects of Special Education with the purpose of introducing students to the nature and foundations of this discipline through the analysis of the history of Special Education, current different educational concepts, knowledge of diversity assistance through legal provisions in force; educational planning in the curriculum and characterization of the specific needs of educational support associated with different disabilities and disorders.

FP123 - Educational Counseling and Mentoring

This subject presents the different concepts and models in guidance and psychopedagogy. The student will design and develop a Tutorial Action Plan where they will apply the knowledge acquired in class and through research, considering contexts, resources and tutorial functions, among others.

FP124 - Applied Didactics

This doctoral subject will: "*Applied Didactics*" is a reference for those teachers who, starting their career and educational research, learn how to carry out research in the field of Didactics. In this way, students will, as a consequence, implement this science within their teaching and learning processes. Students will acquire knowledge on the nature of Didactics for research and innovation. To integrate theory and practice in a cyclical and continuous process in which practice contributes to the theory of real situations that enable them to elaborate effective ways of addressing teaching, and the theories contributing to practicing the normativity and guidance to approach the processes mentioned according to the nature of Didactics.

FP125 - Physical Activity Applied to Education, Health and Performance

The contents of this subject are related to the fundamental physiological bases in understanding the adjustments and adaptation of the human body to physical exercise, the parameters that make up the prescription of physical exercise, the characteristics of exercise for improving cardiovascular endurance, and the correct assessment of "fitness", as well as the analysis of the starting points in the initiation and planning of all research in physical activity and the health sciences (discovery of the scientific problem, study variables, scientific explanation, the hypothesis, types of research, etc.) The main objectives of this course are related to the planning and development of research in the field of Physical Activity and Health, such as the fundamental principles of research planning, differentiating the types of research in this field, learning about the empirical research in the Physical Activity and Health Sciences, the application of procedures for the classification of scientific information to the research plan itself and the development of research plans as adapted to each subject. The predominant paradigm is the quantitative one, proving a wide commitment to everything surrounding experimental, quasi-experimental and correlational methods.

FP126 - ICT in Education and Learning Theories

In this subject, the study of the history of the media and didactic resources is proposed as a research work scheme, delving into the curricular and learning theories. Situated within a curricular approach, it delves into the research line on the teacher's knowledge in ICT, its application within the educational context and the processes generated by its integration within the different areas of work. Studies in this field have both quantitative and qualitative components, although a greater number of studies related to the former have been found, especially those referring to levels of mastery, use and satisfaction with the different tools and technological applications.

FP127 – Organization and Management of Educational Centers

The main contents of this subject are centered on said research that aims to show the reality of the centers from different points of view, prioritizing the curriculum and methodologies for evaluating centers and teachers within a social-critical paradigm, in which the results of the teaching activity and the organizational functioning of the centers prevail. It proceeds to analyze the configuration of the educational system, the school typology, the management function and its evolution, the management models of the centers, the types of responsibility exercised in educational management, the procedures for the admission of students and their influence on the center's life, the organization and participation of families in educational centers, as well as the organization and use of space and time.

D0006 - Research Work I

An important activity in the student's education within the doctoral program is to carry out a research work, which represents the application of the theoretical concepts learned with that of their own vision, and a research methodology applied within a defined line of work.

Once the student has completed and approved the general and core subjects in accordance with the evaluation system, they will carry out a research project supervised by the Thesis Director. This work will be carried out according to a specific line of research.

D0007 - Research Work II

Once the student has completed and approved the general and core subjects in accordance with the evaluation system, they will carry out a research project supervised by the Thesis Director. This work will be carried out according to a determined line of research and subsequent and/or related to Research Work I, according to the chosen line of research.

DD008 - Doctoral Thesis Proposal

Once the general and core subjects have been approved, as well as the supervised research work, the student will carry out and defend a proposal for a Doctoral Thesis, applying all their knowledge acquired up to that moment. This work will be supervised by the Thesis Director assigned by the Doctorate Director and according to a specific line of research.

DD009 - Doctoral Thesis Development

A doctoral thesis is an original research work written on a specific topic, and in this case, on a defined line of research supervised by the Thesis Director assigned by the Doctorates Director. The work must be individual and, above all, original, focusing on a topic of scientific research in the area of education and deriving from a line of research in accordance with social, economic and technological development.

DD010 - Doctoral Thesis Dissertation

The scientific dissertation is a written work aimed at a presentation on reasoning, in this case, of the results obtained and systematized from the previously carried out doctoral research work, which will subsequently be presented orally. This will be carried out through a doctoral degree exam that will be supported according to the mechanics described for the Doctoral Thesis Project. The doctoral student will request the defense of their doctoral thesis before a board authorized by the Doctoral Commission.

Once the student has passed this exam, they will complete the credits established in the program and be awarded the degree of *Doctor in Education with a Specialty in Research*.

The dissertation of the Doctoral Thesis is part of the program's educational activities, since it evaluates the results obtained in the research within quantitative and qualitative aspects from a defined hypotheses; the methodological criteria used to carry it out, its applicability, as well as the synthesis, writing and communication skills by the doctoral candidate. This last part is essential for the doctoral candidate's formation in their specialty in research.

1.B. MASTER IN TEACHING SPANISH AS A FOREIGN LANGUAGE

FP017 - Modes of Directing the Classroom

Identification of the basic features of classroom management such as the classroom language, the way to correct work, group work and the use of L1 (first language). Analysis of the current theories on education in groups with diverse capabilities and on discipline in the classroom. The course covers in detail an important task of the teacher: contemplation in action. (3 credits)

FP018 - Observation and Research in the Classroom

The most influential forms of traditional research and philosophy of knowledge that sustains them. Current approaches to research in the classroom as, for example, the thesis that all observation is elective and is a cultural construction. This subject provides a solid foundation of knowledge and techniques which allows us to focus on the Memory and the Research Project. (3 credits)

FP019 - Second Language Acquisition

Main models of second language acquisition and their influence in the classroom. It takes into account the acquisition of first languages and shows the parallels between both processes. The analysis of the influence of context in acquisition of second languages. Incentives on the considerations of factors that may affect the acquisition of the language on the part of the students in the actual context of the classroom which the professor directs. (3 credits)

FP020 - Individual Factors in Learning

All classrooms are formed by groups of individuals, and each one of them has a vital experience, some linguistic patterns, an emotional and intellectual development and a style of learning. Recent research emphasizes the role of individual factors in the language development of the student. This subject investigates the cognitive, affective, physical and psychological factors that influence a learning individual, and critically examines concepts such as intelligence, aptitude, motivation and personality. (3 credits)

FP021 - Learning Factors

Analysis of the current research work in the field of learning strategies and ways to encourage students to develop them. Classification of the various learning strategies and their relationship with the current trends in textbooks. (3 credits)

FP022 – Communication and Pragmalinguistic Proficiency

Communication as an animal and human phenomenon. Communicative functions. Components: participants, context, code. The communication process as a model of interaction. Basic Pragmatic concepts and sociolinguistic appropriateness. (3 credits)

FP023 – Language, Culture and Bilingualism

Language and culture: factors of the cultural component. Historical Perspective. Interculturality. Intercultural Communication. Contrastive Analysis: methodology. Bilingualism:

psycholinguistic aspects, language. Bilingualism and education. Educational policy and programs of bilingual education. (3 credits)

FP038 - Spanish Grammar for SFL professors

The role of grammar in the Spanish as a Foreign Language classroom. Basic topics on grammar for Spanish as a Foreign Language professors: the present and past indicative, the future and the conditional, the imperative, the subjunctive, the indirect style, to be and being, and personal pronouns. (3 credits)

FP025 - Spanish and its Varieties

The current situation of Spanish in the Hispanic world: unity and diversity. Spanish or Castilian: terminological issues? Characterization of the social varieties of Spanish. Description of its varieties and sociocultural contexts. Exemplary Spanish as a model for the teaching of Spanish as a second language. (3 credits)

FP026 – Teaching Vocabulary

About the words: some fundamental notions of lexicology: the lexical unit, their relationships, and structure. What words to teach: “fundamental” lexicon, “meteorite” words, levels and records. How to teach those words: play with the lexicon; assess and correct them. More than words: idiomatic expressions. Use of the dictionary in the teaching of Spanish as a foreign language. Other media: cinema, television, songs, the Internet. (3 credits)

FP027 - Methodological

Main methodological approaches in the teaching of languages and its historical evolution: the methods of Grammar translation, Audio-lingual and Direct. It discusses the modern approaches such as the humanities, communicative, lexicon and focuses on the student, with the concept of method being discussed in detail. (3 credits)

FP028 - Developing Skills in the Classroom

Detailed analysis of the different approaches in the teaching of the macro-skills based on listening comprehension, reading, and oral and written expression. The current research on these skills and the evaluation of various classroom activities and teaching techniques to develop the use of Spanish language in the students. (3 credits)

FP029 - Creation, Adaptation and Evaluation of Materials and Resources

Evaluation of the materials for the teaching of Spanish (textbooks and supplementary materials) that are currently used. Their qualities and defects in relation to the characteristics of each context and the curriculum design. Principles for evaluating materials and priorities in its application. Process of creating, testing and reviewing materials in the specific contexts of education. (3 credits)

FP030 - Educational Technology in Language Learning

Ways to use information technology for the development of the four linguistic skills and the relationship of technology with teaching methods. The implications of computer use as a learning tool. The evaluation of the software, including innovations in multimedia software and Internet applications, is encouraged. (3 credits)

FP031 - Projects and Tasks

Education based on projects and tasks (e.g. Homework). Examination of a learning-task structure and its components. Structuring of a teaching unit based on tasks. Criteria for the evaluation of tasks and the current debate on the need to focus on the form of the tasks being evaluated. Implication analysis of the task-based education in the curriculum design and programming, especially in the context of work in projects. (3 credits)

FP032 - Evaluation of the Learning Language Process

Evaluation Fundamentals: formal and informal assessment; language learning; phases and components of the evaluation. Central Issues: what to assess: prospective, perfective and perfect variables; to whom; when; for whom (audiences). Ways to assess: observation, test. Criteria for assessing the instruments. Data collection. Data analysis. Conclusions and proposals. (3 credits)

FP033 - Curriculum Design and Programming: Theory and Practice

Curriculum design of the language. Curriculum Design of Spanish as a foreign language. Analysis of the situation and the setting of objectives: at the ministerial level, at the international level (the curriculum of the Instituto Cervantes), at the local level. Programming: methodology at all three levels. Evaluation. (3 credits)

FP034 - Practicum

Although the Practicum and the Final Draft are collected separately in the program, both are two different phases of the same process that culminates in the presentation of a single work. Broadly speaking, the process consists in the student selecting a topic of study that specially interests them, and proceeding to the creation of a monographic work. The Practicum part would correspond to the phase of the study, analysis, or design field. (5 credits)

TFC

The work may have a character applicable for the classroom, professionalized (for example, professors in training who want to perfect their teaching experience) or on research (for example, especially interesting for professors in training that which to dedicate themselves to academic research on applied linguistics aspects in the Spanish as a Foreign Language didactic field). It can also be a combination of both elective modules. (10 credits)

1.C. MASTER IN TEACHING ENGLISH AS A FOREIGN LANGUAGE

This program is only offered in English.

FP003 - Second language acquisition

This subject introduces the main models of second language acquisition and explores their implications for classroom teaching. First language acquisition is also considered and similarities are drawn between the two processes. The influence of context on second language acquisition is explored, and students are encouraged to reflect on the factors, which may affect the language acquisition. (3 credits)

FP005 - Teaching Pronunciation

This subject provides a formal introduction to phonetics and phonology in English. Aspects of phonology such as stress, intonation and sounds are examined in some detail. Current debates over teaching phonology are reviewed, as well as the practical implications for the teaching of pronunciation in the classroom. (3 credits)

FP004 - Individual Factors in the Learner's Development

All classrooms are made up of groups of individuals each with their own life experience, patterns of language, emotional and intellectual development, and learning styles. Recently, research has put emphasis on the role of individual factors in the learner's language development. This subject looks at the cognitive, affective, physical and psychological factors, which influence the individual's language learning. Constructs such as intelligence, aptitude, motivation and personality are critically examined. (3 credits)

FP002 - Observation and Research in the Language Classroom

This subject introduces the major research traditions and the views of knowledge that underpin them. Current approaches to classroom research, for example the assumption that all observation is selective and culturally constructed. This subject provides a solid base of knowledge and techniques for the Practicum and Final Project. (3 credits)

FP001 - Approaches to Language in the Classroom Context

This subject provides an introduction to the most important current psycholinguistic and sociolinguistic theories. We examine how perceptions towards the nature of learner language have changed over the last few decades. The concept of interlanguage is explored in depth, and research into classroom interaction is critically reviewed. We also look at the role of input in language learning, and the current psycholinguistic notions of "noticing" and "restructuring". (3 credits)

FP037 - Content & Language Integrated Learning

CLIL (Content & Language Integrated Learning) looks like a good candidate for the next revolution in language teaching, although its growing tentacles reach out into other areas of the curriculum and force us to consider more seriously the role of content, how we define that content, how we choose it and how we can teach it more effectively. CLIL also raises interesting questions about the relationship between language and cognition that are too often neglected at classroom level. This subject looks at its brief history, its theoretical bases, and how it might represent the future of language teaching. (3 credits)

FP006 - Methodological Approaches

This subject covers the main methodological approaches in ELT. Methods such as Grammar-Translation, the Audio-lingual Method and the Direct Method etc. are reviewed historically. Contemporary approaches such as humanistic, communicative, lexical and learner-centred approaches are discussed, and the notion of “method” is analysed in depth. (3 credits)

FP008 - Developing Language Skills in the Classroom

This subject looks in detail at approaches to the teaching of macro skills of listening, speaking, reading and writing in ELT. It presents current views based on recent research of these skills, and the teaching of grammar and vocabulary. A range of practical classroom activities and teaching techniques for developing learners’ use of the language are evaluated. (3 credits)

FP009 - Materials and Resources in EFL - Design, Creation, Adaptation and Evaluation

This subject includes an examination of EFL materials (textbooks and supplementary materials) that are currently used in the profession, and explores their strengths and weaknesses in relation to features of context and curricula. Principles of materials evaluation are identified and prioritised. The process of materials design, creation, trial and error in specific teachings contexts is highlighted. (3 credits)

FP007 - Classroom Management - Techniques and Reflections on Practice

This subject identifies some of the key features of management in classrooms, such as classroom discussion, corrective feedback, group work and the use of L1. Current views on teaching skills and discipline are also covered. The important area of teachers’ beliefs, known as ‘teaching thinking’, is covered thoroughly. (3 credits)

FP010 - Computer Assisted Language Learning

This subject introduces students to the ways in which computer software can be used to develop learners' language skills and examines how CALL relates to teaching methodologies. Students will study the issues involved in using computers to assist language learning. Students will also evaluate software, including developments in multimedia software and Internet applications. (3 credits)

FP036 - Teaching English Through Translation

This subject, written by the University of Vigo, starts with a brief history of translation as an introduction to how translation can be used in the EFL classroom. The differences between teaching translation as a subject per se and as a tool in the teaching of a foreign language are also explored, and different approaches to how translation can be used to enhance the learning process, even in communicative classrooms, are considered. (3 credits)

FP011 - Tasks and Projects

This subject presents an approach to teaching structured around tasks and projects. We examine the structure of a learning task, its components, and the effective sequencing of different types of tasks within units of work (teaching units). The criteria for the evaluation of tasks, and the current debate on

the need to focus on task methods. Students will also analyze the implications of task-based teaching for syllabus and curriculum design, specifically in the context of project work. (3 credits)

FP014 - Learning Strategies

This subject examines research into learning strategies, and considers how we can encourage our students to develop these further. It also presents the taxonomies of learning strategies and the current learning strategies trends in ELT course books. (3 credits)

FP013 - English in the Community

This subject on sociolinguistics looks at the social and cultural context in which language is situated and in which it is learned. The global position of English will be explored to gain a better understanding of its future status. Students will examine how gender and race affect language use, as well as the notion of language shift. Important current issues such as the social implications of bilingualism are also explored. (3 credits)

FP012 - Assessment and Testing in the Classroom

This subject looks at the purposes of assessment and describes current practices and trends in assessment and evaluation in ELT. The fundamental principles of evaluation, and its formal and informal approaches. (3 credits)

FP015 - Curriculum and Course Design - Principles and Practice

This subject looks at models of curriculum and course design, and their planning, implementation and evaluation in different national contexts. Two main paradigms of curricula are presented, and the principles of syllabus design are examined in depth. An outline of the most significant syllabus types is provided. (3 credits)

FP034 - Practicum

Even if it seems that the Practicum and the Research Project are not related, they are two different stages of one project. Broadly speaking, the process consists of choosing a topic in which the student is interested and doing a monographic project on it. The Practicum in the work field camp and the analysis and design is the research. (5 credits)

TFC

This project can be a practical piece of research (e.g. teachers that want to improve their teaching methodology), a theoretical one (e.g. teachers that want to research into applied linguistics in the TELF field) or, even, a combination of both. (10 credits)

1.D. MASTER IN EDUCATION WITH A SPECIALIZATION IN HIGHER EDUCATION

FP101- Learning Theories and Methodological Approaches in Education

This subject offers the study and analysis of teacher training models that respond to quality mechanisms, as well as the knowledge of teaching methodologies to guide the teaching practice, and to construct teaching and learning processes that develops professional competencies. (3 credits)

FP102- Strategic Learning and Professional Development

This material contains some statements related to reflexive learning, understood as life learning that is genuine, relevant and necessary.

It was developed based on the idea of offering teachers in training the learning opportunities needed to develop the provisions and expertise that will enable them to act as agents of change and leaders of a reform in the institutions in which they work. (3 credits)

FP087- Learning Factors

This subject has the purpose of improving the performance in educational scenarios. It relies in the search for answers to questions such as, what must be transferred, why, what for and how it is achieved. (3 credits)

FP079- Tutoring Action in the Education System

The tutorial action is a very important part of teaching, not only because it is legally established, but because today more than ever the attention to people and group related issues are of vital importance. The social reality that surrounds the school exposes these issues through different problems that affect education, for example, coexistence, personal relations o equal opportunity. (3 credits)

FP077- ICT in the Classroom. Educational Applications and Use of Resources

Currently, the education system, demands for professionals trained in Information and Communication Technologies (ICT), as we are immersed in a new society of knowledge.

This society, is mainly characterized by a limited access to information, but not all information produces knowledge. Education professionals are ideal for the transformation of this knowledge for their students. (3 credits)

FP078- Interculturality and Education

This subject covers the different perspectives of immigrants to the educational institutions. First, the subject covers the social changes of immigration, as the population movements cause relentlessly the relation among cultures. That is exposed indistinctly at a personal level, and in the customs and language. The problem relies in the fact that the cultural codes that are to far from our own are very complex to understand. (3 credits)

FP080- Conflict Solution and Transformation in the Educational Environment

This subject offers elements for understanding a global coexistence model in the educational institutions as paradigm capable of transforming the elements of the current educational system.

The student will be able to acquire a theoretical-practical vision of the different tools that are used in the various processes of conflict resolution in school; communication skills, negotiation processes, school mediation, the informal mediation within the classroom, the “mouth-ear” corner, class conference and positive discipline. In this way, the subject provides the student with knowledge about the development of conflict resolution, mediation and positive discipline in the field of coexistence and conflict transformation in education. (3 credits)

FP084 – Environmental Education in Formal Education

From a practical approach, this subject deals with the day-to-day as a way of making education for teachers, facilitating the incorporation of environmental content in basic education, not neglecting that it allows the development of the human being in a holistic manner.

The subject has the intention of training professionals capable of designing, promoting and directing environmental education processes for sustainable development, in different fields of the social activity from global, regional and local point of views. The structure is centered in four action fields: conceptual and philosophical bases, environmental education for sustainability, environmental management and finally national and local experiences. (3 credits)

FP103- Fundamentals of Special Education: Processes of Attention to Diversity

This course studies the pedagogical and educational aspects of Special Education with the purpose of introducing students to the nature and foundations of this discipline, through the analysis of the history of Special Education, current different educational concepts, knowledge of diversity assistance through legal provisions in force; educational planning in the curriculum and characterization of the specific needs of educational support associated with different disabilities and disorders. (3 credits)

FP104- Organization and Management of Educational Centers

This subject contributes to establish the professor’s pedagogical or psycho-pedagogical profile, considering as main function to design and intervene in the educational action. As a scientific discourse, must adhere to science patterns (content systematization, work methods, proper methodology, etc.). Therefore, from the beginning it is necessary to know and understand its concepts, principles, structures, terminology, etc. However, it has a more practical character, as the theory emerges from the educational practice and the regulations in force. (3 credits)

FP105 - Portfolio I

The Portfolio is a teaching tool or learning instrument which main objective is to motivate reflection for more competent professionals. In this case, of educational professionals. (1 credit)

FP092- Methodology of Scientific Research

This subject presents the stages of the research process and its techniques, so that the student takes a closer look at the scientific method, and so ease their contribution within their chosen field. (3 credits)

FP173 - Educational Quality, Evaluation and Innovation in Higher Education

This subject contains aspects of quality management and its importance for education and factors that favor educational quality, including training, leadership and developing guidance within higher education.

It also deals with the different models of quality assessment in programs, teachers and educational centers, as well as innovation, planning and educational quality. (3 credits)

FP171 - Educational Modalities in the University Context: Face-to-face, Blended and Distance

Among the topics addressed in the subject are both the face-to-face modality in the university B-learning model, as well as semi-present Mentoring and the MOOCs distance modality. (3 credits)

FP176 - Professional Development and Reflective Practice of University Professors

This subject aims to emphasize teaching improvement programs, as well as professional development and educational change.

Another point of improvement is the action-research topic as an innovation to its practice within the university. (3 credits)

FP179 - Teaching Methodologies and Strategies in the University Classroom

In this subject, different methodologies and strategies and their importance in the university classroom are described. Among them, it is worth mentioning project and problem based learning, which the student actively learns the knowledge and skills through the approach of a problem or complex situation.

Service-learning and cooperative learning are of the utmost pedagogical concern and are of social benefit. They combine learning and community service processes in a single well-articulated project, in which participants are trained by getting involved in the real needs of the environment with the aim of improving it.

Other methodologies addressed in this subject are mentoring, role-playing, gaming, inverted classes and PLE through mobile and ubiquitous learning. (2 credits)

FP180- Learning Assessment in the University Context

The topics addressed in this subject are the conceptual framework on the assessment of learning, as well as the different approaches and trends in assessment: assessment by competencies

The subject also addresses the importance of Quality and procedures for the assessment of learning and evidence of learning, assessment techniques and tools. (2 credits)

FP108 - Portfolio II

The Portfolio is a teaching tool or learning instrument which main objective is to motivate reflection for more competent professionals. In this case, of educational professionals. (1 credit)

FP116 - Portfolio III

The Portfolio is a teaching tool or learning instrument which main objective is to motivate reflection for more competent professionals. In this case, of educational professionals. (2 credits)

FPEE01 - Master Thesis

The work may have a character applicable for the classroom, professionalized (for example, professors in training who want to perfect their teaching experience) or on research (for example, especially interesting for professors in training that which to dedicate themselves to academic research on applied linguistics aspects in the Spanish as a Foreign Language didactic field). It can also be a combination of both elective modules. (10 credits)

1.E. MASTER IN EDUCATION WITH A SPECIALTY IN THE ORGANIZATION AND MANAGEMENT OF EDUCATION CENTERS

FP101 - Learning Theories and Methodological Approaches in Education

This subject offers the study and analysis of teacher training models that respond to quality mechanisms, as well as the knowledge of teaching methodologies to guide the teaching practice, and to construct teaching and learning processes that develops professional competencies. (3 credits)

FP102- Strategic Learning and Professional Development

This material contains some statements related to reflexive learning, understood as life learning that is genuine, relevant and necessary.

It was developed based on the idea of offering teachers in training the learning opportunities needed to develop the provisions and expertise that will enable them to act as agents of change and leaders of a reform in the institutions in which they work. (3 credits)

FP087- Learning Factors

This subject has the purpose of improving the performance in educational scenarios. It relies in the search for answers to questions such as, what must be transferred, why, what for and how it is achieved. (3 credits)

FP079- Tutoring Action in the Education System

The tutorial action is a very important part of teaching, not only because it is legally established, but because today more than ever the attention to people and group related issues are of vital importance. The social reality that surrounds the school exposes these issues through different problems that affect education, for example, coexistence, personal relations o equal opportunity.
(3 credits)

FP077- ICT in the Classroom. Educational Applications and Use of Resources

Currently, the education system, demands for professionals trained in Information and Communication Technologies (ICT), as we are immersed in a new society of knowledge.

This society, is mainly characterized by a limited access to information, but not all information produces knowledge. Education professionals are ideal for the transformation of this knowledge for their students. (3 credits)

FP078- Interculturality and Education

This subject covers the different perspectives of immigrants to the educational institutions. First, the subject covers the social changes of immigration, as the population movements cause relentlessly the relation among cultures. That is exposed indistinctly at a personal level, and in the customs and language. The problem relies in the fact that the cultural codes that are to far from our own are very complex to understand. (3 credits)

FP080- Conflict Solution and Transformation in the Educational Environment

This subject offers elements for understanding a global coexistence model in the educational institutions as paradigm capable of transforming the elements of the current educational system.

The student will be able to acquire a theoretical-practical vision of the different tools that are used in the various processes of conflict resolution in school; communication skills, negotiation processes, school mediation, the informal mediation within the classroom, the “mouth-ear” corner, class conference and positive discipline. In this way, the subject provides the student with knowledge about the development of conflict resolution, mediation and positive discipline in the field of coexistence and conflict transformation in education. (3 credits)

FP084 – Environmental Education in Formal Education

From a practical approach, this subject deals with the day-to-day as a way of making education for teachers, facilitating the incorporation of environmental content in basic education, not neglecting that it allows the development of the human being in a holistic manner.

The subject has the intention of training professionals capable of designing, promoting and directing environmental education processes for sustainable development, in different fields of the social activity from global, regional and local point of views. The structure is centered in four action fields: conceptual and philosophical bases, environmental education for sustainability, environmental management and finally national and local experiences. (3 credits)

FP103 - Fundamentals of Special Education: Processes of Attention to Diversity

This course studies the pedagogical and educational aspects of Special Education with the purpose of introducing students to the nature and foundations of this discipline, through the analysis of the history of Special Education, current different educational concepts, knowledge of diversity assistance through legal provisions in force; educational planning in the curriculum and characterization of the specific needs of educational support associated with different disabilities and disorders. (3 credits)

FP104- Organization and Management of Educational Centers

This subject contributes to establish the professor's pedagogical or psycho-pedagogical profile, considering as main function to design and intervene in the educational action. As a scientific discourse, must adhere to science patterns (content systematization, work methods, proper methodology, etc.). Therefore, from the beginning it is necessary to know and understand its concepts, principles, structures, terminology, etc. However, it has a more practical character, as the theory emerges from the educational practice and the regulations in force. (3 credits)

FP105 - Portfolio I

The Portfolio is a teaching tool or learning instrument which main objective is to motivate reflection for more competent professionals. In this case, of educational professionals. (1 credit)

FP092- Methodology of Scientific Research

This subject presents the stages of the research process and its techniques, so that the student takes a closer look at the scientific method, and so ease their contribution within their chosen field. (3 credits)

FP108 - Portfolio II

The Portfolio is a teaching tool or learning instrument which main objective is to motivate reflection for more competent professionals. In this case, of educational professionals. (1 credit)

FP081 - Strategic Planning and Management

This subject was designed for those who manage educational organizations or who prepare for these functions in the future. This subject helps people who lead teams to grow and be trained in current education aspects. (3 credits)

FP082 - Planning and Management of Projects

How to solve a problem is the mission of any project. But solving the problem in an efficient and effective manner requires that who directs the project with a work team, structures the task and use mental schemes and strategies which, on one hand, facilitate the systematic and systemic resolution of the problem and in addition guarantee continuous improvement of the activities developed for future projects.

With the purpose of learning concepts, strategies and techniques necessary for the professional management of any project, this course presents and delves into the planning and programming processes of the different phases that make up a project. In concrete, this subject brings the meaning, nature and scope that these two processes have for the design, implementation and successful end of all projects. (3 credits)

FP113 - E-Business and its Integrations in the Corporative Systems for the Educational Management

This subject brings the fundamentals of corporative integration in education through 4 systems (ERP, RRHH, SCM and CRM) and the respective technologies. The students studies the systems and revise the technology available to reach full integration that allows business competitiveness, despite the size, locations or its operation size. (3 credits)

FP114 - Educational Quality. Evaluation and Innovation

This subject offers the student the theoretical and practical knowledge necessary to evaluate and manage quality in educational institutions. Thus, influences in the importance of knowing the factors that determine this quality (positive and negative) and the characteristics of efficient organizations. (2 credits)

FP115 - Work Team Management Techniques

The management and leadership topic has been of interest since man emergence, when man relied on the consultant, witch of the “cacique”. In these modern times they are called administrators, executives, directors, managers and leaders. Nowadays, in Century XXI, with globalization and a changing world, the phenomenon is still studied due to its implications in the economic, business, political sphere and in other spheres of social life. (2 credits)

FP116 - Portfolio III

The Portfolio is a teaching tool or learning instrument which main objective is to motivate reflection for more competent professionals. In this case, of educational professionals. (2 credits)

1.F. MASTER IN EDUCATION WITH A SPECIALTY IN TEACHER TRAINING

FP101 - Learning Theories and Methodological Approaches in Education

This subject offers the study and analysis of teacher training models that respond to quality mechanisms, as well as the knowledge of teaching methodologies to guide the teaching practice, and to construct teaching and learning processes that develops professional competencies. (3 credits)

FP102- Strategic Learning and Professional Development

This material contains some statements related to reflexive learning, understood as life learning that is genuine, relevant and necessary. It was developed based on the idea of offering teachers in training the learning opportunities needed to develop the provisions and expertise that will enable them to act as agents of change and leaders of a reform in the institutions in which they work. (3 credits)

FP087- Learning Factors

This subject has the purpose of improving the performance in educational scenarios. It relies in the search for answers to questions such as, what must be transferred, why, what for and how it is achieved. (3 credits)

FP079- Tutoring Action in the Education System

The tutorial action is a very important part of teaching, not only because it is legally established, but because today more than ever the attention to people and group related issues are of vital importance. The social reality that surrounds the school exposes these issues through different problems that affect education, for example, coexistence, personal relations o equal opportunity. (3 credits)

FP077- ICT in the Classroom. Educational Applications and Use of Resources

Currently, the education system, demands for professionals trained in Information and Communication Technologies (ICT), as we are immersed in a new society of knowledge. This society, is mainly characterized by a limited access to information, but not all information produces knowledge. Education professionals are ideal for the transformation of this knowledge for their students. (3 credits)

FP078- Interculturality and Education

This subject covers the different perspectives of immigrants to the educational institutions. First, the subject covers the social changes of immigration, as the population movements cause relentlessly the relation among cultures. That is exposed indistinctly at a personal level, and in the customs and language. The problem relies in the fact that the cultural codes that are to far from our own are very complex to understand. (3 credits)

FP080- Conflict Solution and Transformation in the Educational Environment

This subject offers elements for understanding a global coexistence model in the educational institutions as paradigm capable of transforming the elements of the current educational system. The student will be able to acquire a theoretical-practical vision of the different tools that are used in the various processes of conflict resolution in school; communication skills, negotiation processes, school mediation, the informal mediation within the classroom, the “mouth-ear” corner, class conference and positive discipline. In this way, the subject provides the student with knowledge about the development of conflict resolution, mediation and positive discipline in the field of coexistence and conflict transformation in education. (3 credits)

FP084 – Environmental Education in Formal Education

From a practical approach, this subject deals with the day-to-day as a way of making education for teachers, facilitating the incorporation of environmental content in basic education, not neglecting that it allows the development of the human being in a holistic manner.

The subject has the intention of training professionals capable of designing, promoting and directing environmental education processes for sustainable development, in different fields of the social

activity from global, regional and local point of views. The structure is centered in four action fields: conceptual and philosophical bases, environmental education for sustainability, environmental management and finally national and local experiences. (3 credits)

FP103 - Fundamentals of Special Education: Processes of Attention to Diversity

This course studies the pedagogical and educational aspects of Special Education with the purpose of introducing students to the nature and foundations of this discipline, through the analysis of the history of Special Education, current different educational concepts, knowledge of diversity assistance through legal provisions in force; educational planning in the curriculum and characterization of the specific needs of educational support associated with different disabilities and disorders. (3 credits)

FP104- Organization and Management of Educational Centers

This subject contributes to establish the professor's pedagogical or psycho-pedagogical profile, considering as main function to design and intervene in the educational action. As a scientific discourse, must adhere to science patterns (content systematization, work methods, proper methodology, etc.). Therefore, from the beginning it is necessary to know and understand its concepts, principles, structures, terminology, etc. However, it has a more practical character, as the theory emerges from the educational practice and the regulations in force. (3 credits).

FP105 - Portfolio I

The Portfolio is a teaching tool or learning instrument which main objective is to motivate reflection for more competent professionals. In this case, of educational professionals. (1 credit)

FP092- Methodology of Scientific Research

This subject presents the stages of the research process and its techniques, so that the student takes a closer look at the scientific method, and so ease their contribution within their chosen field. (3 credits)

FP106- Curricular Design, Programming and Outcome Development

The development of necessary competencies to plan teaching-learning competences is considered one of the most important teaching competences.

This consideration has had more force in the last years due to the new role that the new educational laws has offered to the teachers. From the point of view of the current legal regulations, the teacher is not only a professional who should be limited to training programs prepared from the Administration, but that they should specify the general lines emanating from the current curricular decrees to implement teaching proposals. Therefore, if the class planning has always been necessary, currently it is basic and necessary. (3 credits)

FP090- Learning Evaluation

Evaluation is one of the curriculum elements and is unanimously recognized as such by most. Evaluation is, therefore, an issue that must be considered in the teaching planning, as well as in any

curricular project. Curriculum and evaluation stick together and it is not conceivable to understand one and not refer to the other. (3 credits)

FP107 – Classroom learning methodologies

To talk about educational methodology supposes to search answers about how to teach, in other words, structure teaching/learning activities where the students are going to participate to reach the proposed outcomes with the content selected, through an intentional, systematic and planned action. (3 credits)

FP088 - Creation, adaptation and evaluation of materials

The teaching resources support the contents and allow application of learning-teaching techniques. The fact that they have an impact in the outcomes its selection, adaptation and development requires adequate techno-pedagogical knowledge. Teaching resources are mediators between the individual and reality. Besides impacting directly the motivation and climate created in the different teaching contexts. (2 credits)

FP091- Content and Language Integrated Learning

This subject offers the new perspectives of the CLIL approach , to enable the students analysis of its own strengths and possible weaknesses, moreover, evaluate the possibilities of the teaching approach for the XXI Century. (2 credits)

FP108 - Portfolio II

The Portfolio is a teaching tool or learning instrument which main objective is to motivate reflection for more competent professionals. In this case, of educational professionals. (1 credit)

FP116 - Portfolio III

The Portfolio is a teaching tool or learning instrument which main objective is to motivate reflection for more competent professionals. In this case, of educational professionals. (2 credits)

FPEE01 - Master Thesis

The work may have a character applicable for the classroom, professionalized (for example, professors in training who want to perfect their teaching experience) or on research (for example, especially interesting for professors in training that which to dedicate themselves to academic research on applied linguistics aspects in the Spanish as a Foreign Language didactic field). It can also be a combination of both elective modules. (10 credits)

1.G. MASTER IN EDUCATION WITH A SPECIALTY IN ICT IN EDUCATION

FP101 - Learning Theories and Methodological Approaches in Education

This subject offers the study and analysis of teacher training models that respond to quality mechanisms, as well as the knowledge of teaching methodologies to guide the teaching practice, and to construct teaching and learning processes that develops professional competencies. (3 credits)

FP102- Strategic Learning and Professional Development

This material contains some statements related to reflexive learning, understood as life learning that is genuine, relevant and necessary.

It was developed based on the idea of offering teachers in training the learning opportunities needed to develop the provisions and expertise that will enable them to act as agents of change and leaders of a reform in the institutions in which they work. (3 credits)

FP087- Learning Factors

This subject has the purpose of improving the performance in educational scenarios. It relies in the search for answers to questions such as, what must be transferred, why, what for and how it is achieved. (3 credits)

FP079- Tutoring Action in the Education System

The tutorial action is a very important part of teaching, not only because it is legally established, but because today more than ever the attention to people and group related issues are of vital importance. The social reality that surrounds the school exposes these issues through different problems that affect education, for example, coexistence, personal relations o equal opportunity. (3 credits)

FP077- ICT in the Classroom. Educational Applications and Use of Resources

Currently, the education system, demands for professionals trained in Information and Communication Technologies (ICT), as we are immersed in a new society of knowledge.

This society, is mainly characterized by a limited access to information, but not all information produces knowledge. Education professionals are ideal for the transformation of this knowledge for their students. (3 credits)

FP078- Interculturality and Education

This subject covers the different perspectives of immigrants to the educational institutions. First, the subject covers the social changes of immigration, as the population movements cause relentlessly the relation among cultures. That is exposed indistinctly at a personal level, and in the customs and language.

The problem relies in the fact that the cultural codes that are to far from our own are very complex to understand. (3 credits)

FP080- Conflict Solution and Transformation in the Educational Environment

This subject offers elements for understanding a global coexistence model in the educational institutions as paradigm capable of transforming the elements of the current educational system.

The student will be able to acquire a theoretical-practical vision of the different tools that are used in the various processes of conflict resolution in school; communication skills, negotiation processes, school mediation, the informal mediation within the classroom, the “mouth-ear” corner, class conference and positive discipline. In this way, the subject provides the student with knowledge about the development of conflict resolution, mediation and positive discipline in the field of coexistence and conflict transformation in education. (3 credits)

FP084 – Environmental Education in Formal Education

From a practical approach, this subject deals with the day-to-day as a way of making education for teachers, facilitating the incorporation of environmental content in basic education, not neglecting that it allows the development of the human being in a holistic manner.

The subject has the intention of training professionals capable of designing, promoting and directing environmental education processes for sustainable development, in different fields of the social activity from global, regional and local point of views. The structure is centered in four action fields: conceptual and philosophical bases, environmental education for sustainability, environmental management and finally national and local experiences. (3 credits)

FP103 - Fundamentals of Special Education: Processes of Attention to Diversity

This course studies the pedagogical and educational aspects of Special Education with the purpose of introducing students to the nature and foundations of this discipline, through the analysis of the history of Special Education, current different educational concepts, knowledge of diversity assistance through legal provisions in force; educational planning in the curriculum and characterization of the specific needs of educational support associated with different disabilities and disorders. (3 credits)

FP104- Organization and Management of Educational Centers

This subject contributes to establish the professor’s pedagogical or psycho-pedagogical profile, considering as main function to design and intervene in the educational action. As a scientific discourse, must adhere to science patterns (content systematization, work methods, proper methodology, etc.). Therefore, from the beginning it is necessary to know and understand its concepts, principles, structures, terminology, etc. However, it has a more practical character, as the theory emerges from the educational practice and the regulations in force. (3 credits).

FP105 - Portfolio I

The Portfolio is a teaching tool or learning instrument which main objective is to motivate reflection for more competent professionals. In this case, of educational professionals. (1 credit)

FP092- Methodology of Scientific Research

This subject presents the stages of the research process and its techniques, so that the student takes a closer look at the scientific method, and so ease their contribution within their chosen field.

(3 credits)

FP108 - Portfolio II

The Portfolio is a teaching tool or learning instrument which main objective is to motivate reflection for more competent professionals. In this case, of educational professionals. (1 credit)

FP109 - ICT in Education and Learning Theories

This subject presents different key aspects of e-learning contextualization in the current educational situation and regarding the main learning theories. The subject is mainly conceptual, where the student can distinguish the different concepts of distance education that exist. (3 credits)

FP111- Analysis of Technological Resources and Design of Creative Activities

This subject mainly has a practical character that consists in offering students technological resources criteria and elements of analysis, and presents student real creative activity cases to train them in this sense. (3 credits)

FP110- Training in Virtual Learning Environments

Today is unlikely that an educational institution does not include in its offer, in addition to courses, blended learning or on line distance education. In fact, not doing so can suppose being at the margin of new socio-educational future challenges . (3 credits)

FP076 - Collaborative Work in Virtual Environments

This subject, in one hand introduces the student to the concepts, technologies, solutions and tools for collaborative work in virtual environments and helps them understand the meaning and nature of working in collaborative and cooperation spaces, with support or not of systems and technology and information communication. In the other hand, it allows to have a general overview of the social-work context of collaborative work, technologies, and solutions and the tools to support this context through computer assistance. (2 credits)

FP112- Design and Evaluation of Training Proposals Based on ICT

This subject is mainly practical and consists in the exposition of different real cases in diverse contexts: virtual / blended learning and classroom training with the use of ICT.

Currently being unable to go beyond what is related with a restricted context of action involves a degree of vulnerability that can lead to the exclusion of the Network Society (Momino, J. M; Sigalã@s, C; Meneses,J., 2008). The globalized world in which we live in, mediated by all kinds of technologies and systems that enable us access to information and communication beyond our context, entails a complexity that is difficult to overcome due to ethnocentric positions and limited to conceptions restricted to the locality, or to the usual skills and competences. This fact is the substance that causes

communities with little opening or few resources for this, to become affected by new forms of digital exclusion due to gaps in skills and abilities to actively operate in a global context. (2 credits)

FP116 - Portfolio III

The Portfolio is a teaching tool or learning instrument which main objective is to motivate reflection for more competent professionals. In this case, of educational professionals. (2 credits)

2. DEPARTMENT OF INNOVATION, BUSINESS AND NEW TECHNOLOGIES

2.A. MASTER IN STRATEGIC MANAGEMENT WITH A SPECIALTY IN MANAGEMENT

TR026 - Business Administration and Management

This subject introduces the student to the concepts and techniques of administration and business management. It covers topics from organizational theories, until the new organizational forms in the new economy, whether for service companies, technology companies, SMES and family businesses. (3 credits)

DD002 - Management and Cost Control

This subject is considered an introductory course for the area. Fundamental concepts of accounting are studied here, to then focus on the essential issues of management and cost controls.

The subject allows you to understand the role of information in organizations through the generation and analysis of budgets understood as the foundation of management processes and strategic planning. (2 credits)

TR047 - Financial Management

The subject highlights the most significant aspects that conceptually shape the financial direction of any company. (3 credits)

DD004 - Marketing

This subject is directed toward understanding the operation of marketing and sales in a company, introducing the concepts and techniques of marketing and business management, and to understand the meaning, nature and scope of the marketing function. (3 credits)

DD152 - Economy

It is a very necessary subject to understand the macro-economic factors that influence family enterprises and dominate aspects related to the economic theory such as consumption, inflation, demand and the GDP. (2 credits)

DD118 - Basic Statistics

This course gives the student the knowledge of basic descriptive statistics, probability and statistical inference concepts, from an eminently practical point of view. (2 credits)

DD120 - Financial Mathematics

This subject introduces the student to the phenomenon of financial assessment, especially through the assessment laws used in the practice. (1 credit)

DD124 - Management Accounting

The objective of this subject is to provide the student with a sound knowledge of the internal accounts of a company that allows them to develop its application. It will begin by defining the content of Management Accounting and its interrelationship with Financial Accounting. We will discuss the problems related to the classification, location, and the allocation of costs that allow obtaining production costs. Subsequently, using the calculated cost as a base, it will be used to guide the rational decision-making in the company to enable the efficient utilization of productive resources. (2 credits)

TR046 - Strategic Management of Human Resources

This subject is aimed at designing the conceptual and methodological framework for recognizing the systemic and strategic approach of the current Human Resources Management (HRM). (2 credits)

DD040 - Negotiation and Conflict Resolution Techniques

This subject contains information to help us understand the theoretical and practical aspects related to conflict and the most common resolution strategies: Negotiation, Mediation and Arbitration, among others. (2 credits)

DD032 - Performance Evaluation and Management by Competencies

This course explains the need to resort to specific theoretical-methodological budgets to be inserted in the skill focus of the HRM practices, to resort to the training process as the only sustainable way to maintain and revitalize these skills and their development, and use the performance appraisal process as feedback for the revitalization and development of the aforementioned labor skills. (2 credits)

TR024 - Management Techniques and Organizational Leadership

The overall objective of this subject is to know and to deepen knowledge in the styles of leadership and management, their relationship, differences, importance and theoretical approaches, as well as the competencies and skills necessary for their exercise. (2 credits)

DD090 - Business Ethics and Corporate Social Responsibilities

This subject provides the main concepts for the student to master the importance and validity of Business Ethics and Corporate Social Responsibility, recognizing them as an effective tool for achieving competitiveness. After studying the three chapters, the student will understand the concept of ethics and social responsibility, its validity and universal character, as well as the ethical standards and their relationship with business efficiency. They will also master the relationship between business ethics, values, competitiveness, efficiency and effectiveness, and will be able to establish the ways and actions necessary for the company (and/or the company's leadership) to have an ethical and responsible behavior. (3 credits)

DD041 - Work Team Management Techniques

This subject shows the theoretical and practical elements about groups and teams, their characteristics, techniques and the tools for their effective management. (2 credits)

DD076 - Management Without Distances

The subject introduces the concepts and techniques of e-Management, explaining the meaning, nature and scope of the management and administration of projects and businesses without distance. (1 credit)

DD026 - Collaborative Work in Virtual Environments

This subject teaches the concept and the technologies associated with collaborative work from the point of view of the management of organizational teams up to the management of distance teams mediated by virtual environments. (1 credit)

DD042 - Time Management and Conducting Meetings

This subject is fundamental in order to learn how to optimize meetings in work through good preparation and the development of the same. It also provides criteria and techniques for time management within the framework of the directive function. (2 credits)

DD043 - Stress and Burnout

Teaches you how to manage situations of stress and burnout within a business organization, giving the student the necessary theoretical and practical knowledge. (2 credits)

DD044 - Public Speaking Techniques

Develops the participants' capacities to prepare and deliver professional presentations for the achievement of the desired impact in the auditorium. (1 credit)

IP082 - Quality Management: ISO 9001

After an introduction to the connotations of the term "quality", the subject is in a general way, the process of certification based on ISO 9001, since the adoption of the commitment after the introduction on the part of Management, up to being awarded the certificate. There is also a chapter devoted to quality certification in the software. (3 credits)

IP092- ISO 45001

It delves into the fundamental concepts on occupational risk prevention and the ultimate consequences of occupational accidents and diseases on people and business economics. In addition, it defines what is meant by system management and lays the basis for the implementation of a management system for the prevention of occupational hazards based on ISO 45001. (2 credits)

MA098 - Business Environmental Management. ISO 14001

Describes Environmental Management Systems (EMS) as a tool aimed at organizing and formalizing procedures for a company that takes into consideration the environmental aspects of all their activities. It also sets out, in a didactic and clear way, the steps required for implementing said environmental management instrument, aimed at environmental protection and the reduction of barriers to international trade. (3 credits)

DD012 - Operations Management and Administration

This course will deal with the activities included in the management of operations and logistics from the more strategic aspects linked to the long term decisions as the design and product definition (what do we offer?) and the design and analysis of the process (how do we get?), passing through medium and short- term tactical decisions and operational planning activities (how much, how and where do we offer it?), with the unquestionable support of the logistical tasks that make this a viable plan. In this sense, the logistics is studied as a way to provide a timely response to the requirements at the lowest possible cost. (2 credits)

DD013 - Logistics

This subject will allow you to get to know and understand the concept of logistics operations within the organization to master the management of acquisition, movement, and storage of products, and inventory control, and the information associated with all of them. (2 credits)

DD014 - Strategic Management and Planning

This course facilitates strategic thinking and provides training in the tools and mechanisms to facilitate management by accepting the contemporary management of change as something final within environments that are unstable and the variables surrounding organizations. (3 credits)

TR038 - Planning and Management of Projects

This subject is operational in nature and seeks to provide the tools to develop an operational plan from a strategic plan. (3 credits)

TI013 - Engineering, Strategy and Management of ICT Systems

This subject will include the organizational role of ICTS, from its strategic repositioning within organizational reengineering, until its strategic management as a business resource. (3 credits)

TI025 - e-Business and its Integration with Corporate Management Systems

This subject explores the concept and notion of business integration through information by reviewing the integration from the organizational and technological aspect, and the essential concepts of integration based on ICT such as ERP, SCM and CRM. (3 credits)

TI017 - Integration of Business Management Systems

This subject gives a wide and extensive view of the concept and notion of business integration through information by reviewing the integration from the organizational and technological aspect, and the essential concepts of integration based on ICT such as ERP, SCM and CRM. (5 credits)

DD162 - Marketing Strategy Development

Considered one of the major parts of this area, this course focuses on obtaining a complete vision of the various marketing aspects from the perspective of the company's strategy. The subject generates the patterns needed to know how to concentrate organizational resources for greater opportunities and achieve a sustainable competitive advantage as well. (2 credits)

TI030 - Network Security and Management

The subject prepares to use the proper tool, in every circumstance, to perform an optimum and safe management of networks. Within the correct operation, identifying the risks of information and the assurance of the system are of vital importance. (3 credits)

TI011 - Society of Change and Information.

This course will develop a vision that contextualizes the management of the cultural and technological change, providing the foundations and approaches for the transit to the Information and Knowledge Society and their organizational implications in business management. (3 credits)

DD068 - Knowledge Management and Organizational Learning

This subject presents the methodologies, tools and techniques associated with the management of knowledge and sets out in said way to achieve a sustainable strategy of organizational learning from the maturity models of knowledge management. (2 credits)

TI004/DD163 - International Commerce and Marketing

Provides a broad view of the main tools and knowledge to help face international projections along with the concepts and strategies of foreign markets, and so be able to actively participate in the business world at the international level. (4 credits)

TI014 - Trade and E-marketing

This subject shows and deepens two essential issues which are very much interlinked: electronic commerce (shown from its conceptual foundations until the technological ones) and new forms of marketing (shown from its foundations up to the change produced by the ICTs and give rise to marketing in computing environment). The subject concludes with a methodology that proposes a marketing strategy within the space of electronic commerce. (4 credits)

TI023 - Study and Case Resolution (I, II and III)

The objective is to present a complete document that shows a total development of a case. It can be theoretical or applied, but always following the related doctrines, theories and disciplines.

The case faces the student with the effective comprehension of the knowledge, and requires the student to solve a real world or simulated problem. We recommend that it is started at the end of the last subject, because at this time the student will have the necessary resources to develop it quickly and methodically. (10 credits)

DD073 - Organizational Leadership and Coaching

Among the contents addressed in the subject, we can find the following:

Leadership philosophy and talent development, leadership styles, competencies and skills of the leader and manager, transformational leadership as well as inspirational leadership and antithesis of leadership. The subject explains in detail what the powers and values of leadership and emotional intelligence in the company consist of.

Coaching and mentoring, and the stages and coaching as a leadership style are another of the topics developed in this subject.

DD159 - Introduction to the New Marketing

It discloses the theoretical and ideological foundations of marketing and the difference between the strategic and operational ideas, taking into account the new tasks that marketing plays in a market economy. (2 credits)

DD160 - Market Research

Highlights the importance of information and the treatment thereof, providing a practical overview of modern information systems and presenting decision making in the field of marketing and market research techniques. (2 credits)

DD161 - Consumer-Buyer Behavior

This subject helps understanding the nature and diversity of customer's needs (consumer and industrial levels), and motivational factors that play a role in the consumer's mind at the time to "respond" to a stimulus caused by marketing. (2 credits)

DD164 - Relational Marketing

This course appreciates the issues that support the marketing and strategies relating to the “external and internal world” of the company in order to maintain long-term relationships so as to establish the necessary points for the correct management of the group itself. (2 credits)

DD165 - Marketing Audits

It provides the student with the tools and techniques for conducting audits, emphasizing the role of the auditor and the basics in the auditing process. (1 credit)

DD166 - Product and Brand Policy Management

It introduces the student to the realm of strategic decision making on the factors that make the product a key element of the supply market. (3 credits)

DD167 - Price Management Policy

This course focuses specifically on the design of strategies and programs as a variable cost of generating revenue. (3 credits)

DD168 - Distribution Management Policies

This subject studies the different strategic decisions that can be made in terms of logistic channels, in order to have the best distribution method. (3 credits)

DD169 - Communication Management Policies

This subject leads to understanding the point of view of the receiver as a basis for further strategic actions to spread the message, so as to inform about the handling of the management of publicity programs, sales promotion and public relations. (3 credits)

DD170 - Marketing Services

It offers a comprehensive overview of the marketing services, so that the student is updated on the issue and may consider different approaches, tools and instruments that could be useful in the marketing work. (2 credits)

DD171 - Control and Marketing Plan

It highlights the strategic importance of a marketing plan with a methodological proposal for structure. (2 credits)

DD153 - Financial Valuation for IAS

The International Accounting Standards bring with them the obligation to apply different standards of financial rating to carry out a good accountancy. Students will learn to properly apply these assessment rules in a practical way, using Excel as a tool. (2 credits)

DD122 - International Accounting Standards

The subject introduces the student to the International Accounting Standards Board of the IASB, its philosophy and its main applications. (4.5 credits)

DD121 - International Taxation and Financing

This subject is intended for students to learn how to determine the optimal type of tool for their financing needs and explain the tax issues affecting multinational companies. (1.5 credits)

DD123 - Financial Statement Analysis

In this subject, students will acquire sufficient knowledge so that, through the accounting information and methodology, they are able to make a diagnosis about the economic and financial situation of the company and its future projection. (2 credits)

DD128 - Administration and Planning of Audits

This subject familiarizes the student with the usual concepts of auditing, introducing the generally accepted standards of auditing and a basic outline of the phases that compose it. The usual methods of audit planning and management, starting from the time that the client requests the order to the development of the audit program, are presented. Lastly, the concept of internal control is presented, the evaluation of the same and the preparation of the memorandum for internal control. (1 credit)

DD154 - Internal Control

This subject focuses the student to develop an overall audit plan and to understand and write any document that is integrated in the working papers. Also, to determine the tasks depending on the execution time of the work. (2 credits)

DD155 - Documentation, Tests and Risks

Any performance from the auditor should always be thoroughly documented. The set of records generated by an audit, and based on which the auditor will express their opinion on the report, popularly called "working papers." Students will learn how to document the work in each execution time of the audit. (2 credits)

DD130 - Auditing Procedures by Area

This course focuses on providing knowledge about how to conduct an audit work in different areas after the planned audit procedure. It gives the student the foundations to perform the audit work in different areas, as once the audit procedure is planned, the auditor divides his/her review of the annual accounts in different areas, to facilitate understanding and recording tasks. The auditor must know the accounting rules applicable to him/her in each area, to determine the work's objectives and discern the main points of internal control to be checked, so as to establish the necessary audit procedures. (5 credits)

DD131 - Audit Reports

The ultimate purpose of this course is the correct preparation of a report that highlights the accuracy or otherwise the data collected in the annual accounts. But before doing the report, it is important that the auditor be assured that the work has been carried out correctly: hence the importance of a good system of quality control. (1 credit)

DD119 - Statistical Sampling

This course provides students with the practical knowledge of the different sampling methods available for auditing professionals, as well as procedures for the selection and determination of sample sizes. (2 credits)

DD125 - Total Quality Costs

This course conveys the student a number of essential skills to institutionalize measurements on the quality levels and none quality in any company through quality cost systems that suit their needs. (2 credits)

DD126 - Budget and Public Accounting

This course seeks to provide students with updated knowledge and the basic tools of public economics which enable them to recognize and describe the basic economic mechanisms of the market and the way, in which through it, the decisions of economic agents are coordinated. (3 credits)

TR043 - Tourism Foundations

It is an introduction to tourism. Historical development of tourism. Tourism in the XXI century. The behavior and motivation of the tourist. The model of the travel and tourism industry from a business perspective. The aviation business. Maritime transport. The rail and road transportation. The hosting service. Tour operators. Travel agents. Auxiliary travel services. Organizations and associations related to travel and tourism. The environmental and social impacts of tourism. (3 credits)

TR037 - ICT in the Tourism Industry

This subject studies the transformation of society, where the emergence of the New Technologies of Information is analyzed. In this context, the characteristics of this revolution are analyzed, without forgetting the general framework in which the travel industry and tourism moves. For its development and presentation, the text has been supplemented with studies, reports, research papers, etc.

TR022 - Hotel Business Management

In this course the general lines of the hospitality industry, developments and trends in the tourism sector are plotted. These issues will be analyzed from a global perspective with local and international references. The role of the client and their influence on the decisions of the professionals in the last decade are also important. (4.5 credits)

TR023 - Food and Drinks Management

In this course different culinary offerings shall be classified or be organized in five large families. Examples of independent hotels and restaurants that host these offers and explain its operation will be provided. (4.5 credits)

TR027 - Cultural Heritage and Tourism

After discussing the concept of culture and identifying the different types of existing assets today, the economic, social and political impacts exerted on the rural and urban heritage are analyzed, not forgetting everything about the techniques of conservation and bibliographic and documentary restoration. (3 credits)

TR008 - The Territory as a Tourism Resource

In this course the characteristics of tourism under the geographical point of view is presented in a concise manner, from the theory of touristic space to development models, through real space tourism, indicators and natural, cultural and ethnic factors of tourism activity. (3 credits)

TR028 - Environmental Impact on Tourism Activities

After defining a series of previous environmental concepts, this subject deals with the social and environmental impacts caused by tourism activities on the environment, through a series of sustainability indicators. Likewise, some basics about the different methods of economic assessment of damage to the environment and the methodology for conducting an environmental impact are provided. (3 credits)

TR030 - Rural Tourism and Sustainable Development

It is known that increasing the influence of tourism in towns and rustic and natural interior areas, is a perfectly predictable phenomenon, either because the increased interest is generated as an "escape" to the increasing saturation of the coastal zone, or from the rural tourism and within a growing contingent of people. In this course the threats posed by the absence of a definition of the tourism function are analyzed, and development strategies of rural areas as a business opportunities in Europe and Latin America to stop these imbalances, economic costs and proposed guidelines to develop a business plan in the context of sustainable development, are also discussed. (3 credits)

TR031 - Alternative Tourism and Ecotourism

An overview of the new tourism environment is presented in this course, in what refers to the alternatives of conventional tourism: the creation of new tourism products, and the trends and characteristics of the new consumer. (3 credits)

TR036 - Strategy and Tourism Businesses on the Internet

This course is offered in order to present new concepts based on cases and compile, in a relatively comprehensive way, part of the vast and extensive experience in the use of Internet in the tourism market and on the digitization and virtualization of tourism enterprises with an approach to trade and e-business. (3 credits)

TI049 - Quantitative Analysis of Tourism

The interpretation of decisions under uncertainty and, in general, of the various sciences, depends largely on statistical methods.

Statistics help corroborate a hypothesis by providing mathematical support to the observations made. This course addresses the need to justify business decisions based on the information provided by data that, too often, is scarce. It is therefore a compendium of techniques for the collection and presentation of information, confidence intervals, hypothesis testing and prediction. (4 credits)

DD108 - Family Business Concepts and Characteristics

This subject presents the characteristics and the forms of family business organizations. It shows the coexistence of family values and business values and their impact on the company. It analyzes the mechanisms that generate harmony and potential sources of conflict in families. (2 credits)

DD109 - Succession and Continuity in Family Business

This course addresses the need for a succession plan to ensure the continuity of family businesses, and understand not only the preparation of the successor but of the entire organization to this process. Among other subjects are the Succession Plan, Continuity and Preparing Successors, when to Initiate the Succession, Analysis of Succession Options and the Succession Planning Process. (2 credits)

DD110 - Systematic Focus Applied to Conflict in Family Businesses

This subject addresses the psychological and emotional aspects within the family business that are natural causes of conflict within its members and influencing both family dynamics and everyday family business, specifically in decision-making. (2 credits)

DD111 - Professionalization of Family Business

It displays the issue of professionalism in family businesses and the professional insertion of processes in family firms. It also presents the fundamental so that outside professionals are motivated within the family businesses. (2 credits)

DD112 - Governing Structures and Bodies

The objective of this course is that the student learns about the various bodies of government in family businesses: board of directors, shareholders, family assembly, family council, advisory board, etc. It also presents the characteristics, composition, power, skills and functions of each body. (2 credits)

DD113 - The Family Protocol

This subject presents the potential conflicts that may exist in family firms and studies the process of preparing the family protocol and their effects, as an instrument to promote agreements and covenants on property, family and business. (2 credits)

DD114 - Property Management in Family Businesses

This subject is a required course for the various forms of compensation that may be perceived by management shareholders and non-management shareholders, and to understand the process of stock valuation and profitability. It also teaches different types of property organization in family businesses. (1 credit)

DD115 - Key Factors for Success in the Family Business

This subject analyzes issues and common characteristics that lead to successful centenarian family businesses, through the presentation of successful cases. (1 credit)

DD116 - Creation and Internationalization of Family Businesses

Provides knowledge and the needed tools to define a competitive strategy and create a company that is positioned in the targeted market as appropriate. It analyzes those factors that influence the international positioning of a family business in order to have the ability to establish and conduct an international development plan adapting themselves to the different cultures and markets. (2 credits)

DD143 - Basic Legal Aspects of the Family Business

The subject provides an overview of the legal aspects that are essential when creating a family business. In order to give continuity to the business and avoid its extinction, the managers need to know and adjust the legal and tax aspects of their business, as established in each countries trade codes. (3 credits)

IP059 - Fundamentals in Occupational Risk Prevention

It delves into the fundamental concepts on occupational risk prevention and the ultimate consequences of occupational accidents and diseases on people and business economics. (2 credits)

IP060 - Occupational Safety

Some key factors are provided on the importance of preventing occupational accidents and encouraging safety. (4 credits)

IP003 - Industrial Hygiene

Learning how to identify, evaluating and controlling environmental factors that may affect the worker's health. (5 credits)

IP062 - Ergonomics

A study of the set of techniques that addresses the worker's adequacy, adjustment and adaptation through the design and conception of jobs. (3 credits)

IP071 - Applied Psychology

Examines the internal and external pressures caused by psychosocial factors, the hazards or risk factors linked to the employee's mental burden. (2 credits)

IP078 - Background and Actual Situation of Integrated Management

Changing management philosophy is described with respect to what existed a few years ago, in order to do a review of the most important concepts seen before and that will be the basis to address the following chapters. In this sense, the topic is seen from a different point of view, addressing quality as being understood as product quality, occupational quality and environmental quality. (3 credits)

IP9001 - Introduction and Fundamentals of Integrated Management Systems

This subject provides the foundations of integrated management systems: quality, environment and occupational risk prevention, providing ideas on the implications over organizational behavior in reference to the integration, and in turn, on the integration project over the human factor. (2 credits)

IP9002 - Advantages and Difficulties of The Integration of Systems, Grades, Modes and Integration System Models

The agents involved in the integration of systems, the scope and the advantages and disadvantages of the implementation are presented. It expounds on the Agents involved in system integrations. Elements of an integrated management system. Advantages and disadvantages of system integrations. Levels of integration. (3 credits)

IP9003 - Integration of Management Systems Based on Standards and Processes

The most important initiatives on integration, founded on a single standard, are discussed based on standard models and their matches, and finally, the formula most accepted today, which is the process management. (2 credits)

IP9004 - Implementation of the Integrated Management System

This subject develops a case study for integration by processes of the quality, environment and occupational risk prevention management systems, in a company for recycling of used oil. (2 credits)

IP051 - Water Management: Basic Principles

The treatment of physical, chemical and biological water purification based on their characterization, and their most important uses for domestic, industrial and/or agricultural purposes are identified and their reusability under current legislation is studied. (5 credits)

IP052 - Basic Waste Management

The guidelines established by the legislation in the integrated management of solid waste, waste minimization, good industry practices and associated environmental issues are studied. (3 credits)

IP053 - Atmospheric Contamination Treatment

The prevention and control of atmospheric emissions from industrial and transport activities, in view of the fulfillment of the Kyoto Protocol are discussed. (5 credits)

IP054 - Treatment of Contaminated Soils

The characteristics of contaminated soil as a result of human activities are studied, and preventive and corrective measures for their recovery as well. (4 credits)

IP002 - Workplace Safety

The subject delves into those aspects that require a planned action of prevention, including the information and training of workers, leading to a better understanding of both the real extent of risks arising from work as to how to prevent and avoid them. The safety of specific sectors, such as the handling of gases and pressure vessels, machine safety principles, soldering techniques, laboratory work, electrical hazards, and hazardous waste management, among other operations are exposed. This course meets the new demands, providing criteria, rigor and, above all, common sense, when it comes to transposing the policy on health and safety organization. (7 credits)

IP076 - Workplace Hygiene

This subject allows you to know and understand, first, the theoretical, conceptual and historical foundations involved in the management of prevention and, secondly its organizational, social and technological implementation. The goal is for students to gain a global view of the activities planned in prevention that every company should follow in order to have a better knowledge of both the real extent of the risks of occupational diseases and the form to prevent and avoid them. This course is structured as a coherent pedagogical order. Each is divided into basic thematic units or chapters, which the contents should be studied to satisfactorily answer the various assessment activities. (7 credits)

IP073 - Ergonomics and Applied Psychology

Ergonomics and Applied Psychology helps to train competent professionals to carry out planned actions of prevention, with respect to working conditions that can affect the health of people who occupy a certain position.

This subject allows you to know and understand, first, the theoretical, conceptual and historical foundations involved in the management of prevention and, secondly its organizational, social and technological implementation. The goal is for students to gain a global view of the activities planned in prevention that every company should follow in order to have a better knowledge of the real extent of the risks arising from the work environment and its influence on people. This is done to achieve comfortable working conditions that do not physically, mentally, and socially harm the worker and which allow the development of the individual through their work. (7 credits)

IP064 - Training and Communication

In this subject there are techniques created over the risks arising from the use of work equipment, prevention and protection, information brochures and through participation and consultation.
(1 credit)

IP004 - Occupational Health

Occupational health is studied as a preventive tool that attempts to humanize the work, adapting the work to the man and avoid how many risks there are at work that may damage the health of workers.
(2 credits)

DD1004 - Health Economics

This course covers the macroeconomic factors that influence health. It displays aspects of economic theory, such as consumption, health expenditure, health supply and demand and relevant aspects of finance. (5 credits)

DD1007 - Health Planning

This course seeks to understand and assume with responsibility, changes in the environment, and continuously improve the quality of processes and management systems, for it is essential that the group fully understand that the overall program strategy is to define and achieve the laid out goals. This subject will include the appropriate use of health indicators for the analysis of the situation of the organization and then perform the appropriate health planning. (4 credits)

DD1008 - Health Services Management

This subject seeks to know and understand the different trends and approaches to the healthcare management environment, giving the students the tools needed to conduct an effective process in control. In addition, students will be trained to implement or evaluate an integrated management control within their organization's health system. (3 credits)

DD1009 - Health Marketing

This subject seeks to learn and recognize the health service as a company, since from it, greater efficiency and effectiveness will be achieved in the results. It is necessary to know and understand the characteristics of the production of health services and know how to establish criteria to measure hospital products. It is necessary that the professional that performs management within a healthcare organization is clear about what marketing tools may be useful for achieving the objectives. (3 credits)

DD1010 - Assistance Quality and Patient Safety

This subject seeks to know and understand the most important concepts and components of quality and safety in healthcare organizations. Clear about the importance of the professional's daily work within healthcare for the purpose of providing health services to the best possible standards. This subject provides them with the necessary and relevant information to understand the responsibility of the system to provide services which inevitably entails risks. (4 credits)

DD1012 - Health Economics

This course seeks to study the policies and different models governing sanitary health systems worldwide. The student will understand the importance of these systems and the number of people needed to run and respond to the needs of the population. Students also learn how to diagnose a health system; learn to recognize its components, particularly with regard to primary care, which is a cornerstone for the effective solution of the population's health problems. (4 credits)

DD1013 - Clinical Epidemiology

This course seeks to introduce students to evidence-based medicine; meaning that decisions are taken based on the health situation to help prioritize the daily work of healthcare facilities. Students will learn the basics of epidemiology, its uses and different methods and research designs that will allow decision making based on the current reality of the population it serves. (5 credits)

DD1014 - Biostatistics

This subject seeks to provide students the necessary tools for the collection, analysis and interpretation of data, which will enable the student to understand and carry out scientific research valid for a given population. It will help the realization of their thesis project and future research in which they wish to participate. It will also permit appropriate decision making in the managerial position that they assume in their healthcare establishment. (5 credits)

DD022 - Organizational Structure and Change

This subject shows the process of transformation that has a place in actual orientations, and analyses future tendencies that should be confronted. (2 credits)

DD024 - Organizational Culture and Setting

The subject analyzes the most relevant concepts and theoretical approaches representative of organizational culture and its climate, their relationship, the types and methods of study, as well as how to face and solve dysfunctions. (2 credits)

DD030 - Position Analysis, Description and Value

Analyze the advantages and disadvantages that can involve a description, analysis and job evaluation in the organization, following the most common methodologies and managing the process from start to finish. (2 credits)

DD031 - Recruitment, Selection and Promotion

This course shows the selection processes in the business and social environment, and more effective methods and tools for designing and programming its processing stages, observing the ratios and indicators commonly used in modern business. (2 credits)

DD034 - Training and Career Plans

It trains students in developing a training policy that allows the development of their organization's human potential and achieve strategic business objectives while meeting the requirements of current quality certifications and to develop tools and procedures to strengthen the organization's talent. (2 credits)

DD033 - Compensations and Incentives

This subject shows the student how to use compensation as a management tool integrated in HR policies and the strategies of the company. (2 credits)

DD036 - Human Resources Auditing

It provides the student with the tools and techniques for conducting audits, emphasizing the role of the auditor and the basics in the auditing process. (1 credit)

DD039 - Interpersonal Communication Technique

This subject identifies the elements involved in a communication process, lists these elements and describes the roles of the different people that are a part of the communication process in a workspace. (1 credit)

DD045 - Emotional Intelligence

Aims to understand that within human nature, not only does rational intelligence play a dominant role within the individual's and business's success, but certain emotions, both primary and secondary key competencies are developed for the understanding of humans between themselves and the way they react to different situations within business environments. (1 credit)

DD046 - Personal Marketing

This subject demonstrates the necessity of personal marketing in today's world. (1 credit)

DD047 - Intellectual Capital

This course is aimed at demonstrating that the human factor, as a creator and disseminator of knowledge, is becoming one of the main sources of competitive advantages for organizations. (1 credit)

DD048 - Quality as a Management Tool for Human Resources

It explores the importance of quality as an essential tool in HR managing. (1 credit)

DD049 - Neurolinguistic Programming

It introduces the student to an attractive, practical and highly topical subject. It also shows the patterns of human behavior by which some individuals and professionals in particular get the maximum development of excellence, while others, seemingly doing the same, do not. (1 credit)

DD091/DD092 - Conflict Theory

This topic introduces the basic theoretical pillars of the discipline in conflict resolution. From the outset, the student acquires a different conception of the conflict and its escalation and de-escalation dynamics, and develops their abilities to analyze conflicts in-depth prior to any intervention. It also delves into the psychological aspects of conflict and negotiation-mediation. The student will acquire knowledge of the theories and psychological mechanisms that act behind the negotiation- mediation processes. We also show the model of game theory on conflict and negotiation-mediation.

(5 credits)

DD093/DD094 - Emotion, Communication and Conflict

In this subject, the biological foundations of emotion, emotional self-awareness, emotional self-control, self-motivation, recognition of others' emotions and interpersonal relationships is studied, as well as the use of emotional intelligence in organizations. The student must acquire a broad understanding of the processes of conflict and negotiation in the context of organizational theory. Also, one must learn some of the skills and necessary knowledge to manage conflict while maintaining communication in the organizational context as in other environments. (4 credits)

DD138 - Conflict Resolution/Transformation Principles and Processes

In this course, the student will learn to distinguish between the processes in conflict resolution and other processes to resolve conflicts, but that cannot be understood as our own discipline (arbitration). In addition, the student will meet and practice solving processes/conflict transformation that is used in large and small groups. They will learn to work with conflicts when multiple parties are involved, associated or not, so as to drive decision-making processes in groups. They will work with such diverse processes as mediation in large groups, facilitating and appreciative dialog. (5 credits)

DD097/DD098 - Mediation

It aims to clarify the concept of mediation and the role of the mediator from a perspective that allows them to be differentiated from other methods. It also presents the mediation intervention from a technical perspective that gives coherence to a practice based on a model and an acting method.

(4 credits)

DD099 - National and International Legislation about Mediation and Other Conflict Resolution Procedures

The subject discloses the so-called Alternatives to Dispute Resolution (ADR or MARC) and the regulatory framework in which they are being implemented in America and Europe, with particular emphasis on mediation. (3 credits)

DD100- Conflict Solution and Transformation in the Educational Environment

It provides the necessary knowledge and skills to intervene in the process of improving coexistence and conflict transformation in schools. (2 credits)

DD101 - Conflict Resolution/Transformation in the Family

A description and processes analysis of conflict resolution and transformation within a family context that requires the intervention of third party opinions that facilitate dialog, responsibility and decision-making among the key-players of each situation. The material presented is the result of professional experience in conflict intervention, related to the breakdown of the couple (separation/divorce, custody, relationships with children, economic needs, etc.) and to those conflicts of intergenerational cohabitation, placement or organizational conflicts when referring to the needs of any of the persons constituting the family (elderly, disabled, mental illness, etc.). (2 credits)

DD102 - Resolution/Transformation of Conflict in the Community

This subject helps us to understand the conceptual framework of Community Mediation and develops the skills, competences and attitudes for exercising mediation in said environment. (2 credits)

DD103 - Conflict Resolution/Transformation in the Organization

It helps to understand the conceptual framework of the Mediation Community and develops the skills, competencies and attitudes to practice mediation in this area. (2 credits)

DD104 - Conflict Resolution/Transformation in the Criminal Field

This course shows the Reconstructive and Restorative Justice as a transformative paradigm of the penal and penitentiary systems. It provides a theoretical and practical view from the area compared to the various tools of Restorative Justice: mediation, conferences, circles, etc. The most important experiences of Restorative Justice in the European Union, the USA, Canada and Latin America are analyzed. (2 credits)

DD105 - Resolution/Transformation of Conflict in the Health Field

The purpose of this course is for students to consolidate a conceptual and practical formation that enables them to act as mediators in health institutions conflicts. (1 credit)

DD106 - International Conflict Resolution/Transformation

This subject fills the students with the knowledge and necessary skills to analyze and, if necessary, intervene in the processes of resolution and transformation of conflict and post-conflict management in the international arena. (2 credits)

DD107 - Online Dispute Resolution (ODR)

The exponential growth of the Internet and the integration into these new communication technologies of many activities, both recreational, commercial and professional, will cause -and in some countries has already happened- ODR to be a procedure by which a large number of people around the world resolve their disputes. The objective of the course is to familiarize students with this new philosophy and practice solving processes/conflict transformation online. (1 credit)

FP092- Methodology of Scientific Research

This subject presents the stages of the research process and its techniques, so that the student takes a closer look at the scientific method, and so ease their contribution within their chosen field.

(3 credits)

TFC

Broadly speaking, the process consists in the student selecting a topic of study that specially interests them, and proceeding to the creation of a monographic work. (10 credits)

2.B. MASTER IN STRATEGIC MANAGEMENT WITH A SPECIALTY IN INFORMATION TECHNOLOGY

TR026 - Business Administration and Management

This subject introduces the student to the concepts and techniques of administration and business management. It covers topics from organizational theories, until the new organizational forms in the new economy, whether for service companies, technology companies, SMES and family businesses.

(3 credits)

DD002 - Management and Cost Control

This subject is considered an introductory course for the area. Fundamental concepts of accounting are studied here, to then focus on the essential issues of management and cost controls.

The subject allows you to understand the role of information in organizations through the generation and analysis of budgets understood as the foundation of management processes and strategic planning. (2 credits)

TR047 - Financial Management

The subject highlights the most significant aspects that conceptually shape the financial direction of any company. (3 credits)

DD004 - Marketing

This subject is directed toward understanding the operation of marketing and sales in a company, introducing the concepts and techniques of marketing and business management, and to understand the meaning, nature and scope of the marketing function. (3 credits)

DD152 - Economy

It is a very necessary subject to understand the macro-economic factors that influence family enterprises and dominate aspects related to the economic theory such as consumption, inflation, demand and the GDP. (2 credits)

DD118 - Basic Statistics

This course gives the student the knowledge of basic descriptive statistics, probability and statistical inference concepts, from an eminently practical point of view. (2 credits)

DD120 - Financial Mathematics

This subject introduces the student to the phenomenon of financial assessment, especially through the assessment laws used in the practice. (1 credit)

DD124 - Management Accounting

The objective of this subject is to provide the student with a sound knowledge of the internal accounts of a company that allows them to develop its application. It will begin by defining the content of Management Accounting and its interrelationship with Financial Accounting. We will discuss the problems related to the classification, location, and the allocation of costs that allow obtaining production costs. Subsequently, using the calculated cost as a base, it will be used to guide the rational decision-making in the company to enable the efficient utilization of productive resources. (2 credits)

TR046 - Strategic Management of Human Resources

This subject is aimed at designing the conceptual and methodological framework for recognizing the systemic and strategic approach of the current Human Resources Management (HRM). (2 credits)

DD040 - Negotiation and Conflict Resolution Techniques

This subject contains information to help us understand the theoretical and practical aspects related to conflict and the most common resolution strategies: Negotiation, Mediation and Arbitration, among others. (2 credits)

DD032 - Performance Evaluation and Management by Competencies

This course explains the need to resort to specific theoretical-methodological budgets to be inserted in the skill focus of the HRM practices, to resort to the training process as the only sustainable way to maintain and revitalize these skills and their development, and use the performance appraisal process as feedback for the revitalization and development of the aforementioned labor skills. (2 credits)

TR024 - Management Techniques and Organizational Leadership

The overall objective of this subject is to know and to deepen knowledge in the styles of leadership and management, their relationship, differences, importance and theoretical approaches, as well as the competencies and skills necessary for their exercise. (2 credits)

DD090 - Business Ethics and Corporate Social Responsibilities

This subject provides the main concepts for the student to master the importance and validity of Business Ethics and Corporate Social Responsibility, recognizing them as an effective tool for

achieving competitiveness. After studying the three chapters, the student will understand the concept of ethics and social responsibility, its validity and universal character, as well as the ethical standards and their relationship with business efficiency. They will also master the relationship between business ethics, values, competitiveness, efficiency and effectiveness, and will be able to establish the ways and actions necessary for the company (and/or the company's leadership) to have an ethical and responsible behavior. (3 credits)

DD041 - Work Team Management Techniques

This subject shows the theoretical and practical elements about groups and teams, their characteristics, techniques and the tools for their effective management. (2 credits)

DD076 - Management Without Distances

The subject introduces the concepts and techniques of e-Management, explaining the meaning, nature and scope of the management and administration of projects and businesses without distance. (1 credit)

DD026 - Collaborative Work in Virtual Environments

This subject teaches the concept and the technologies associated with collaborative work from the point of view of the management of organizational teams up to the management of distance teams mediated by virtual environments. (1 credit)

DD042 - Time Management and Conducting Meetings

This subject is fundamental in order to learn how to optimize meetings in work through good preparation and the development of the same. It also provides criteria and techniques for time management within the framework of the directive function. (2 credits)

DD043 - Stress and Burnout

Teaches you how to manage situations of stress and burnout within a business organization, giving the student the necessary theoretical and practical knowledge. (2 credits)

DD044 - Public Speaking Techniques

Develops the participants' capacities to prepare and deliver professional presentations for the achievement of the desired impact in the auditorium. (1 credit)

IP082 - Quality Management: ISO 9001

After an introduction to the connotations of the term "quality", the subject is in a general way, the process of certification based on ISO 9001, since the adoption of the commitment after the introduction on the part of Management, up to being awarded the certificate. There is also a chapter devoted to quality certification in the software. (3 credits)

IP092- ISO 45001

It delves into the fundamental concepts on occupational risk prevention and the ultimate consequences of occupational accidents and diseases on people and business economics. In addition, it defines what is meant by system management and lays the basis for the implementation of a management system for the prevention of occupational hazards based on ISO 45001. (2 credits)

MA098 - Business Environmental Management. ISO 14001

Describes Environmental Management Systems (EMS) as a tool aimed at organizing and formalizing procedures for a company that takes into consideration the environmental aspects of all their activities. It also sets out, in a didactic and clear way, the steps required for implementing said environmental management instrument, aimed at environmental protection and the reduction of barriers to international trade. (3 credits)

DD012 - Operations Management and Administration

This course will deal with the activities included in the management of operations and logistics from the more strategic aspects linked to the long term decisions as the design and product definition (what do we offer?) and the design and analysis of the process (how do we get?), passing through medium and short- term tactical decisions and operational planning activities (how much, how and where do we offer it?), with the unquestionable support of the logistical tasks that make this a viable plan. In this sense, the logistics is studied as a way to provide a timely response to the requirements at the lowest possible cost. (2 credits)

DD013 - Logistics

This subject will allow you to get to know and understand the concept of logistics operations within the organization to master the management of acquisition, movement, and storage of products, and inventory control, and the information associated with all of them. (2 credits)

DD014 - Strategic Management and Planning

This course facilitates strategic thinking and provides training in the tools and mechanisms to facilitate management by accepting the contemporary management of change as something final within environments that are unstable and the variables surrounding organizations. (3 credits)

TR038 - Planning and Management of Projects

This subject is operational in nature and seeks to provide the tools to develop an operational plan from a strategic plan. (3 credits)

TI013 - Engineering, Strategy and Management of ICT Systems

This subject will include the organizational role of ICTS, from its strategic repositioning within organizational reengineering, until its strategic management as a business resource. (3 credits)

TI025 - e-Business and its Integration with Corporate Management Systems

This subject explores the concept and notion of business integration through information by reviewing the integration from the organizational and technological aspect, and the essential concepts of integration based on ICT such as ERP, SCM and CRM. (3 credits)

TI017 - Integration of Business Management Systems

This subject gives a wide and extensive view of the concept and notion of business integration through information by reviewing the integration from the organizational and technological aspect, and the essential concepts of integration based on ICT such as ERP, SCM and CRM. (5 credits)

DD162 - Marketing Strategy Development

Considered one of the major parts of this area, this course focuses on obtaining a complete vision of the various marketing aspects from the perspective of the company's strategy. The subject generates the patterns needed to know how to concentrate organizational resources for greater opportunities and achieve a sustainable competitive advantage as well. (2 credits)

TI030 - Network Security and Management

The subject prepares to use the proper tool, in every circumstance, to perform an optimum and safe management of networks. Within the correct operation, identifying the risks of information and the assurance of the system are of vital importance. (3 credits)

TI011 - Society of Change and Information.

This course will develop a vision that contextualizes the management of the cultural and technological change, providing the foundations and approaches for the transit to the Information and Knowledge Society and their organizational implications in business management. (3 credits)

DD068 - Knowledge Management and Organizational Learning

This subject presents the methodologies, tools and techniques associated with the management of knowledge and sets out in said way to achieve a sustainable strategy of organizational learning from the maturity models of knowledge management. (2 credits)

TI004/DD163 - International Commerce and Marketing

Provides a broad view of the main tools and knowledge to help face international projections along with the concepts and strategies of foreign markets, and so be able to actively participate in the business world at the international level. (4 credits)

TI014 - Trade and E-marketing

This subject shows and deepens two essential issues which are very much interlinked: electronic commerce (shown from its conceptual foundations until the technological ones) and new forms of marketing (shown from its foundations up to the change produced by the ICTs and give rise to

marketing in computing environment). The subject concludes with a methodology that proposes a marketing strategy within the space of electronic commerce. (4 credits)

TI023 - Study and Case Resolution (I, II and III)

The objective is to present a complete document that shows a total development of a case. It can be theoretical or applied, but always following the related doctrines, theories and disciplines. The case faces the student with the effective comprehension of the knowledge, and requires the student to solve a real world or simulated problem. We recommend that it is started at the end of the last subject, because at this time the student will have the necessary resources to develop it quickly and methodically. (10 credits)

TI015 - Electronic and Legislation Security

This subject shows the complexity of the nature of the risks incurred to the general and comprehensive utilization of information technology, both from a technological perspective and the possible legal liability arising from the illegal or abusive use of them. (4 credits)

TI016 - Business Intelligence

This subject allows knowing the field of Business Intelligence in their technical and business aspects and then finish with a review of the impact on the management of information and documentary content. (4 credits)

TI018 - Innovation, Culture and Work Management in the Communication Society

This subject reviews the changes that society has undergone in some cultural aspects especially in relation to work. (2 credits)

TI043 - Management and Administration of IT Projects

This subject presents the best management practices for e-business technology projects from a paradigm that combines the business acumen with technological vision, and based on one side, the PMBOK as a source of good management practices and, on the other hand, software engineering, as a source of best practices related to ICT projects. (4 credits)

TI034 - Languages and Programming Paradigms

This subject shows an overview of programming languages, as well as the particular philosophy of building these tools that enable the world to move by means of computers. In this exhibition space of languages and programming paradigms, the programming models that define languages and paradigms gain strength. Also, the subject can deepen the theoretical issues of functional programming, with the use of Scheme, a programming language that can be used for the implementation of several programming models which allows the conceptualization of this programming paradigm. (2 credits)

TI035 - Architectures, Networks and Distributive Systems

This subject reviews the basic concepts of computer networks and distributed systems in a descriptive manner, based on the architecture of the current Internet and its relationship to high performance distributed system architecture, and introduces the important issues related to the availability, security, reliability and integrity of information within and between networks. (3 credits)

TI036 - Web Technology and Engineering

The subject reviews all the concepts, features, and components related to the Web, both from the point of view of Web technologies and from the Web Engineering that seeks to produce reliable systems and applications, ubiquitous and high quality techniques. (3 credits)

TI037 - Integral Design and Analysis of Systems and Requirements

The subject presents a comprehensive view of the study of organizational systems from all dimensions of analysis and design: first from the systems to the requirements and, on the other hand, from the organizational perspective to the level of detail of the data. (3 credits)

TI038 - Data Model and Database Design

The subject introduces the concepts and database modeling mechanism. It also affects the relational model as a modeling tool based on the ERD (Entity Relationship Diagram) model and the use of types and subtypes as basic units of information. Storing information with data normalization is optimized to avoid redundancy. (3 credits)

TI040 - Management of Databases and Information Resources

The subject takes an overview of the concepts and solutions that an Administrator of Information Technology must know for proper information management in their organization as part of a software engineering project. (3 credits)

TI041 - Business Software Process

The subject introduces the concept and notion of software processes understood as an organizational tool and a sign of organizational maturity of IT units in order to interpret the process as a software enterprise business unit. The software process is presented linked to the traditional paradigms of software widely used in the planning of software projects and also presents concepts associated with software projects. Finally, the software process is related to the structure of a project office as an instance of organizational knowledge in management activities associated with software in an organization; concepts and essential characteristics of a software process. (3 credits)

FP092- Methodology of Scientific Research

This subject presents the stages of the research process and its techniques, so that the student takes a closer look at the scientific method, and so ease their contribution within their chosen field. (3 credits)

TFC

Broadly speaking, the process consists in the student selecting a topic of study that specially interests them, and proceeding to the creation of a monographic work. (10 credits)

2.C. MASTER IN STRATEGIC MANAGEMENT WITH A SPECIALTY IN TELECOMMUNICATIONS

TR026 - Business Administration and Management

This subject introduces the student to the concepts and techniques of administration and business management. It covers topics from organizational theories, until the new organizational forms in the new economy, whether for service companies, technology companies, SMES and family businesses. (3 credits)

DD002 - Management and Cost Control

This subject is considered an introductory course for the area. Fundamental concepts of accounting are studied here, to then focus on the essential issues of management and cost controls.

The subject allows you to understand the role of information in organizations through the generation and analysis of budgets understood as the foundation of management processes and strategic planning. (2 credits)

TR047 - Financial Management

The subject highlights the most significant aspects that conceptually shape the financial direction of any company. (3 credits)

DD004 - Marketing

This subject is directed toward understanding the operation of marketing and sales in a company, introducing the concepts and techniques of marketing and business management, and to understand the meaning, nature and scope of the marketing function. (3 credits)

DD152 - Economy

It is a very necessary subject to understand the macro-economic factors that influence family enterprises and dominate aspects related to the economic theory such as consumption, inflation, demand and the GDP. (2 credits)

DD118 - Basic Statistics

This course gives the student the knowledge of basic descriptive statistics, probability and statistical inference concepts, from an eminently practical point of view. (2 credits)

DD120 - Financial Mathematics

This subject introduces the student to the phenomenon of financial assessment, especially through the assessment laws used in the practice. (1 credit)

DD124 - Management Accounting

The objective of this subject is to provide the student with a sound knowledge of the internal accounts of a company that allows them to develop its application. It will begin by defining the content of Management Accounting and its interrelationship with Financial Accounting. We will discuss the problems related to the classification, location, and the allocation of costs that allow obtaining production costs. Subsequently, using the calculated cost as a base, it will be used to guide the rational decision-making in the company to enable the efficient utilization of productive resources. (2 credits)

TR046 - Strategic Management of Human Resources

This subject is aimed at designing the conceptual and methodological framework for recognizing the systemic and strategic approach of the current Human Resources Management (HRM). (2 credits)

DD040 - Negotiation and Conflict Resolution Techniques

This subject contains information to help us understand the theoretical and practical aspects related to conflict and the most common resolution strategies: Negotiation, Mediation and Arbitration, among others. (2 credits)

DD032 - Performance Evaluation and Management by Competencies

This course explains the need to resort to specific theoretical-methodological budgets to be inserted in the skill focus of the HRM practices, to resort to the training process as the only sustainable way to maintain and revitalize these skills and their development, and use the performance appraisal process as feedback for the revitalization and development of the aforementioned labor skills. (2 credits)

TR024 - Management Techniques and Organizational Leadership

The overall objective of this subject is to know and to deepen knowledge in the styles of leadership and management, their relationship, differences, importance and theoretical approaches, as well as the competencies and skills necessary for their exercise. (2 credits)

DD090 - Business Ethics and Corporate Social Responsibilities

This subject provides the main concepts for the student to master the importance and validity of Business Ethics and Corporate Social Responsibility, recognizing them as an effective tool for achieving competitiveness. After studying the three chapters, the student will understand the concept of ethics and social responsibility, its validity and universal character, as well as the ethical standards and their relationship with business efficiency. They will also master the relationship between business ethics, values, competitiveness, efficiency and effectiveness, and will be able to establish

the ways and actions necessary for the company (and/or the company's leadership) to have an ethical and responsible behavior. (3 credits)

DD041 - Work Team Management Techniques

This subject shows the theoretical and practical elements about groups and teams, their characteristics, techniques and the tools for their effective management. (2 credits)

DD076 - Management Without Distances

The subject introduces the concepts and techniques of e-Management, explaining the meaning, nature and scope of the management and administration of projects and businesses without distance. (1 credit)

DD026 - Collaborative Work in Virtual Environments

This subject teaches the concept and the technologies associated with collaborative work from the point of view of the management of organizational teams up to the management of distance teams mediated by virtual environments. (1 credit)

DD042 - Time Management and Conducting Meetings

This subject is fundamental in order to learn how to optimize meetings in work through good preparation and the development of the same. It also provides criteria and techniques for time management within the framework of the directive function. (2 credits)

DD043 - Stress and Burnout

Teaches you how to manage situations of stress and burnout within a business organization, giving the student the necessary theoretical and practical knowledge. (2 credits)

DD044 - Public Speaking Techniques

Develops the participants' capacities to prepare and deliver professional presentations for the achievement of the desired impact in the auditorium. (1 credit)

IP082 - Quality Management: ISO 9001

After an introduction to the connotations of the term "quality", the subject is in a general way, the process of certification based on ISO 9001, since the adoption of the commitment after the introduction on the part of Management, up to being awarded the certificate. There is also a chapter devoted to quality certification in the software. (3 credits)

IP092- ISO 45001

It delves into the fundamental concepts on occupational risk prevention and the ultimate consequences of occupational accidents and diseases on people and business economics. In addition, it defines what is meant by system management and lays the basis for the implementation of a management system for the prevention of occupational hazards based on ISO 45001. (2 credits)

MA098 - Business Environmental Management. ISO 14001

Describes Environmental Management Systems (EMS) as a tool aimed at organizing and formalizing procedures for a company that takes into consideration the environmental aspects of all their activities. It also sets out, in a didactic and clear way, the steps required for implementing said environmental management instrument, aimed at environmental protection and the reduction of barriers to international trade. (3 credits)

DD012 - Operations Management and Administration

This course will deal with the activities included in the management of operations and logistics from the more strategic aspects linked to the long term decisions as the design and product definition (what do we offer?) and the design and analysis of the process (how do we get?), passing through medium and short- term tactical decisions and operational planning activities (how much, how and where do we offer it?), with the unquestionable support of the logistical tasks that make this a viable plan. In this sense, the logistics is studied as a way to provide a timely response to the requirements at the lowest possible cost. (2 credits)

DD013 - Logistics

This subject will allow you to get to know and understand the concept of logistics operations within the organization to master the management of acquisition, movement, and storage of products, and inventory control, and the information associated with all of them. (2 credits)

DD014 - Strategic Management and Planning

This course facilitates strategic thinking and provides training in the tools and mechanisms to facilitate management by accepting the contemporary management of change as something final within environments that are unstable and the variables surrounding organizations. (3 credits)

TR038 - Planning and Management of Projects

This subject is operational in nature and seeks to provide the tools to develop an operational plan from a strategic plan. (3 credits)

TI013 - Engineering, Strategy and Management of ICT Systems

This subject will include the organizational role of ICTS, from its strategic repositioning within organizational reengineering, until its strategic management as a business resource. (3 credits)

TI025 - e-Business and its Integration with Corporate Management Systems

This subject explores the concept and notion of business integration through information by reviewing the integration from the organizational and technological aspect, and the essential concepts of integration based on ICT such as ERP, SCM and CRM. (3 credits)

TI017 - Integration of Business Management Systems

This subject gives a wide and extensive view of the concept and notion of business integration through information by reviewing the integration from the organizational and technological aspect, and the essential concepts of integration based on ICT such as ERP, SCM and CRM. (5 credits)

DD162 - Marketing Strategy Development

Considered one of the major parts of this area, this course focuses on obtaining a complete vision of the various marketing aspects from the perspective of the company's strategy. The subject generates the patterns needed to know how to concentrate organizational resources for greater opportunities and achieve a sustainable competitive advantage as well. (2 credits)

TI030 - Network Security and Management

The subject prepares to use the proper tool, in every circumstance, to perform an optimum and safe management of networks. Within the correct operation, identifying the risks of information and the assurance of the system are of vital importance. (3 credits)

TI011 - Society of Change and Information.

This course will develop a vision that contextualizes the management of the cultural and technological change, providing the foundations and approaches for the transit to the Information and Knowledge Society and their organizational implications in business management. (3 credits)

DD068 - Knowledge Management and Organizational Learning

This subject presents the methodologies, tools and techniques associated with the management of knowledge and sets out in said way to achieve a sustainable strategy of organizational learning from the maturity models of knowledge management. (2 credits)

TI004/DD163 - International Commerce and Marketing

Provides a broad view of the main tools and knowledge to help face international projections along with the concepts and strategies of foreign markets, and so be able to actively participate in the business world at the international level. (4 credits)

TI014 - Trade and E-marketing

This subject shows and deepens two essential issues which are very much interlinked: electronic commerce (shown from its conceptual foundations until the technological ones) and new forms of marketing (shown from its foundations up to the change produced by the ICTs and give rise to marketing in computing environment). The subject concludes with a methodology that proposes a marketing strategy within the space of electronic commerce. (4 credits)

TI026 - Telecommunications Marketing

The course prepares the student for a critical view of the evolution undergone by the telecommunications market and the changes in which we are immersed. Current strategic decisions will mark the evolution of the sector in the medium to long term with a profound imprint. (3 credits)

TI027 - Technical-Business Structure of Telecommunications

The course prepares the student to know the agents that make up the value chain of telecommunication and their interrelationships. It also shows different business models to maximize profits in their respective market segments. (3 credits)

TI028 - Telecommunications Networks

The course trains students to understand the various current and future technological possibilities in areas related to infrastructure for the transmission of information through telecommunication networks. (3 credits)

TI029 - Telecommunications Services

The course prepares students to acquire the basic concepts of telecommunications services, focusing its analysis on the possibilities of business development. (2 credits)

TI031 - Telecommunications Marketing Regulations

The course trains students to understand the importance of regulation in telecommunications as one of the basic determinant pillars of progression of the Information Society. (2 credits)

TI016 - Business Intelligence

This subject enables understanding the field of Business Intelligence in their technical and business aspects and then finish with a review of the impact on the management of information and documentary content. (4 credits)

TI020 - e-Business Project Management

This subject presents the best management practices for e-business technology projects from a paradigm that combines the business acumen with technological vision, and based on one side, the PMBOK as a source of good management practices and, on the other hand, software engineering, as a source of best practices related to ICT projects. (4 credits)

FP092- Methodology of Scientific Research

This subject presents the stages of the research process and its techniques, so that the student takes a closer look at the scientific method, and so ease their contribution within their chosen field. (3 credits)

TFC

Broadly speaking, the process consists in the student selecting a topic of study that specially interests them, and proceeding to the creation of a monographic work. (10 credits)

3. DEPARTMENT OF PROJECTS

3.A. DOCTORATE IN PROJECTS WITH A SPECIALTY IN RESEARCH

DD070 - Introduction to Project Management

The subject covers, among other things, the following topics: general concepts of project management and the types of projects, the phases of a project and the project life cycle. It does so from a pragmatic and professional point of view that enables developing and consolidating the research competences in this context.

TR038 - Planning and Programming of Projects

This subject delves into the concepts and development of the project plan and control of its possible changes; defining, administrating and planning the project scope, and choosing and applying the appropriate techniques for producing an action plan, since it is impossible to think about project management without it being planned. In this way, the student performs research tasks of various project planning techniques.

DD073 - Project Control

This subject addresses project control from a general perspective with topics such as knowing the fundamentals of project control and its tools and methodologies, to the particular, such as the control of technical and human resources to ensure compliance in time, quality and costs; through research and the analysis of several current tools.

D0005 - Methodology of Scientific Research I. Foundations

Research is essential for doctoral students since it is essential that they acquire the basic training necessary to be able to write their doctoral thesis and do so with the highest possible quality. This subject presents the student with the basic concepts and foundations of research.

D00014 - Methodology of Scientific Research II. Paradigms and Methods

This subject presents the stages of the research process and its techniques, by which the student will take a closer look at the scientific method, and so facilitate their contribution within their chosen field.

D00011 - Research Seminar (Doctoral File)

This subject enables students to actively participate in a doctoral research seminar during which they will analyze and show the initial structure of the research work that they wish to develop. In order to do

so, they will have to start consulting and reviewing specialized sources. The student will develop a research protocol (doctoral file), in which they will have to define a tentative topic.

DD026 - Collaborative Work in Virtual Environments

The subject introduces the student to the "world" of technologies related to the collaborative work whose aim is to achieve the goals of the same group, ranging from the management of organizational teams, up to the management of distant teams mediated by virtual working environments. This enables the student to carry out research tasks related to the application of these collaborative work tools when formulating projects.

DD235 - Introduction to the Project Design: from the Conflict to the Technical Problem

This subject introduces the student to the concepts of a "Project" within a theoretical framework and in a general way, such as: project phases, project systems, collaborative work, and knowledge management for the project's success, as well as their designs. This achieved by focusing on research, investigating the elements that define the project's goal and scope, in order to establish a knowledge base that leads to the development of the remaining subjects, which are part of an established project design methodology.

DD236 - Systems Design - Project Solutions

Provides the concepts related to identifying the project scenario, researching the factors that predetermine its solutions, establishing the technical problem, formulating the objectives, the criteria used for evaluating the project's success, as well as the identification and analysis of all the persons and things involved in solving the problem.

DD237 - Desired Service and Conditions for Provision

This subject develops, investigates and determines the conditions of supply and regularization between the customer needs and what science and engineering would provide as a solution, considering this solution as the project itself, requiring that we define the "desired" service to be obtained as a result. The student will also develop effective consulting works.

DD238 - System Solution: Functional Analysis in the Project

During the development of the present subject, the student will seek to determine the technical functions and services to meet the project that is being designed by means of the service tree as a "conceptual tool", the proposed project system, value analysis and quality in the design phase. This enables the student to develop their analytical and research skills within specific environments and contexts.

D0012 - Cross-Training Workshop I

The purpose of this activity is to reflect, revise and apply the knowledge obtained from the subjects up to now: From the Conflict to the Technical Problem; System solutions; Desired Service and the Conditions of Provision and THE System Solutions that will provide the service. This will be carried out in a group and within a collaborative environment.

DD239 - Roles of People in the Project

This subject lets the student understand, identify and classify the role of people in their activities and their employment for a project solution and their relationship with other people and machines, for which it establishes a classification of users, security measures, etc. through meticulous research and analysis using defined tools.

DD240 - Project Security and Reliability

This subject covers topics related to understanding aspects of the safety and feasibility of a project solution contemplating its states of life, its life-cycle, at the system level and its components, including people, machines and their relationships.

DD241 - Environmental Viability of the Project

By studying the project's sustainability, eco-design, environmental impact and life cycle analysis, which are the topics this subject delves into, the student will understand the field of a project solution in its states of life, its life-cycle, and at the system level and its components. This is achieved with research on the surrounding environment and by taking legal and regulatory aspects into consideration.

D0013 - Cross-Training Workshop II

The purpose of this activity is to reflect, revise and apply the knowledge obtained from the subjects up to now: Roles of People in the Project, Project Security and Reliability and Environmental Viability of the Project This will be carried out in a group and within a collaborative environment.

DD242 - Project Proposal: Specifications

This subject enables the student to detail, specify and explain the operation and constitution of the potential solution provided by a project. This is to say, it is the systematic and analytical integration of the previous subjects within a technical project and the result of research and analysis activities.

DD243 - Project Draft Preparation

This subject, by means of such topics as tools for specification, documentation, and the development of the project proposal, will help the student to understand the importance of management as an ulterior step in design and be able to create a proposal for a viable and sustainable management.

D0006 - Research Work I

An important activity in the student's education within the doctoral program is to carry out a research work, which represents the application of the theoretical concepts learned with that of their own vision, and a research methodology applied within a defined line of work.

Once the student has completed and passed the general and core subjects in accordance with the evaluation system, they will carry out a research project supervised by the Thesis Director. This work will be carried out according to a determined line of research and subsequent and/or related to Research Work I, according to the chosen line of research.

D0007 - Research Work II

Once the student has completed and passed the general and core subjects in accordance with the evaluation system, they will carry out a research project supervised by the Thesis Director. This work will be carried out according to a determined line of research and subsequent and/or related to Research Work I, according to the chosen line of research.

D000248 - Doctoral Thesis Proposal

Taking into account the results from Research Work I and II, the doctoral student will prepare the proposal for their doctoral thesis. The doctoral student will request the defense of their doctoral thesis before a board authorized by the Doctoral Commission. This defense is a requirement for remaining in the doctorate program. Once this presentation has been passed, and if an approval has been obtained, the candidate will be considered a Doctoral Candidate.

D0009 - Doctoral Thesis Development

A doctoral thesis is an original research work written on a specific topic, and in this case, on a defined line of research supervised by the Thesis Director assigned by the Doctorates Director. The work must be individual and, above all, original, focusing on a topic of scientific research in the area of Administration and deriving from a line of research in accordance with social, economic and technological development.

The importance of this work lies in the fact that, once the doctoral thesis project is approved, the doctoral candidate delves into and consolidates the hypotheses raised in the research, obtaining real results in a systemic way (with exhaustive documentation, data compilation and filing, an experimental part and data analysis and conclusions to finally continue with the writing), which in itself is a contribution to the state of the art and knowledge of the area.

D0010 - Doctoral Thesis Dissertation

The scientific dissertation is a written work aimed at a presentation on reasoning, in this case, of the results obtained and systematized from the previously carried out doctoral research work, which will subsequently be presented orally. This will be carried out through a doctoral degree exam that will be supported according to the mechanics described for the Doctoral Thesis Project. The doctoral student will request the defense of their doctoral thesis before a board authorized by the Doctoral Commission.

Once the student has passed this exam, they will complete the credits established in the program and be awarded the degree of *Doctor in Projects with a Specialty in Research*.

The dissertation of the Doctoral Thesis is part of the program's educational activities, since it evaluates the results obtained in the research within quantitative and qualitative aspects from a defined hypotheses; the methodological criteria used to carry it out, its applicability, as well as the synthesis, writing and communication skills by the doctoral candidate. This last part is essential for the doctoral candidate's formation in their specialty in Research.

3.B. MASTER IN PROJECT DESIGN, ADMINISTRATION AND MANAGEMENT

DD050 - Introduction to Projects

This subject introduces the student, within a theoretical framework and in a general way, to the concepts of a "Project", such as: project phases, project systems, collaborative work, and knowledge management for the project's success, as well as their designs. This is to establish a knowledge base conducive to the undertaking the the subjects that follow. (1 credit)

DD051 - Project System Design

Provides concepts related to the identification of the project scenario, the factors that condition its solutions, establishing the technical problem, the formulation of the objectives, the criteria used for evaluating the success of the project, as well as the identification and analysis of all the persons and things involved in the resolution of the problem, understood as a fundamental part in the trilogy of man - artificial system - environment. (2 credits)

DD052 - Analysis of Provision of Services

This subject develops, investigates and determines the conditions of supply and regularization between the customer needs and what science and engineering would provide as a solution, considering this solution as the project itself, requiring that we define the "desired" service to be obtained as a result. (2 credits)

DD053 - Functional Analysis of the Project

During the development of the present subject we seek to determine the technical functions and services to meet the project we are designing, by means of the service tree as a "conceptual tool", the proposed project system, the value analysis and quality in the design phase. (2 credits)

DD054 - Project Ergonomics

This subject deals with understanding the role of the people in their activities and its uses in the solution of a project and its relationship with other people and machines, for which it establishes a classification of users, security measures, etc. (2 credits)

DD055 - Project Security and Reliability

This subject covers topics related to understanding aspects of the safety and feasibility of a project solution contemplating its states of life, its life-cycle, at the system level and its components, including people, machines and their relationships. (2 credits)

DD056 - Environment in a Project

By studying the project's sustainability, eco-design, environmental impact and life cycle analysis, which are the topics to delve into this subject, we understand the environment of a project solution in their states of life, its life-cycle, and at the system level and its components. (2 credits)

DD057 - Project Specifications

This subject will allow us to learn in detail, specify and explain the operation, detail and constitution of the potential solution provided by a project. (2 credits)

DD058 - Project Draft Preparation

This subject, by means of such topics as tools for specification, documentation, and the development of the project proposal, will help us to understand the importance of management as an ulterior step in design and be able to generate a proposal for a viable and sustainable management. (3 credits)

DD070 - Introduction to Project Management

Management/project management is the administration of all the necessary resources for the development of the same, as this course introduces us into the topic in a general way and covers, among other things, the following topics: general concepts of project management and types of projects, phases of a project and project life cycle. (1 credit)

TR038 - Planning and Management of Projects

The planning and management of projects are closely linked, since it is impossible to think of management without planning it. For this it is necessary to bear in mind some concepts: developing the project plan and the control of its possible changes, definition, administration and planning of the project scope, and choose and apply the appropriate techniques to produce a plan of action. (3 credits)

DD072 - Computing Tools for Project Management

This subject introduces us to the main computer tools to support the management of a project, and also teach us to know its advantages. Every project needs to be managed, and to complement this, it is also necessary to have the knowledge and handling of computer tools in accordance with the typology of each project. (2 credits)

DD073 - Project Monitoring and Control

Surely the job of monitoring and control should be one that requires a greater commitment, and this is why the subject is presented with general topics like: learning the fundamentals of project control and their tools and methodologies, all the way to the particular, like carrying out the control of human and technical resources to ensure compliance with time, quality and cost. (2 credits)

DD074 - Project Evaluation

The evaluation of projects keeps us focused on the task of understanding and structuring financial engineering by means of numerous technical-economical tools, so as to learn to see projects not only by means of detailed drawings, or flowcharts, but also by spreadsheets of financial economic development. (2 credits)

DD075 - Trust Management: Risk and Quality.

Trust management focuses mainly on evaluating and learning the fundamentals of quality in projects, and their tools and methodologies, learning how to plan, guarantee and control quality, and risk. (2 credits)

TR046 - Strategic Management of Human Resources

This subject gives us a complete vision of the role of the Human Resource's director in the twenty-first century, reviewing the areas of activity in management, and its integration into the business strategy. (2 credits)

IP092 - ISO 45001

The foundations are laid for implementing a health and safety management system in the company based on the ISO 45001 standard. (2 credits)

DD077 - Project Communication

The issue involved in this subject deals with the "inward" and "outwards" communication of a project, toward the three levels of users, from the basic circuits of communication up to the more complex structures of strategic communication, where the image of the same compromises with the social ideal. (1 credit)

DD026 - Collaborative Work in Virtual Environments

This subject introduces the student to the "world" of technologies related to the collaborative work whose aim is to achieve the goals of the same group, ranging from the management of organizational teams, up to the management of distant teams mediated by virtual working environments. (1 credit)

DD076 - Management Without Distances

This subject helps us to understand the complex process, the tools, the possible methodologies and typologies of a project's off-shore management. Project management carried out at a distance. In order to understand this topic in depth we need to talk about concepts such as: cooperative and collaborative construction of knowledge and cooperative models of participation, supported by information technologies. (1 credit)

DD044 - Public Speaking Techniques

This subject has an increasing role in project management since it trains managers with the skills for promoting projects and their products, so as to obtain investors or at least interest within the market. It covers knowledge on communication strategies, and knowing how best to define the characteristic elements of the project that will shape its image. (1 credit)

TR026 - Business Administration and Management

This subject introduces the student to the concepts and techniques of administration and business management. It covers topics from organizational theories, until the new organizational forms in the

new economy, whether for service companies, technology companies, SMES and family businesses. (3 credits)

DD014 - Strategic Management and Planning

This subject establishes the tools needed for the strategic management and mastery of the strategic planning process as the first basic steps for the project director, moving through such necessary topics like the mission, vision and values, chain value, SWOT analysis, selecting the strategies and the Balance Scorecard. (3 credits)

DD040 - Negotiation and Conflict Resolution Techniques

This subject has everything we require and even more for the professional life we form with theoretical and practical knowledge, to conflict solutions, solution strategies, and basic skills for its solution. (2 credits)

DD041 - Work Team Management Techniques

This subject presents different management and direction techniques for teamwork where the main thing is the human resource with which we count upon and that we must "take care of". That is why we must additionally know about management tools to ensure the management of these resources in an efficient manner. (2 credits)

DD068 - Knowledge Management and Organizational Learning

During the course of this subject we will identify and analyze each one of the types of knowledge for enterprises in the area of management, diagnostics, distribution and availability of information as key factors for success. Knowledge management is an "activity" that must be present in all professional activity and even more so if you are in a position of leadership. (2 credits)

TI025 - e-Business and its Integration with Corporate Management Systems

This subject gives a wide and extensive view of the concept and notion of business integration through information by reviewing the integration from the organizational and technological aspect, and the essential concepts of integration based on ICT such as ERP, SCM and CRM. (3 credits)

PC012 - International Collaboration System

This subject is an exegesis on the subjects that concern society as a global community as affected by such phenomenons as migration, terrorism, business without borders, the global economy, international sports, etc. It provides a cooperative vision within the complex scene of international relationships. International processes and structures are presented as well as the effects of cooperative agents within the capabilities of contemporary states in a theoretical context. (1 credit)

PC013 - Logical Framework

This subject studies the Logical Framework at the theoretical and application levels. Each step and tool that includes it is studied, while cases in which it is used at both the international cooperation level as at the projects level that are not of international cooperation, are also reviewed. (2 credits)

DD090 - Corporate Social Responsibilities and Ethics

Concepts are provided that allow the mastery about the importance and validity of Business Ethics and Corporate Social Responsibility, and recognize it as an effective tool for achieving competitiveness and development and for the social and economic progress of individuals, nations, societies and communities. (3 credits)

PC002 - Collaboration and Development Theory

Examines the historical evolution, motivations and rationale for the development of international cooperation, as well as its instruments and purposes. The subject studies the role of international cooperation in the decentralization and the prevailing conception of cooperation for development. The machinery for official aid is also studied (donor countries, World Bank, etc.). We review the effect of the governance versus the goals of development. Explore private financing. The impact of globalization on cooperation is studied. Explore the origins and theory of development, at the theoretical and historical level. It contrasts human development versus economic development (HDI, HPI, IDG, IPG, IAT, etc.). It studies international relations and its relationship to the development of cooperation. An interpretative framework for international assistance in historical terms is also studied (Pearson and Peterson Reports, etc.). And it studies the geopolitical rupture and epistemological paradigm of development. (3 credits)

TR047 - Financial Management

The subject highlights the most relevant aspects that constitute the financial management for any company, contributing examples that are easy to study and understand, as well as practice exercises. (3 credits)

DD102 - Resolution/Transformation of Conflict in the Community

Brings mediators closer to a specific training regarding the different themes present in conflicts which arise in urban neighborhood - community relations, be they public or private. The subject presents the perspective and the particular focus of the Community Mediation from an interdisciplinary approach, oriented to the new sociocultural conditions marked by differences and inequality. At the same time, it analyzes the profile of the mediator suitable to these scenarios, meaning one who is involved in the challenge of forming a pluralistic society-city, equitable and inclusive. (2 credits)

FP092- Methodology of Scientific Research

This subject presents the stages of the research process and its techniques, so that the student takes a closer look at the scientific method, and so ease their contribution within their chosen field. (3 credits)

FMP/Practicum

Although the Practicum and the Final Draft are collected separately in the program, both are two different phases of the same process that culminates in the presentation of a single work. Broadly speaking, the process consists in the student selecting a topic of study that specially interests them, and proceeding to the creation of a monographic work. The Practicum part would correspond to the phase of the study, analysis, or design field. (10 credits)

3.C. MASTER IN PROJECT DESIGN, ADMINISTRATION AND MANAGEMENT WITH A SPECIALTY IN ARCHITECTURE AND URBAN PLANNING

DD050 - Introduction to Projects

This subject introduces the student, within a theoretical framework and in a general way, to the concepts of a "Project", such as: project phases, project systems, collaborative work, and knowledge management for the project's success, as well as their designs. This is to establish a knowledge base conducive to the undertaking the the subjects that follow. (1 credit)

DD051 - Project System Design

Provides concepts related to the identification of the project scenario, the factors that condition its solutions, establishing the technical problem, the formulation of the objectives, the criteria used for evaluating the success of the project, as well as the identification and analysis of all the persons and things involved in the resolution of the problem, understood as a fundamental part in the trilogy of man - artificial system - environment. (2 credits)

DD052 - Analysis of Provision of Services

This subject develops, investigates and determines the conditions of supply and regularization between the customer needs and what science and engineering would provide as a solution, considering this solution as the project itself, requiring that we define the "desired" service to be obtained as a result. (2 credits)

DD053 - Functional Analysis of the Project

During the development of the present subject we seek to determine the technical functions and services to meet the project we are designing, by means of the service tree as a "conceptual tool", the proposed project system, the value analysis and quality in the design phase. (2 credits)

DD054 - Project Ergonomics

This subject deals with understanding the role of the people in their activities and its uses in the solution of a project and its relationship with other people and machines, for which it establishes a classification of users, security measures, etc. (2 credits)

DD055 - Project Security and Reliability

This subject covers topics related to understanding aspects of the safety and feasibility of a project solution contemplating its states of life, its life-cycle, at the system level and its components, including people, machines and their relationships. (2 credits)

DD056 - Environment in a Project

By studying the project's sustainability, eco-design, environmental impact and life cycle analysis, which are the topics to delve into this subject, we understand the environment of a project solution in their states of life, its life-cycle, and at the system level and its components. (2 credits)

DD057 - Project Specifications

This subject will allow us to learn in detail, specify and explain the operation, detail and constitution of the potential solution provided by a project. (2 credits)

DD058 - Project Draft Preparation

This subject, by means of such topics as tools for specification, documentation, and the development of the project proposal, will help us to understand the importance of management as an ulterior step in design and be able to generate a proposal for a viable and sustainable management. (3 credits)

DD070 - Introduction to Project Management

Management/project management is the administration of all the necessary resources for the development of the same, as this course introduces us into the topic in a general way and covers, among other things, the following topics: general concepts of project management and types of projects, phases of a project and project life cycle. (1 credit)

TR038 - Planning and Management of Projects

The planning and management of projects are closely linked, since it is impossible to think of management without planning it. For this it is necessary to bear in mind some concepts: developing the project plan and the control of its possible changes, definition, administration and planning of the project scope, and choose and apply the appropriate techniques to produce a plan of action. (3 credits)

AU001 - Architecture and Urbanism Interrelations

This subject deals with analyzing the different approaches that arise from the scales of analysis and disciplinary intervention of architecture, urban design and urban planning, analyzing the specific characteristics of each one of them, their differences, their commonalities and complementarities, oriented toward the need for their integration to the professional action in the urban space, contributing to a better quality of life for the population. (2 credits)

DD073 - Project Monitoring and Control

Surely the job of monitoring and control should be one that requires a greater commitment, and this is why the subject is presented with general topics like: learning the fundamentals of project control and their tools and methodologies, all the way to the particular, like carrying out the control of human and technical resources to ensure compliance with time, quality and cost. (2 credits)

AU002 -The Environment in Urban Planning - Architectural Projects

Based on the definition of a series of environmental concepts and basic socio-economics that are involved in the concept of sustainable development, the subject delves into the background and the problems caused by the environmental impacts of human activities, from a global scale to the urban and architectural intervention, providing a series of principles that guide said action. (2 credits)

DD075 - Trust Management: Risk and Quality.

Trust management focuses mainly on evaluating and learning the fundamentals of quality in projects, and their tools and methodologies, learning how to plan, guarantee and control quality, and risk. (2 credits)

AU003 - Technology Impact in Urban Architectural Projects

Studying the relationship between new technologies, city, and architectural design, is an urgent issue for professionals and researchers involved in the planning and management of urban - architectural projects.

The subject will analyze how technological innovations have a transformative effect, both in socio-economic relations as in the urban form, and how they are manifested in the cities and in the way in which architects, town planners and managers develop their planning and architectural projects.

It focuses on the search for social responses to the changes that new technologies bring in the ways of living in cities, and to include them as design elements. (2 credits)

AU004 - Contextual Components of the Project: Economic, Social, Institutional and Cultural

The subject will address the various kinds of contextual changes: economic, social, institutional, cultural, etc., that affect the design and development of an urban-architectural project.

We analyze the relationship between society, the State and productive points, the relations of the local market in the global market and the role of some key players in society, so that from their knowledge, we can work the conditional factors and their relationships within the design and development of a project in order to characterize them in different ways.

Each of the analyzed fields will allow the student to generate different lines of work in a project and provide an integrated focus of the problem being addressed. (2 credits)

AU005 - City Marketing

This subject aims to provide tools for which the student can identify distinctive elements or a representation of a city or the marketing tools of cities; relating the latter concept as a set of activities and a range of products and/or services of the city designed to meet the needs of different audiences (internal and external audiences), creating and fostering their demand.

This will be analyzed for instruments of communication, advertising and promotion, as well as the decision-making process of the different social actors (social, economic and political); and, on the other hand, the knowledge of the characteristics of the urban model that the citizens themselves want. (2 credits)

AU006 - Architectural-Urban Project Theory

The subject introduces the concept of "project" in the performance of architecture, urban design and urban planning, associating it and distinguishing it from the processes of research and design.

Inclusion of the social, environmental, economic and political dimensions of the project in the urban-architectural. Introduction to the formulation, management and direction of urban-architectural projects. General concepts on Systems and General Systems Theory, with the aim of providing a tool to analyze the problems, conflicts and urban-architectural projects with a systemic vision aimed at understanding the diversity and complexity of the present city. (1 credit)

DD076 - Management Without Distances

This subject helps us to understand the complex process, the tools, the possible methodologies and typologies of a project's off-shore management. Project management carried out at a distance. In order to understand this topic in depth we need to talk about concepts such as: cooperative and collaborative construction of knowledge and cooperative models of participation, supported by information technologies. (1 credit)

DD044 - Public Speaking Techniques

This subject has an increasing role in project management since it trains managers with the skills for promoting projects and their products, so as to obtain investors or at least interest within the market. It covers knowledge on communication strategies, and knowing how best to define the characteristic elements of the project that will shape its image. (1 credit)

TR026 - Business Administration and Management

This subject introduces the student to the concepts and techniques of administration and business management. It covers topics from organizational theories, until the new organizational forms in the new economy, whether for service companies, technology companies, SMES and family businesses. (3 credits)

DD014 - Strategic Management and Planning

This subject establishes the tools needed for the strategic management and mastery of the strategic planning process as the first basic steps for the project director, moving through such necessary topics like the mission, vision and values, chain value, SWOT analysis, selecting the strategies and the Balance Scorecard. (3 credits)

AU007 - Preservation of the Architectural Urban Heritage

This subject aims to highlight the objects produced by a community that are in an urban property of heritage value. When we talk about property we are referring to the tangible heritage including public spaces (with varying degrees of human intervention) that meet environmental functions and recreation.

The identification of the city's cultural system and the location of the architectural elements with historical dimension will be performed, while studying the interplay of cultural property in the different scales in which they are displayed and the processes and agents that affect them in each one.

It is intended for the student to acquire the ability to integrate the technical, cultural and/or socio-economic problems in the practice of cultural property conservation. (2 credits)

DD041 - Work Team Management Techniques

This subject presents different management and direction techniques for teamwork where the main thing is the human resource with which we count upon and that we must "take care of". That is why we must additionally know about management tools to ensure the management of these resources in an efficient manner. (2 credits)

DD068 - Knowledge Management and Organizational Learning

During the course of this subject we will identify and analyze each one of the types of knowledge for enterprises in the area of management, diagnostics, distribution and availability of information as key factors for success. Knowledge management is an "activity" that must be present in all professional activity and even more so if you are in a position of leadership. (2 credits)

AU008 - The Function of the State

The analysis of the different roles that the state can play in the actions of urban and architectural intervention is introduced, in entrepreneurial, financial, encouraging or regulating role, and the consequential relationships with the private sector. In the same way, the subject will discuss the responsibilities of the professional in relation to the functions of the State in the urban and architectural operation. (3 credits)

FP092- Methodology of Scientific Research

This subject presents the stages of the research process and its techniques, so that the student takes a closer look at the scientific method, and so ease their contribution within their chosen field. (3 credits)

FMP/Practicum

Although the Practicum and the Final Draft are collected separately in the program, both are two different phases of the same process that culminates in the presentation of a single work. Broadly speaking, the process consists in the student selecting a topic of study that specially interests them, and proceeding to the creation of a monographic work. The Practicum part would correspond to the phase of the study, analysis, or design field. (10 credits)

3.D. MASTER IN PROJECT DESIGN, ADMINISTRATION AND MANAGEMENT WITH A SPECIALTY IN INNOVATION AND PRODUCT

DD050 - Introduction to Projects

This subject introduces the student, within a theoretical framework and in a general way, to the concepts of a "Project", such as: project phases, project systems, collaborative work, and knowledge management for the project's success, as well as their designs. This is to establish a knowledge base conducive to the undertaking the the subjects that follow. (1 credit)

DD051 - Project System Design

Provides concepts related to the identification of the project scenario, the factors that condition its solutions, establishing the technical problem, the formulation of the objectives, the criteria used for evaluating the success of the project, as well as the identification and analysis of all the persons and things involved in the resolution of the problem, understood as a fundamental part in the trilogy of man - artificial system - environment. (2 credits)

DD052 - Analysis of Provision of Services

This subject develops, investigates and determines the conditions of supply and regularization between the customer needs and what science and engineering would provide as a solution, considering this solution as the project itself, requiring that we define the "desired" service to be obtained as a result. (2 credits)

DD053 - Functional Analysis of the Project

During the development of the present subject we seek to determine the technical functions and services to meet the project we are designing, by means of the service tree as a "conceptual tool", the proposed project system, the value analysis and quality in the design phase. (2 credits)

DD054 - Project Ergonomics

This subject deals with understanding the role of the people in their activities and its uses in the solution of a project and its relationship with other people and machines, for which it establishes a classification of users, security measures, etc. (2 credits)

DD055 - Project Security and Reliability

This subject covers topics related to understanding aspects of the safety and feasibility of a project solution contemplating its states of life, its life-cycle, at the system level and its components, including people, machines and their relationships. (2 credits)

DD056 - Environment in a Project

By studying the project's sustainability, eco-design, environmental impact and life cycle analysis, which are the topics to delve into this subject, we understand the environment of a project solution in their states of life, its life-cycle, and at the system level and its components. (2 credits)

DD057 - Project Specifications

This subject will allow us to learn in detail, specify and explain the operation, detail and constitution of the potential solution provided by a project. (2 credits)

DD058 - Project Draft Preparation

This subject, by means of such topics as tools for specification, documentation, and the development of the project proposal, will help us to understand the importance of management as an ulterior step in design and be able to generate a proposal for a viable and sustainable management. (3 credits)

DD070 - Introduction to Project Management

Management/project management is the administration of all the necessary resources for the development of the same, as this course introduces us into the topic in a general way and covers, among other things, the following topics: general concepts of project management and types of projects, phases of a project and project life cycle. (1 credit)

TR038 - Planning and Management of Projects

The planning and management of projects are closely linked, since it is impossible to think of management without planning it. For this it is necessary to bear in mind some concepts: developing the project plan and the control of its possible changes, definition, administration and planning of the project scope, and choose and apply the appropriate techniques to produce a plan of action. (3 credits)

AU010 - Integral Management of Design and Product

The management of design is the right path to travel for the company intending to create their product. This subject introduces us then, specifically to the management of design, or innovation and product management.

It should be noted that we will consider that design only exists if there is an innovative contribution, for which the word design and innovation will be worked at synonymously.

By working with concepts of innovation and to transit new scenarios from the same, the design management requires a very precise adjustment to reduce any risk. This setting is related to a certain extent with the work of adjustment, which should also be done in the product's management, because this being of tangible nature, must incorporate their management processes, among other things, the issue of the significance and perception of form. (2 credits)

DD073 - Project Monitoring and Control

Surely the job of monitoring and control should be one that requires a greater commitment, and this is why the subject is presented with general topics like: learning the fundamentals of project control and their tools and methodologies, all the way to the particular, like carrying out the control of human and technical resources to ensure compliance with time, quality and cost. (2 credits)

AU011 - Areas of Design Contextual Conditions and User Requirements

The work of the designer is obtained as a result of a product with a given a percentage of innovation, which may be tangible or intangible, depending on the area for this design.

For both cases, this product should respond to the "usability" needs of the user, to give an efficient response, but it must also meet certain requirements that have to do with the unconscious emotional enjoyment of the user.

These requirements are somewhat sensitive, conditioned by a social, cultural and market contexts that require a special analysis.

We should also never forget that the incorporation of an innovative product, can require changes of habit in its immediate context. (2 credits)

DD075 - Trust Management: Risk and Quality.

Trust management focuses mainly on evaluating and learning the fundamentals of quality in projects, and their tools and methodologies, learning how to plan, guarantee and control quality, and risk. (2 credits)

AU012 - Innovation as a Tool for Improvement and Product Value Contribution

The concept of innovation is not only linked with the creativity associated with the product, but has now invaded all areas of business, as well as all the stages that comprises the product and the project's life cycle.

This is due to the fact that the marked trend since more than a decade ago, is moving away from calculated planning and is getting closer to the training focusing in creativity for the solution of problems, because of the short time given to finding a solution to conflict situations.

Innovation, then is not only a tangible contribution but is a tool for improvement, and amounts to the value of the intangible.

While the value can be quantified for measurement with economic parameters, it is an invisible component that is only found in the user's imagination.

A highly innovative product may lack any value and so will not find the success for which it was developed. (2 credits)

AU013 - Product and the Environment

Based on the definition of a series of environmental concepts and basic socio-economics that are involved in the concept of sustainable development, it focuses on the relationship between product and environment, considering the environment as an entire medium surrounding the product, and which in addition, the product will become a part of.

In this subject, innovation plays a leading role as it should consider the environment, and the future impact that will result from the product, as the first condition for creativity. (2 credits)

DD077 - Project Communication

The issue involved in this subject deals with the "inward" and "outwards" communication of a project, toward the three levels of users, from the basic circuits of communication up to the more complex structures of strategic communication, where the image of the same compromises with the social ideal. (1 credit)

AU014 - Theory of the Object

This subject is intended to contribute to the conceptual aspect of understanding the configuration qualities of the object and its various levels of perception; understanding the object as a phenomenon of cultural creation.

Its objective is for the student to know and understand the qualities that distinguish a design object, which can be identified as factors or requirements through the study of the form and the conditions of perception of the object, as well as its value in use and functions. (1 credit)

DD076 - Management Without Distances

The subject introduces the concepts and techniques of e-Management, explaining the meaning, nature and scope of the management and administration of projects and businesses without distance. (1 credit)

DD044 - Public Speaking Techniques

This subject has an increasing role in project management since it trains managers with the skills for promoting projects and their products, so as to obtain investors or at least interest within the market. It covers knowledge on communication strategies, and knowing how best to define the characteristic elements of the project that will shape its image. (1 credit)

TR026 - Business Administration and Management

This subject introduces the student to the concepts and techniques of administration and business management. It covers topics from organizational theories, until the new organizational forms in the new economy, whether for service companies, technology companies, SMES and family businesses. (3 credits)

DD014 - Strategic Management and Planning

This subject establishes the tools needed for the strategic management and mastery of the strategic planning process as the first basic steps for the project director, moving through such necessary topics like the mission, vision and values, chain value, SWOT analysis, selecting the strategies and the Balance Scorecard. (3 credits)

AU015 - Relationship between Innovation, Creativity, Productivity, and Competitiveness

At present there are two pairs of components that are essential at the time of developing a project which will result in a product, and they are, innovation and creativity, which operate synonymously to a high degree, and productivity and competitiveness, which although are not synonymous, are dependent of one another.

At the same time there is a strong link in both directions between the two pairs, as on the one hand, competitiveness will depend to a high percentage on the degree of the product's innovation, and on the other hand productivity can condition the creativity of the same.

In parallel to the relationship of said pairs, each of the 4 areas of work relates to the other three independently. (2 credits)

AU016 - Product Design and the Agents of Technology Innovation

The advancement in technologies is not indifferent to the specialized projects in products of an innovative basis.

And this does not only happen in management processes or the development of the project, but the impact of technology has been extended to the designer, the horizon established by the possibilities of production.

This subject will then deal with how much technology, from a qualitative and quantitative aspect, has impacted the areas of product and innovation.

The area of the technologies affirms that with a correct use of them, all innovative product can be realized, as we turn to verify this. (2 credits)

DD068 - Knowledge Management and Organizational Learning

This subject presents the methodologies, tools and techniques associated with the management of knowledge and sets out in said way to achieve a sustainable strategy of organizational learning from the maturity models of knowledge management. (2 credits)

AU017 - Profit and Strategic Design

A design becomes profitable with the simple incorporation not only of its concept, but redirecting it to the practice, since the design should give solutions to situations of conflict and then meet "good tastes".

In other words, there is nothing to gain by making a product "beautiful" from the aesthetic point of view, if it is not functional. If functionality is achieved, then it will be profitable, and if this was pre-established then it will also be strategic.

This subject is precisely about this, to understand that the contribution of a design is to add social and even economic profitability, but if it is not understood as this then you will be wasting a high potential of the product innovation, which can even be potentially harmful.

We must not forget that when we speak of a product or object, we look at the perceptions that their own language (language of the product) entails and these must reach its destination and cause the pre-designed response. (3 credits)

FP092- Methodology of Scientific Research

This subject presents the stages of the research process and its techniques, so that the student takes a closer look at the scientific method, and so ease their contribution within their chosen field. (3 credits)

FMP/Practicum

Although the Practicum and the Final Draft are collected separately in the program, both are two different phases of the same process that culminates in the presentation of a single work. Broadly speaking, the process consists in the student selecting a topic of study that specially interests them, and proceeding to the creation of a monographic work. The Practicum part would correspond to the phase of the study, analysis, or design field. (10 credits)

4. DEPARTMENT OF ENVIRONMENT AND SUSTAINABILITY

4.A. MASTER IN ENVIRONMENTAL MANAGEMENT AND AUDITING

MA001 - Introduction to Sustainable Development

After an introductory chapter in which the definition of a series of basic environmental and social concepts involved in the concept of sustainable development is provided, it delves into the history and environmental problems caused by the environmental impacts of human activities. Also, policies and strategies for the future of the EU and Latin America and the Caribbean in relation to the environment are provided. (2 credits)

MA002 - Ecology

It is essential to understand the processes that govern the ecosystems in order to assess the impact of any polluting activity on the natural environment. In this sense, the course focuses on the study of the origin and mechanisms of the interactions of living organisms with each other and between themselves and the world. To do this the different ecological levels are differentiated: organisms, populations, communities and ecosystems. (1 credit)

MA003 - Water Treatment

A description of the major water uses (domestic, industrial and agricultural) influencing the adoption of a set of best practices and the scope for reusing, analyzing and the possibilities of strategies by physical, chemical and biological mediums. It also includes a chapter on advanced purification treatments, which often constitute the only possible treatment when it comes to removing a specific contaminant. (4 credits)

MA004 - Waste Management

The integrated management of solid waste is introduced from the strategy of minimization, reuse, recycling and energy recovery methods established by the European Union, involving the different types of existing waste: Municipal Solid Waste (MSW), Industrial Waste and Rural Waste. There is also review of the main guidelines established by legislation to classify and characterize a particular type of given waste. (4 credits)

MA005 - Atmospheric Pollution

The chemical composition and structure of the atmosphere is studied, as well as the origin and determinants of pollution. Also, the impact on the chemistry of air pollutants, their dispersion in the atmosphere and the effects on the environment, are also studied. Finally, they are explained in detail the sampling and analysis procedures and the corrective or end-of-line measures used to comply with the current legislation in terms of particle or gas emissions to the atmosphere. (3 credits)

MA006- Climatology and Environment

Experience shows that the type of weather condition in addition to the fauna and flora of an area also influences the processes that affect air pollutants. This topic teaches the student to distinguish the various factors that determine the climate, the weather elements to measure, how to classify climates worldwide and at the regional level and their relationship to contaminants. For this, a widely studied case is used: climate change and its effects on the environment. (1 credit)

MA007 - Noise Pollution

Populations generate a series of noises associated with their activities (industries, automobiles, machines for domestic activities, etc.) which can become annoying to the ear, and even harmful to health. After completing this subject, students will learn the basic principles of acoustics and be able to prepare a noise impact study to quantify the damage to people and assess what corrective measures may be viable. (1 credit)

MA008 - Natural Resources

Thanks to their immense intellectual development and adaptability, humans have spread across the globe and the population has increased dramatically. Both circumstances have meant that humans are changing the natural environment incredibly quickly and drastically. This topic gives an overview of the current status and importance of the figures of protecting natural resources, whether renewable or not. (3 credits)

MA009 - Soil Pollution

From a very technical view, the study of the most common soil properties is performed, describing its main constituents, and distinguishing those of organic and inorganic nature. Also, a review of the degradation and soil contamination is performed, showing some of the soil remediation techniques. (3 credits)

MA010 - Business Environmental Management

They are provided in a very visual way and with a wealth of graphics, with guidelines for implementing an environmental management system in any company, according to the European International Standard ISO 14001 or EMS, including a case study that applies said knowledge on a metal fabrication company. (4 credits)

MA011 - Environmental Audit

This topic studies the common terms and concepts used when referring to the Environmental Audits (EMS). After learning this instrument of analysis of environmental management, its objectives and scope as well as the different types of audits are described. We also study the phases for carrying out an EMS and an audit manual is provided, which is a very useful tool for handling a large amount of information, so that students are able to generate their own files and adapt them to each specific case. (2 credits)

MA012 - Environmental Impact Assessment

A number of definitions needed to relate and quantify, within the current legislation, different impacts which may have an activity on the environment, the different classifications of impacts based on several criteria and according to the characteristic ratios are provided, the most common methods that allow the study of possible environmental changes and finally, references for the administrative procedures to follow for an environmental impact statement. (3 credits)

MA013 - Economy and the Environment

After studying the concepts on which neoclassical economics and ecological economics are based on, a review of externalities or external effects caused by economic agents as well as the theoretical and the tools used to internalize the externalities. Finally, the direct and indirect methods of economic assessment for the environment are described. (1 credit)

MA014 - Environmental Law

The emergence of environmental problems in the social environment and the scientific world has meant different legal aspects reoriented towards environmental aspects. This course takes an overview of the origins of said law and guiding principles, both European and Latin America. (1 credit)

MA316 - Dynamic Earth

It is an introduction to basic concepts of geological oceanography that explains both the birth of the oceans as the geological structure thereof. This requires a review of the characteristics that describe the geology of the seabed and major theories of global tectonics and continental drifts. (2 credits)

MA028 - Coastline and Marine Erosion

After studying all the types of coasts that comprise a coastline, the erosion and sedimentary processes that occur in them is shown. Thus, it seeks to highlight the function of coasts as dynamic physical systems, through the surf, as they are shaped in different coastal forms. (2 credits)

MA318 - Marine Sediments and Glacial Influence of the Seas

Description of the different types of marine sediments and sedimentary rocks derived from them. In addition, the subject includes a comprehensive review of the characteristics of sea ice, and the main formations which make them up. (2 credits)

MA019 - Installations and waste water filter treatment

A description of the major water uses (domestic, industrial and agricultural) influencing the adoption of a set of best practices and the scope for reusing, analyzing and the possibilities of strategies by physical, chemical and biological mediums. It also includes a chapter on advanced purification treatments, which often constitute the only possible treatment when it comes to removing a specific contaminant. (7 credits)

MA092 – Fundamentals of Environmental Engineering

In this course an overview is studied about the environmental problems that characterize today's society, and the role of environmental engineering as protective of the environment, which should be based on normative, sociological and economic aspects in order to meet its mission. Also, an introduction to pollution is made from the chemical point of view and the tools of environmental management are studied as a preliminary step for the sustainability of the processes. (7 credits)

MA108 - Fishery Exploitation

Introduction to the main characteristics of a fishing activity. It describes the different fishing resources, systems of fishing, fishing boats and activities related to the fisheries sector. (2 credits)

MA109 - Marine Culture

Study of the main characteristics of aquaculture production. It reviews the criteria needed to choose a type of crop compared to another, shows the different types of crops, studies the different phases of a comprehensive cultivation and describes the technical characteristics of cropping systems. (2 credits)

MA110 - Navigation and Marine Transportation

This subject reviews the history of navigation and the vicissitudes of current navigation, recapping the evolution of naval technology. It will also study the various techniques of immersion used today. (2 credits)

MA111 - Mineral and Energy Resources

Through this subject the student will learn about both the nature of the mineral resources present in the seabed, as well as the issues relating to its removal. In addition, it also presents the various energy possibilities currently offered by the marine environment. (2 credits)

MA102 - Basic Marine Ecology

Introduction to biological oceanography. Explains the basic concepts of marine ecology, which will serve as a basis for the subsequent subjects of a fundamentally biological nature. (1 credit)

MA103 - Marine Culture

Gives a comprehensive description of the groups of organisms that inhabit the oceans and seas around the world. The plankton, nekton and benthos organisms are all examined for this objective, and the critical strategies of each of these groups of organisms are demonstrated. (2 credits)

MA104 - Marine Communities

Explanation of the ecological relations existing between the various groups of organisms according to the marine habitats where they live. It will review the benthic coastal communities, subtidal communities, tropical coastal communities, the communities that live in the sand, the communities of estuaries and marshes and, finally, the communities that inhabit the ocean depths. (3 credits)

MA105 - Sea Water

Review of the physical-chemical characteristics that make it possible to classify the different water masses of seas and oceans of the world. This is an introductory course to chemical oceanography through which the student may assimilate the parameters that are usually measured in any oceanographic research. (2 credits)

MA106 - Water Circulation

The aim of this subject is to introduce the student to the fundamentals that drive physical oceanography. This explains the origin of the forces involved in currents and other oceanographic and atmospheric phenomena such as waves, and El Niño. It will also review the major ocean currents, the energy balance of the seas and the hydrological cycle. (2 credits)

MA107 - Sea Water Chemistry

This subject aims, on the one hand, for the student to know the processes that control the dissolution of gases in oceans and, on the other hand, to learn the major cycles of nutrients present in sea water and its close relationship with the various marine organisms. (2 credits)

MA249 - Analysis of Product Lifecycle and Carbon Footprint

The analysis of the Life Cycle and particularly calculating the carbon footprint, is studied as a comparative tool for the environmental benefits of a product, from raw material to its use as a waste.

Definition of LCA. Methodology of LCA. Analysis of impacts: Eco-points. Example: Application of LCA to packaging. Actions in the design of packaging and products in favor waste reduction. Implementation strategies in the business sector of environmental improvements in packaging. The European Ecolabel. Certification. The standard BS PAS 2050:2008. Calculation of Carbon Footprint: associated with raw materials, suppliers and related to production. (3 credits)

MA015 - Introduction to Project Management:

After evidencing the importance of water on Earth and in the natural ecosystems, a detailed description is done of the consumptive use and the availability of water supply for domestic, agriculture and industrial purposes. (2 credits)

MA016 - The Water Cycle

In this subject, the natural balance of water in the planet is covered, detailing the different types of continental and marine waters involved in this process. (2 credits)

MA017 - Water Management

Domestic and industrial (textile, skin cure, paper, chemical, etc.) water management is analyzed, delving in the sanitary systems and depuration of waters, and establishing saving measures and ecological criteria in the policies to be adopted. (3 credits)

MA018 - Water Analysis and Characterization

The analysis and specification of physical-chemical and biological properties are fundamental to understanding the quality and final destination of the waters once they are purified. In effect, through these techniques, we can study the environmental impact of water discharged in the aquatic environment, if we comply with the current legislation or if the concentration of nutrients is adequate. (3 credits)

MA021 - Water and Environmental Education

Methodological and teaching tools are presented to carry out environmental education regarding the integral management of water at the school level, as well as to the adult population. (0 credits)

MA029 - Facilities and Water Treatment

An exhaustive description is done of the sequence of treatments that water suffers since its entrance to the treatment plant until it's depurated, depending on the equivalent population, the typology of the receptor channel, and according to the criteria established by the legislation in force. The treatment of sludge generated in the process of subsequent application or its elimination to a controlled tank is also detailed. (10 credits)

MA081 - Urban Solid Waste

The following topics are discussed: Production of urban solid waste. Characterization of urban solid waste. Integral management of urban solid waste. Future tendencies in the management of urban solid waste. (7 credits)

MA082 - Industrial Waste

The following topics are discussed: The nature of industrial waste. Classification of industrial waste. Alternatives for the management of industrial waste. Recycling of industrial waste. Container and container residues. Tendencies in the management of industrial waste. (6 credits)

MA083 - Rural Waste

The subject discusses agricultural and livestock waste: purine and its material and energy valuation. (3 credits)

MA084 - Sanitary Waste

This subject emphasizes the importance of good sanitary waste management in the interest of public health and the environment, using laboratory waste management as a specific case. (4 credits)

MA085 - Environment Education and the MSW

Tools of promotion and participation. Public campaigns of awareness. Environmental education for adults and the school. Environmental guide to reduce MSW in a municipality; the problem of waste and practical advice to reduce waste. (0 credits)

MA057 - Introduction to Renewable Energies

A chronological review of the use of energy is done, defining the main forms of energy that exist and the natural renewable and non-renewable energy resources. In the same way, the main environmental impacts associated to the use of energy and the policies and energy programs, the current energy scope and the future perspectives are profoundly analyzed. (3 credits)

MA059 - Solar Thermal Energy

After studying the main parameters characteristic of the Sun and the basic notions of astronomy and solar positioning, we go in depth in the different systems of use: active and passive. In the other hand, the necessary equipment and requirements to perform and facilities of ACS, acclimatization of pools and radiant soil, are presented in an didactic and simple manner. (3 credits)

MA060 - Photovoltaic Solar Energy

Studies the fundamentals of photovoltaic conversion and the different components that comprise an installation of this type. Examples are also provided of the design, maintenance, assembling, costs and operation of a photovoltaic facility in a permanent or weekend house. (3 credits)

MA061 - Hydraulic Energy

After a brief exposition of the historical evolution of the use of water, we describe in a high technical scope and with application examples of the civil work involved, the criteria of the design of the water turbine, the costs and maintenance, etc. On the other hand, the environmental impact associated with the construction of a reservoir is profoundly detailed, as well as the current situation and future perspective of this type of energy. (3 credits)

MA062 - Wind Energy

The design and calculation of the wind potential of a wind turbine is presented in a theory-practical way, describing the best location, costs and more adequate types of turbines in the implementation of a wind park. The environmental alternations produced, and the current situation and future perspective of this renewable energy source are also detailed. (3 credits)

MA063 - Geothermal Energy

The main geothermic superficial expressions are described, as well as the types of deposit sites, pointing out the different domestic and agriculture applications. Equally, a description of the associated environmental impact is done, and of current and future geothermic energy. (1 credit)

MA064 - Biomass Energy

A description is done of the different applications of the biomass, with energy or material purposes, providing in the first case the transformation processes of biomass in energy with a multitude of installation examples. We likewise make reference to the environmental vectors affected in its energy use and the future possibilities of development. (2 credits)

MA065 - Sea Energy

The physical principals that rule the tides, the energy of the waves and the oceanic thermal energy, pointing out in each of them its potential, economic viability, environmental impact and future perspective. (2 credits)

MA073 - Natural Areas in the Context of Societies

As an introduction, we chronologically review the relationship of man and nature, influencing in the socioeconomic factors that impact the management of the natural media. Regarding this, the main conservation entities are identified, as well as the agreements, the treaties and the policies currently employed in nature protection. (2 credits)

MA074 - Biodiversity

Biodiversity is a necessary tool for natural space management. It is therefore necessary to explain biodiversity and its importance within a natural system, what tools exist for quantifying it and, lastly, to know how to interpret the meaning of the changes that occur. (3 credits)

MA075 - Natural Spaces: Typology and Processes

The use and interest in establishing a classification of the natural spaces is undeniable because it supposes the knowledge of great similarities in Earth over small differences. This way, we establish the criteria to identify the coincident aspects among these natural areas that allow its classification. The ecological processes of nature that have been revealed as essential for the preservation of the biological diversity and the conservation of natural spaces, are also profoundly covered. (3 credits)

MA076 - Uses of Natural Spaces

We intend to demonstrate the uses and activities carried out by humanity in natural spaces, introducing concepts regarding the use of land and the exploitation of ecosystems. Analogically, an exhaustive review is done of the different models of land use and the main motors of change through humanity's history. (3 credits)

MA077 - The Conservation of Species and Natural Areas

The conservation of nature is a process of maintaining natural resources that involve biological, economic, political, social and anthropological factors. Based on these aspects, the different strategies of conservation adopted nationally and internationally are characterized, and the priorities that a global strategy must have to achieve maximum efficiency. (3 credits)

MA078 - Management of Natural Spaces

The basic principles of good management of conservation are broadly explained in this section, as well as the sustainable management methods of a natural area. Therefore, it is necessary to explain the profile that the manager must have and their role in making decisions and in the resolution of conflicts. It also exposes the need and methodology of monitoring the natural space. (4 credits)

MA079 - Ecologic Restoration and Landscaping

In this section the necessary knowledge is acquired in a practical and simple way, to draw conclusion towards the sustainable restoration of a perturbed environment. Regarding this, the criteria will be established that will be applied in the selection of the final use of the zone to be restored, the selections of the restoration method and the restoration material and finally the design of the phases of the restorative process, without forgetting the landscaping criteria. (2 credits)

MA080 - Case studies of Management and Conservation of Natural Spaces

Compilation of current practical examples concerning the process of planning the management and conservation of a natural area, incorporating the concepts of ecological restoration in the event that the environment is altered due to construction or some activity in the area. (0 credits)

MA087 - Evolution of the Environment and Sustainable Development

The philosophical foundations of environmental thinking is introduced as a departure point to relate the environment with development and sustainability. Equally, it provides a series of principles that guide the education and environmental management action. (2 credits)

MA088 - Historical Evolution of Environmental Education

A review of the main milestones that have marked the evolution of the concept of environmental education for sixty years until now, influencing the doctrinal aspect of its proposals and difficulties. Key aspects are also covered, as culture and values from a social change perspective. (2 credits)

MA194 - Basic General Concepts of Environmental Education

A test of some theory, methodological, pedagogical, curricular and educational practice of environmental character, as well as the diverse orders that prevent the development of this practice. (2 credits)

MA195 – Environmental Education in Formal Education

Its purpose is that the team of professors in schools, through the analysis of their real pedagogical practice and explicit and implicit budgets that underlie the teaching action, identify the favorable and unfavorable elements for Environmental Education. (3 credits)

MA090 - Environmental Management and Sustainable Development

We make reference to the role of education in environmental management, especially related to urban and rural scopes, with the actions of land ordinance, and particularly with the municipal social-environment. (2 credits)

MA091- Risk Management and Environmental Education

Covers how development, in its predominant conception, has turned our species into a plague, and to understand the disasters as expressions of the disability of human communities to interact harmoniously with the dynamic of nature; and simultaneously, as expressions of the efforts of the immunological system or auto regulation system of the biosphere, to get rid of said plague. (2 credits)

MA243 - Management of Water Pollutants

Provides an introduction to the treatments that have a place in the physical-chemical and biological depuration of urban and industrial waters. It includes a practical example of dimensioning and calculation of a system of depuration of urban and industrial waters for an average size population. It also introduces the tools to evaluate, control and manage the quality of continental and regional waters. (4 credits)

MA136 - Marine Aquaculture Technology: Toward a Sustainable Aquaculture

We cover the common environmental aspects of any fish farm facility, analyzing the planning tools of the region and the current state of the technology that influences this sector. This way, the student will be able to identify the environmental aspects regarding fish farms and to propose current corrective measures to minimize the impact of this activity. (3 credits)

MA140 - Fisheries Management

In the study of this subject, the student will acquire a general vision of fisheries and will know the different factors that intervene in them, from the exploitation of the resource to the first sale in the market. The student will also learn to evaluate the state of a fishery, as well as how to establish the best corrective measures for the conservation of the resource from a biological and economic point of view. (3 credits)

MA139 - Management of Natural Marine Protected Areas

Establishes the natural, socio-economic and legislative criteria needed to perform a correct management of natural marine spaces with some protective features. The necessary knowledge for the design and the establishment of the localization of natural marine areas that must be protected are also detailed. (3 credits)

MA137 - Biological Pollution Management

The composition of the different plagues of species called "anti-economic" from a biological and social-economic point of view and the current follow up and control systems are shown. Besides, it presents the methodology of analysis of the biological quality of coastal waters. (4 credits)

MA098 – Business Environmental Management: ISO 14001

They are provided in a very visual way and with a wealth of graphics, with guidelines for implementing an environmental management system in any company, according to the European International Standard ISO 14001 or EMS, including a case study that applies said knowledge on a metal fabrication company. (7 credits)

MA028 - Potentially Contaminated Marine Ecosystems

The study of how marine ecosystems function is the foundation to evaluate the impacts that the biotic media of the ocean suffers. Following this premise, topics of great ecological interests are covered, from the classification of the organisms that live in our region, to the relationships between them. The natural parameters involved in the distribution of the organisms in our coasts are also identified. (2 credits)

MA029 - Environmental Factors that Affect Pollutants

In the heart of the ocean are a series of dynamic systems that condition the presence and concentration of anthropic contaminants. We must perform an approximation to these systems to understand their real impact. In essence, the physical processes that rule the circulation and diffusion of contaminants and the chemical reactions that take place in the media are outlined. (2 credits)

MA030 - Contaminating Agents

Mentions the polluting agents that alter the natural balance of the marine media. The main sources are particularly identified, the chemical forms in which it can appear, the main physical and biological processes that it suffers, its effects over organisms and marine communities, and the corrective measures that are applied, if they exist. The content covers the following topics: heavy metal, hydrocarbon, organochloride compounds, radioactivity, thermic contamination, exotic species and water waste. (2 credits)

MA031 - Toxicology

This section intends to respond the following questions: What happens when a contaminant comes in contact with an organism? How can we evaluate if a shore environment is contaminated by a specific polluting agent? To respond to these and other questions, a detailed description is done of the toxicological test that must be performed, the types of possible intoxications and the factors that affect toxicity. (1 credit)

MA014 - Recovery of Contaminated Soil

A review of the usual contaminants that are present in the soil, and the process and interactions that occur in its interior. At the same time, the subject offers a profound review of the necessary tools to perform the characterization of edaphic contamination, as well as the recovery technologies employed in the decontamination of soils and its subsequent follow up and control. (7 credits)

MA208 - Mining and the Environment

Covers the study of mining and its environmental repercussions from different points of view, assessing the impacts produced in all the phases of the activity under the current legislation. The rules to implement a Management System through the execution of a case study for a mining activity are also described. (13 credits)

MA245 - Agreements, Negotiations and Instruments for Climate Change

This subject provides the general governmental proposals, as well as the international negotiations and the financial performance up to the date, to develop actions that allow the adaptation and mitigation of climatic change in collaboration with the private sector, besides the promotion of institutional capacities, citizen awareness and education and training. (8 credits)

MA246 - Vulnerability and Adaptation to Climate Change

This part evidences that the problem of vulnerability and adaption to change not only depends on climatic conditions, but also in the social and economic conditions of the population, sector or region. It is necessary to pose the possibility that the measures or adaptation strategies are incorporated to the policies of each sector and the program of biodiversity, combating the decertification and reduction of poverty. In other words, to join efforts carried out in this diversity of policies to optimize and make the efforts accomplished coherent. (9 credits)

MA248 - Science and Politics of Climate Change

This part shows the interdependency between sciences and politics to face climatic change. Both concepts can be effectively insoluble and the government has the obligation of including standards and policies to develop actions that allow adaptation and mitigation, besides promoting institutional capacities, citizen awareness, education and capacitation. (7 credits)

MA282 - Climate Change Mitigation

Sectoral Climate Change Mitigation

Sector of residential, institutional and business buildings. Transportation sector. Industrial sector. Energy sector. Agricultural sector. Forest sector. Elimination of waste and residual waters.

Energy Resources

Global quantities, resources, potential and energy sources. Non-renewable energy sources. Sources of renewable energy.

Current and Future World Energy Scope

Evolution of the use of energy and the population. The energy balance. World energy scope. Use expectations of renewable energy.

The Current Context of Renewable Energies

Main criticism against renewable energy. Energy potential of renewable energy. Environmental impact of renewable energy. Policies of implementation of renewable energy. Wind energy. Thermic solar energy. Photovoltaic solar energy. Biomass energy Mini-hydroelectric energy.

Other Energy Conversion Processes from Organic Waste Fraction

Combustion/Incineration. Pyrolysis. Gasification. Anaerobic methanation or fermentation. Energy assessment of sewage sludge for WWTP. Degassing of controlled deposits.

Capture and Storage of Carbon from the Soil

CO₂ capture. Production and estimated costs. CO₂ transportation. CO₂ storage technology

Secondary Residential Wastewater Treatment

Aerobic and anaerobic treatments. Principles of biological depuration. Natural biological treatments. Facility treatments. Other biological treatment systems.

Bioclimatic Architecture

Passive solar architecture. Construction criteria.

(8 credits)

MA093 – Engineering Recovery and Treatment of Waste

Presents the hierarchy in the management of waste. First, we study the selective collection as a homogenization method of waste, so when it is transported to the separation plant, they can feed directly into the treatment line of the sub-product that they contain. The diverse procedures of valuation are also explained in detail, such as composting, methanisation, pyrolysis, etc., and the controlled deposits or dumpyard. (13 credits)

MA039 - Industrial Wastewater Treatment

The characteristics of wastewaters are shown in detail, depending on the industrial activities generated (textile, paper, food, surface covering, among others) and the most adequate treatments for each particular case. In this sense, it is intended that the student learns to apply the best technology available for each type of water depending on its origin. (13 credits)

MA095 - Treatment of Gaseous Effluents

Describes the contaminants that can cause harmful effects to man and its environment, resulting mainly of employing combustible fossils in the generation of energy, heating systems and motor vehicles. The concepts of emission and immission of the contaminants are also enunciated, as well as the corrective measures enforced in industries, with the purpose that the admissible quality levels are not to be exceeded during the time that the facility is functioning in normal conditions. (7 credits)

MA143 – Energy Recovery

In the context of an integral solution of waste assessment, energy recovery performs an important role. In this Program, the main processes of energy assessment to obtain electricity from waste, which in other conditions, would be deposited in a dump yard, are all detailed. It also describes the main "alternative" or "renewable" energy sources and provides an exhaustive and easily understandable review with many example diagrams of the cogeneration system as a process used and accepted for combined heat and power production. (7 credits)

MA014 - Recovery of Contaminated Soil

A review of the usual contaminants that are present in the soil, and the process and interactions that occur in its interior. At the same time, the subject offers a profound review of the necessary tools to perform the characterization of edaphic contamination, as well as the recovery technologies employed in the decontamination of soils and its subsequent follow up and control. (7 credits)

FP092- Methodology of Scientific Research

This subject presents the stages of the research process and its techniques, so that the student takes a closer look at the scientific method, and so ease their contribution within their chosen field. (3 credits)

TFC

Broadly speaking, the process consists in the student selecting a topic of study that specially interests them, and proceeding to the creation of a monographic work. (10 credits)

5. DEPARTMENT OF HEALTH SCIENCES

5.A. MASTER IN PHYSICAL ACTIVITY: SPORTS TRAINING AND MANAGEMENT

SN039 - Structure and Function of the Human Body

Studies the basics of human anatomy and physiology. (3 credits)

SN155 - Contextualization of Physical Activity and Exercise in the Health Framework

Studies the historical development of physical activity in relation to health and lifestyles. The study of the importance of physical activity in relation to various pathologies. (3 credits)

SN156 - Psychosocial Aspects of Physical Activity for Health

The study of the influence of psychological and social factors in the performance of physical activity. (4 credits)

SN157 - Control and Prescription of the Physical Activity

Studies the general principles of prescribing physical activity and its evolution. (3 credits)

SN158 - Physical Activity for Health in Different Diseases

The study of the relationship between physical activity and diseases of high prevalence. (4 credits)

SN159 - Physical Activity in Children and Teenagers

The study of sports physiology in children and adolescents. (3 credits)

SN160 - Physical Activity in Seniors

Study on the importance of physical activity in older adults. (4 credits)

SN198 - Basic Aspects of Nutrition

Study of the basic biochemical of glucides, proteins, lipids, vitamins and minerals with an emphasis in the hydric balance. (Pre-requirement for SN217-Nutrition and Sports)

SN048 - Training Theory and Practice

Basic aspects of the processes of training and adaptation to exercise endurance and speed. Incorporates the learning and technical-tactical development of the athlete. (4 credits)

SN049 - Sports Planning

Learn to develop workout plans, implementation and evaluation of the results. (4 credits)

SN050 - Sport Psychology

Studies the psychological factors present in the participation and athletic performance, exercise and other physical activity. (3 credits)

SN042 - Kinanthropometry

The study of the human body by anthropometric measurements and evaluations in order to understand the processes involved in growth, exercise, nutrition and athletic performance. (3 credits)

SN217 - Nutrition and Sport

The study of sports physiology, the metabolism of different macronutrients, the importance of proper hydration, ergogenic aids, among others, which shall then be applied to making the meal preparations for each type of sport (aerobic or anaerobic). (3 credits)

SN047 - Eating Disorders in Sports

The study of what these are, how they are diagnosed, dietary treatment to be applied, secondary complications, psychotherapeutic and psychopharmacological treatment. Knowing what the evolution, prognosis and prevention will be. (3 credits)

SN043 - Ergogenic Aids

The study of the influence of fatigue in athletes and how it can be improved. (3 credits)

DP004 - Management Techniques for Sports Teams

It covers general aspects of leadership and conscious and systematic influence on the group and an individual during a given activity. (2 credits)

SN228 - Study and Case Resolution for Sports Training

Find the mastery and application by students of concepts learned in the Masters. It does not have a predefined format as the students are expected to have freedom when choosing the theme and content.

The objective is to demonstrate that the student has the ability to take one (or more) i professional fields, subjects, the mastery or the space of knowledge at the Master' level. The case may be used as the basis for the Final Project to be completed later while its content shall be defined by mutual agreement between the tutor and student. (4 credits)

DP001 - Administration and Management of Sport Entities

Study of the functions that a director of sport organizations must serve, and the legal basis governing the sport internationally. (3 credits)

DP002 - Strategic Management and Planning of Sport Organizations

Enables the understanding and implementation of strategic planning in organizations and sports entities focusing on their strengths and weaknesses to achieve the goals and objectives. (3 credits)

DP003 - Sports Marketing. Applications

The study of tools for the collection, satisfaction of customer loyalty, profitability and positioning of a sports entity or organization, and understanding the meaning, nature and scope of the marketing function in sport. (3 credits)

DD1021 - Strategic Management of Human Resources

The study of organizational behavior with emphasis on the behavior and motivation of people and their interaction with the environment. (2 credits)

DP004 - Management Techniques for Sports Teams

It covers general aspects of leadership and conscious and systematic influence on the group and an individual during a given activity. (2 credits)

DP006 - Techniques for Management and Leadership in Sports

The study of techniques and behavioral process that influences the behavior of athletes to obtain satisfactory results. (2 credits)

DP007 - Society of Sport and Information

Sociocultural analysis model that currently exists, characterized by sharing information, eliminating distance and time thanks to social media and technology. (3 credits)

SN048 - Training Theory and Practice

Input on the fundamental principles associated with performance improvement in the bodily quality of physical and sports activities. (4 credits)

SN229 - Study and Case Resolution for Sports Skills

Find the mastery and application by students of concepts learned in the Masters. It does not have a predefined format as the students are expected to have freedom when choosing the theme and content.

The objective is to demonstrate that the student has the ability to take one (or more) i professional fields, subjects, the mastery or the space of knowledge at the Master' level. The case may be used as the basis for the Final Project to be completed later while its content shall be defined by mutual agreement between the tutor and student. (4 credits)

FP092- Methodology of Scientific Research

This subject presents the stages of the research process and its techniques, so that the student takes a closer look at the scientific method, and so ease their contribution within their chosen field. (3 credits)

FMP/Practicum

Although the Practicum and the Final Draft are collected separately in the program, both are two different phases of the same process that culminates in the presentation of a single work. Broadly speaking, the process consists in the student selecting a topic of study that specially interests them, and proceeding to the creation of a monographic work. The Practicum part would correspond to the phase of the study, analysis, or design field. (10 credits)

5.B. MASTER IN NATUROPATHIC SCIENCES – ACUPUNCTURE

SN259 - Human Anatomy and Physiology

The Human Anatomy and Physiology subject analyzes the different anatomical structures of the human body and its corporal functions, as well as its homeostatic regulation.

The subject provides knowledge on the main fundamentals of the body's structure, organization and functioning. It comprises the disciplines of human anatomy and physiology. The integration of both disciplines is aimed at understanding the different parts of a cell, the association of numerous cells within a tissue, the set of tissues that create an organ, up to what the systems and apparatus's of the human body are and function. (6 credits)

SN260 - Organic Chemistry

The Organic Chemistry subject is added so as to achieve a greater overview of the concepts, principles and bases that make up the field of organic chemistry.

The subject introduces the structures, properties and reactions of organic substances that are also present in the human body.

It shows the student the fundamental bases of organic chemistry, beginning with simple structures and progressing toward the more complex of these. (6 credits)

FP092- Methodology of Scientific Research

The Methodology of Scientific Research subject examines the stages and techniques of scientific research, the variable analysis, the guidelines for organizing the data and the development of logical reasoning for comparing communities.

The subject presents the stages of the research process and its techniques, with the purpose that the student be a rapprochement with the scientific method and provide him with generate contributions within their field of work. (3 credits)

SN028 - History of Biological-Naturist Medicine

The History of Biological-Naturist Medicine is included with the purpose of examining past historical concepts to understand the Biological-Naturist Medicine of today as well as the past philosophical foundations to delve into Traditional Chinese Medicine.

It is a display of past medicine schools from around the world. The sequence of studies covers the medicine from, old India (Ayurveda), the medical tradition of Egypt, the old Mesopotamia, the Greek medicine schools, Pre-socratic and Pre-Columbian American, to the naturopathics of the XX and XXI centuries. It also examines primitive man and progresses through the Shany-Yin Dynasty, Zhou Dynasty, the era of the Three Kingdoms, Xi Jin and Hou Jin Dynasties, Sui, Táng and Wudài Dynasties, Sòng and Míng Dynasties, up to nowadays. (3 credits)

SN086 - Biological Vision of Organ Dysfunction

It incorporates the subject of biological vision of organ dysfunction with the purpose of providing an overview of the disease, its alterations, the most common health disorders and their relationship with the different organ systems, regulation of acid-base system and the role of the toxins in the organ dysfunction.

Shows the student a biological vision of organ dysfunction from the perspective of the disease as one pathological unit. Besides, it emphasizes in the importance of the basal metabolism, the electrolytic balance, the homo-toxins and the role of detoxification in correcting organ dysfunction. (3 credits)

SN017 - Nutritional Biochemistry

The subject of Nutritional Biochemistry is incorporate to provide a scientific approach to the metabolism of nutrients by describing its function at the cellular and molecular level with emphasis on the metabolic pathways, the enzymology and the regulation of metabolism. It also analyzes the cell signaling, regulation of gene expression and the destination of the macro-nutrients.

Covers in detail the study of cell signaling and the gene expression in the regulation of the metabolism. Besides, it emphasizes in the metabolic destiny of carbohydrates, lipids, and amino acids. (3 credits)

SN018 - Evaluation of the Nutritional State

The subject of Evaluation of the Nutritional State with the purpose of deepening in the different techniques to determine food and nutrients ingestion (food survey) and the techniques to evaluate the nutritional state (anthropometry and body composition).

It focuses primarily in the evaluation of the nutritional state of the individual or population, paying special attention to areas of determination of food and nutrient ingestion through the use of scientific surveys of food; introduces students to the main tools of nutritional state evaluation. (3 credits)

SN101 – Acupuncture, Homeopathic and Naturalism Constitutional Types

The subject of constitutional types in acupuncture, homeopathy and naturalism covers the different constitutional types in which the individual has been classified through the history of the medicine.

Study of the constitutional types in conventional medicine, acupuncture, homeopathy and herbal medicine.. (3 credits)

SN087 - Naturist Diet and Dietary Sensibility

This course focuses particularly on the description of the mechanisms that the human body uses to assimilate food nutrients, the alterations in intestinal permeability and the most outstanding nutritional theories, following an approach strictly hygienist and/or naturist. (3 credits)

SN136 - Electroacupuncture of Voll and Bioresonance

This subject has the purpose of providing the naturopathic sciences student efficient diagnostic methods that will allow for a more effective causal treatment of diseases.

Students will study the and compare the electroacupuncture of Voll with the Chinese Acupuncture, know what Bioresonance is, its applications and uses. (3 credits)

MN012 - Nutrition in Common Diseases

The subject of Nutrition in Common Diseases has the objective of examining the factors that influence the development of certain diseases such as obesity, diabetes, hypertension, atherosclerosis, osteoporosis, cancer, oral conditions, constipation and alcoholism; in addition to the dietary recommendations to prevent or treat these diseases. In addition, it considers the contributions of balanced nutrition in the prevention and treatment of these pathologies. (3 credits)

SN094 - Anti-aging Therapy and Free Radicals

This subject covers the main theories on aging, genetic and hormonal influence, the role of free radicals and antioxidants, environmental toxins, diet, detoxification and longevity.

It focuses in the effects of premature aging caused overall by oxidative stress. Besides, it provides competencies that allow the naturopathic professional to apply anti aging therapies looking to delay or revert physiological damages. (3 credits)

SN096 - Orthomolecular Therapy and Trace Elements

The subject of Orthomolecular Therapy and Trace Elements has the objective of providing knowledge about the role of vitamins, minerals and trace elements with health.

The purpose is to do a review of the trace elements and provide a global vision and practice of orthomolecular therapy for their correct application. (3 credits)

SN099 - Colon Hydrotherapy

This course has the objective of evaluating the colon hydrotherapy methodology, its use through the years and the physiological concepts of its application. (3 credits)

SN011 - Phytotherapy

This subject helps the student delve into the scientific analysis of the phytotherapy and trends, the active principles of plants, their mechanisms of action, its Galenic preparation, and its implementation and potential phytotherapeutic.

It focuses particularly on the study of plants with therapeutic purposes, and pays special attention to the identification of different varieties of medicinal plants, collection, storage, active principles, mechanisms of action and proper use of the preparations. (3 credits)

SN088 - Aromatherapy

The subject of Aromatherapy is presented to review the implementation of the volatile oils of certain plants as a method for promoting health in mood and physical processes.

Concentrates on the study of essential oils of certain plants, its extraction, most appropriate Galenic forms and its main routes of administration. (3 credits)

MTC001 - Basic Theory (Part I)

The subject Basic Theory (Part I) has the purpose of introducing the student to Traditional Chinese Medicine through the study of specific theories and clinical reality, vital substances, organs and functional spheres.

This way the student learns progressively the basic medical concepts of the past and their relation, influence and reciprocity with modern concepts. (3 credits)

MTC002 - Basic Theory (Part II)

Basic Theory (Part II) delves into Traditional Chinese Medicine through three fundamental concepts: meridians, etiology and physiopathology.

Presents another fundamental and proper concept of Chinese Medicine: the meridians or preferred via of fundamental substances circulation, especially of "Qi". (3 credits)

MTC003 - Diagnostic

This subject deepens in the protocol to be followed in the two stages of the process of diagnosis in Chinese Medicine: the collection of data and the analysis and interpretation, using observation, testing, development and heartbeat or pulse.

It is a subject of great importance, as as diagnostic is presented as the method of collection of data that allows the clinical professional with specialty in Traditional Chinese Medicine propose the most appropriate treatment based on the diagnosis established. (3 credits)

MTC007- Differentiation of Syndromes

This subject covers the concepts of methodology, identification and differentiation of syndromes.

Shows the methodology to identify and differentiate syndromes according to the eight principles, the Qi, the etiology, the five elements, meridians and organs. (3 credits)

MTC008 - MTC Therapeutic

This subject covers prevention, treatment and clinical history in MTC.

Shows the student how to prevent a disease before it occurs and to cure the diseases from the root using various methods of treatment and classical prescriptions of Traditional Chinese Medicine. It

also emphasizes the importance of the clinical history and highlights the most important aspects and points to take into account during its preparation. (3 credits)

MTC009 - Auriculartherapy

The student will be introduced to auriculotherapy through its history, its different theories, the atrial anatomy, their diagnostic tools and treatment techniques.

It focuses on the individual and detailed study of Ear Acupuncture, or method to diagnose and treat the human body through the pinna. (3 credits)

MTC010 - Meridian and Points (Part I)

This subject has the purpose of developing the theme of the meridians and acupuncture points.

Shows the concept, the classification, nomenclature, general actions and methods of location of the acupuncture points. (3 credits)

MTC011 - Meridian and Points (Part II)

This subject has the purpose of developing the theme of the meridians and acupuncture points.

Shows the specific points, localization and energetic functions of the diverse meridians of the organism. (3 credits)

MTC012 - Acupuncture Techniques

This subject develops the various acupuncture techniques such as moxibustion, cupping, microbleeding, cutaneous acupuncture and intradermal acupuncture and scalp acupuncture , electro-acupoint stimulation and laser.

Show students the basic protocol to use these techniques. (3 credits)

MTC013 - Acupuncture - Internal Medicine

This subject develops the principles and protocols of acupuncture directly related to Internal Medicine and its pathologies.

Shows the student the pathophysiology and treatment with acupuncture and moxibustion of cardiorespiratory, gastrointestinal, nervous system, psycho-emotional and genitourinary tract diseases. (3 credits)

MTC014 - Acupuncture - Specialties

The subject Acupuncture - Specialties has the purpose of introducing the strategies of treatment with acupuncture and moxibustion of gynecological and pediatric diseases and eye and skin disorders.

Shows students the physiopathology and the treatment with acupuncture and moxibustion of the different pathologies. (3 credits)

MTC016- Pharmacopoeia 1

Pharmacopoeia 1 has the objective of developing the medical material of Chinese Traditional Medicine and its material.

Shows students the different therapeutic practices done through history regarding energetics and its evolution. In addition, the subject covers the fabrication methods and the therapeutic utilities in Chinese Traditional Medicine. (3 credits)

MTC017- Pharmacopoeia 2

Pharmacopoeia 2 has the objective of developing the medical material of Chinese Traditional Medicine and its material.

Shows students the different therapeutic practices done through history regarding energetics and its evolution. In addition, the subject covers the fabrication methods and the therapeutic utilities in Chinese Traditional Medicine. In addition, identifies the most usual Energetic Supplements in Chinese Therapy. (3 credits)

MTC018 - Prescription

This subject has the objective of developing the medical material of Chinese Traditional Medicine y the analysis of its formulas.

Shows the student a brief introduction about the history and importance of the prescription in Traditional Chinese Medicine and deepens in formulas that release the surface, which release heat, that are laxatives, which harmonize, that expel moisture, which transform the Tan, that heat the interior, which invigorate and regulate the Qi. (3 credits)

MTC019 - Phytotherapy Treatment (MI)

This subject has the purpose of developing the phytotherapy treatments of pathologies.

Shows the student the phytotherapeutic treatment of several diseases such as colds, coughs, asthma, heart palpitations, insomnia, depression, gastralgia, Abdominalgia, diarrhea, dysentery, jaundice, vomiting, constipation, diabetes, hemorrhage, edema, ACVA, syncope, headache, dizziness, low back pain, among others. (3 credits)

MTC020 - Dietetics in Traditional Chinese Medicine

This subject covers the dietetic treatment according to Traditional Chinese Medicine.

Shows the student the general concepts of the traditional Chinese dietetic, identifying the characteristics of food, preparation techniques and dietetic treatment according to the syndromes. (3 credits)

MN005 - Homeopathic Basics and Principles

This subject has the purpose of going into details in the history of homeopathy, the bases of the homeopathic pharmacopoeia and its methodology.

The student shows a profile of the history of homeopathy, the principles governing the organization, the concept of hierarchization of symptoms, and prescription methods that extend the field of action of homeopathy as a therapeutic modality. (3 credits)

MN006 - Homeopathic Method Application

The Homeopathic Method Application subject aims to evaluate homeopathic therapy in acute disease and chronic disease.

It focuses on the study of the homeopathic therapy in the acute and chronic pathology, main medicines, considerations on consultation and therapeutic options. (3 credits)

MN007 - Medical Homeopathic Material

This subject assists the student in developing an individual study and analysis of the most commonly used homeopathic medicines.

It focuses on the individual and detailed study of the most commonly used homeopathic medicines using as reference the Medical Homeopathic Material. (3 credits)

MN016 - Homeopathic Therapy in Acute Diseases

This subject has the purpose of examining in detail the homeopathic therapeutics in the acute disease, homeopathic drugs used with success in the medical practice in different disorders depending on the stage of the disease and the affected body system.

It focuses on the homeopathic set of protocols for acute pathologies; paying particular attention to remedies that, based on clinical experience, the homeopath has used with success depending on the stage of the disease, and the organs affected. (3 credits)

MN017- Homeopathic Therapy in Chronic Diseases

This subject has the purpose of examining in detail the homeopathic therapeutics in chronic disease, homeopathic drugs used with success in the medical practice in different disorders depending on the stage of the disease and the affected body system.

It focuses on the homeopathic set of protocols for acute pathologies; paying particular attention to remedies that, based on clinical experience, the homeopath has used with success depending on the stage of the disease, and the organs affected. (3 credits)

SN098 - Kousmine Method

This subject analyzes the method used by Dr. Kousmine and her five supporting pillars.

It is a subject of great importance, as it introduces the naturopathics science student in the study of a method oriented toward both the prevention and treatment of chronic and degenerative diseases.
(3 credits)

SN102 - Homeopathy and Homotoxicology

This subject has the objective of examining the principles of the homeopathy and the homotoxicology therapy methods, and determine the different forms that they can be applied.

Homeopathy is studied through its history to understand its principles, define the health and the healthy individual, categorize the types of energy, analyze the value of symptoms to establish a diagnosis, develop the recipe, guide administration of medication, treat chronic diseases and to know the biological action of the toxins in the body. (3 credits)

SN103 - Sophrology

This subject introduces the naturopathic science student in the revision of the human consciousness, as well as the mechanisms susceptible to modify it with therapeutic or prophylactic purposes.

Study of Sofrología and its applications, its objectives and principles, the phenomenology, consciousness and “terpnos logos”. (3 credits)

SN105 – Spagyria

This subject has the purpose of deepening in the history, evolution and basic principles on which is based the therapeutic system Spagyria.

Study of the spagyric medicine, its principles, origin, evolution, preparation of drugs and methodology.
(3 credits)

SN097 - Neural Therapy and Neurofocality

This subject is offered with the objective of reviewing a therapeutic method based on the use of local anesthetics with therapeutic and diagnostic purposes; to know their history and understand how the system works and its importance for these medical practices. (3 credits)

MN014 - Methods of Naturopathic Evaluations

The subject of Naturopathic Assessment Methods evaluates and measures adequately and objectively the field biological or internal health conditions of the human organism, using samples of hair, urine, saliva, and a few drops of blood, which facilitates the detection of biochemical, physiological requirements and nutritional needs of the patient.

It goes into details to various naturopathic evaluation methods. The Reams Biological Theory of Ionization (RBTI Analysis). Live Blood Microscopy and the Mineral Analysis of Tissue; in addition, the basic concepts of interpretation of conventional tests of blood from a strictly nutritional status. (3 credits)

MN015 - Massage, Reflexology and Kinesiology

It incorporates the subject of massage, reflexology and kinesiology with the purpose of providing the naturopathic science student of the knowledge and skills necessary to implement the various naturopathic therapeutic methods of such patterns themselves.

Introduces students to the study of the basic concepts and the practical skills related to the therapeutic application of the massage, reflexology and the kinesiology. (3 credits)

SN091 - Heliotherapy, Thalassotherapy, Mud Therapy and Aerotherapy

The subject of Heliotherapy, Thalassotherapy, Mud Therapy, Aerotherapy has the purpose of valuing the history of each one of these therapeutic modalities and guidelines for their implementation.

It special attention is given to the therapeutic applications of the Heliotherapy, Thalassotherapy, Mud Therapy, Aerotherapy (3 credits)

SN090 - Ozone-therapy

It incorporates the subject of Ozone Therapy to analyze in detail the ozone, ozone therapy, its biochemical action on the body, its application and toxicity.

This material focuses on the study of ozone, and its properties. Besides, it analyzes the therapeutic concepts of ozonotherapy. (3 credits)

MN013 - Iridology and Sclerology

This subject provides the naturopathic science student of the knowledge and skills necessary to perform health evaluation using iridology and sclerology.

Introduces students to the study of basic, intermediate and advanced concepts of iridology and sclerology as naturopathic methods of evaluation. (3 credits)

SN104- Bach Flowers

The subject of Bach Flowers deepens in the evaluation of the therapeutic effects of elixirs or essences extracted from flowers in the most common emotional disorders of the human being.

It includes knowledge about the floral therapies, its history and its mechanism of action, as well as the therapy of Dr. Edward Bach. (3 credits)

MN018 - Schüssler Salts

The course of **Schüssler Salts** analyzes 12 mineral salts that constitute the different body tissues and which lack can cause different clinical symptoms and pathologies.

Explains the origins of Schüssler Salts therapy, its functions and importance in the organism, its use to treat different common diseases and the correct form of prepare them and establishing the doses. (3 credits)

SN100 - Hydrology, Mineral-Medicine, Waters and Balneotherapy

This subject evaluates in depth one of the most common methods used since ancient times to prevent and treat diseases, through the therapeutic action of the water. This is achieved through the study of the history of this method, its therapeutic action, the water, the balneotherapy techniques, the thermalism and the mineral-medicinal waters. (3 credits)

SN093 - Pulsed Magnetic Wave and Hyperthermia

This subject discusses the curative application of electricity and magnetism, electrical properties of cells, electromagnetic fields, the water in the human body and main treatments.

Focuses on the study of electricity and magnetism, its curative effect and the main applications of Bioelectromagnetism in the treatment of diseases. (3 credits)

SN089 - Biological-Naturist Therapies for Common Diseases

This subject covers the evaluation of the biological-naturist therapies and its specific application in common diseases. (3 credits)

MN019- Supervised On-site Practices

This subject has the objective of complementing the knowledge acquired, favoring the practice of the skills in naturopathy that prepares students for the exercise of professional activities and promote their entrepreneurial capacity. This practice allows the student to promote a cooperative and collaborative work to respond in an open, critical and reflexive way that shows interaction between society, knowledge and technology; train them to function in a professional and/or scientific way autonomously, optimal and efficient; in addition students will develop the skills and attitudes needed to become professionals capable of providing health care that society demands today. (15 credits)

MN100- Master Final Project

This project allows students to write a n academic work that demonstrates the entire development of the project proposed. Must be a contribution to any of the fields studied or to their relationship, both theoretical and applied, and in accordance with the doctrines, theories and related disciplines.

The approval of the Master Final Project is individual. The student will demonstrate in this work maturity and capacity in front of a concrete problem in the health naturopathic medicine. The process to develop the Master Final Project follows a protocol that combines direct work with the Director of Thesis and sharing experiences through the media established for the Program in the Virtual Campus. (10 credits).

MTC025 - Hospital Stage

People's Republic of China Hospital Stage organized by the High School of MTC together with the European Foundation of MTC that complements the knowledge acquired, favoring the practice of the skills in Traditional Chinese Herbal medicine and acupuncture that prepares students for the exercise of professional activities and promote their entrepreneurial capacity.

This practice allows the student to promote a cooperative and collaborative work to respond in an open, critical and reflexive way that shows interaction between society, knowledge and technology; train them to function in a professional and/or scientific way autonomously, optimal and efficient; in addition students will develop the skills and attitudes needed to become professionals capable of providing health care that society demands today.

Students will be distributed in small groups to visit the departments of acupuncture, Tui Na and internal medicine departments of a hospital . China selected by the School of MTC together with the European Foundation of MTC In addition to the stage at the hospital, students will conduct follow-up activities related to Chinese medicine (specialized conferences, the practice of Tai Chi - Qi Gong and visits to museums). (10 credits).